



This is a digital copy of a book that was preserved for generations on library shelves before it was carefully scanned by Google as part of a project to make the world's books discoverable online.

It has survived long enough for the copyright to expire and the book to enter the public domain. A public domain book is one that was never subject to copyright or whose legal copyright term has expired. Whether a book is in the public domain may vary country to country. Public domain books are our gateways to the past, representing a wealth of history, culture and knowledge that's often difficult to discover.

Marks, notations and other marginalia present in the original volume will appear in this file - a reminder of this book's long journey from the publisher to a library and finally to you.

Usage guidelines

Google is proud to partner with libraries to digitize public domain materials and make them widely accessible. Public domain books belong to the public and we are merely their custodians. Nevertheless, this work is expensive, so in order to keep providing this resource, we have taken steps to prevent abuse by commercial parties, including placing technical restrictions on automated querying.

We also ask that you:

- + *Make non-commercial use of the files* We designed Google Book Search for use by individuals, and we request that you use these files for personal, non-commercial purposes.
- + *Refrain from automated querying* Do not send automated queries of any sort to Google's system: If you are conducting research on machine translation, optical character recognition or other areas where access to a large amount of text is helpful, please contact us. We encourage the use of public domain materials for these purposes and may be able to help.
- + *Maintain attribution* The Google "watermark" you see on each file is essential for informing people about this project and helping them find additional materials through Google Book Search. Please do not remove it.
- + *Keep it legal* Whatever your use, remember that you are responsible for ensuring that what you are doing is legal. Do not assume that just because we believe a book is in the public domain for users in the United States, that the work is also in the public domain for users in other countries. Whether a book is still in copyright varies from country to country, and we can't offer guidance on whether any specific use of any specific book is allowed. Please do not assume that a book's appearance in Google Book Search means it can be used in any manner anywhere in the world. Copyright infringement liability can be quite severe.

About Google Book Search

Google's mission is to organize the world's information and to make it universally accessible and useful. Google Book Search helps readers discover the world's books while helping authors and publishers reach new audiences. You can search through the full text of this book on the web at <http://books.google.com/>

TECHNICAL MANUAL

**LOGGING
AND
SAWMILL OPERATION**



HEADQUARTERS, DEPARTMENT OF THE ARMY

AUGUST 1972

University of Virginia Library
D 101.11:5-342/972
ADOC Logging and sawmill operation.

PX 001 695 657

89-80-P

ACKNOWLEDGMENTS

Acknowledgment is gratefully made to the organizations listed below for permitting us to use their copyrighted material in this manual.

Cascade Corporation
Figure 7-29.

Mar Hook and Equipment Incorporated
Figure 7-23.

S. Madill, Limited
Figure 7-28.

Western Conservation Journal
Figures 7-24, 7-25, 7-26, 7-27, and data on grapple yarding.

LOGGING AND SAWMILL OPERATION

	Paragraph	Page
LIST OF ILLUSTRATIONS -----	-----	ii
LIST OF TABLES -----	-----	iv
CHAPTER 1. INTRODUCTION -----	1-1, 1-2	1-1
2. TIMBER CRUISING -----	2-1-2-14	2-1
3. LOGGING CREW AND EQUIPMENT ----	3-1-3-5	3-1
4. LOGGING ROADS -----	4-1-4-4	4-1
5. FELLING -----	5-1-5-15	5-1
6. LIMBING, BUCKING, AND SCALING --	6-1-6-23	6-1
7. TRANSPORTING LOGS		
Section I. Skidding Logs With Choker Cables, Floating Logs, Moving Logs in Flumes and Chutes, and Loading Logs -----	7-1-7-14	7-1
Section II. Grappel Yarding -----	7-15-7-22	7-22
Section III. Balloon and Helicopter Logging -----	7-23-7-25	7-26
CHAPTER 8. SAWMILL EQUIPMENT		
Section I. Sawmill Components -----	8-1-8-14	8-1
Section II. Military Sawmills -----	8-15-8-17	8-14
CHAPTER 9. SAWMILL OPERATION		
Section I. Crew -----	9-1-9-3	9-1
Section II. Setting Up and Operating the Trailer-Mounted Sawmill -----	9-4-9-7	9-2
Section III. Sawing Procedures -----	9-8-9-16	9-4
Section IV. Safety -----	9-17-9-19	9-11
Section V. Operation of Civilian Sawmills by Engineering Units -----	9-20-9-23	9-18
Section VI. Operation Under Unusual Conditions -----	9-24-9-27	9-14
CHAPTER 10. CARE AND MAINTENANCE OF SAWS	10-1-10-7	10-1
11. LUMBERYARD OPERATIONS -----	11-1-11-16	11-1
APPENDIX A. REFERENCES -----	-----	A-1
B. METRIC SYSTEM		
Section I. Graphic Comparison of the Linear English and the Metric System -----	-----	B-1
Section II. Conversion Tables -----	-----	B-1
Section III. Conversion Factors -----	-----	B-3
GLOSSARY -----	-----	Glossary-1
INDEX -----	-----	Index-1

*This manual supersedes TM 5-342, 19 August 1966.

LIST OF ILLUSTRATIONS

Figure Number	Title	Paragraph	Page
2-1	The Abney hand level -----	2-3b	2-2
2-2	Percentage method of measuring tree heights -----	2-3d(3)	2-2
2-3	Construction of the modified Faustman hypsometer --	2-4a(1)	2-4
2-4	Modified Faustman hypsometer -----	2-4a(3)	2-5
2-5	Modified Merritt hypsometer -----	2-4b(1)	2-6
2-6	Use of steel tree tape -----	2-5b	2-7
2-7	Improvised calipers -----	2-6a(1)	2-8
2-8	Biltmore stick -----	2-6b(1)	2-9
2-9	Sample tally sheets -----	2-8a(1)	2-14
2-10	Plot method of estimating timber -----	2-13	2-17
2-11	Strip method of estimating a stand of timber -----	2-14	2-18
4-1	Lengthening a curve for tractor-arch logging -----	4-2c(6)	4-2
4-2	Layouts of skid trails -----	4-2c(7)	4-3
4-3	Skid road -----	4-3c	4-4
4-4	Truck road -----	4-3c	4-5
4-5	Development of switchbacks -----	4-3d	4-6
4-6	Location of water bars -----	4-3e	4-7
5-1	Felling patterns -----	5-3a	5-2
5-2	Clearing away small brush and saplings -----	5-5	5-3
5-3	The undercut -----	5-7a	5-4
5-4	Notching a large tree -----	5-7b	5-5
5-5	Testing direction of fall -----	5-8	5-5
5-6	How to make the backcut and hinge -----	5-9a	5-6
5-7	Normal felling cut -----	5-10b	5-6
5-8	Felling cut for large diameter tree -----	5-10c	5-6
5-9	Felling a leaning tree -----	5-11a	5-7
5-10	Pushing over a tree -----	5-11d	5-7
5-11	A "barber-chair" stump -----	5-11e	5-8
5-12	Methods used to prevent splitting of tree -----	5-11e	5-8
5-13	Felling rotten trees -----	5-12a	5-8
6-1	Safe position for limbing -----	6-2b	6-1
6-2	Cutting off a large limb -----	6-2c	6-2
6-3	Trimming -----	6-5a	6-3
6-4	A log measuring pole -----	6-5b	6-3
6-5	Log bucking plan -----	6-6	6-4
6-6	Method of propping and bucking a log -----	6-6h	6-5
6-7	Mechanical bucking chute -----	6-7	6-6
6-8	Sample form for a log scale book -----	6-9b	6-8
6-9	Examples of log rules -----	6-9d	6-9
6-10	Defects in logs -----	6-11b	6-10
7-1	Guards to protect the tractor operator -----	7-2a(2)	7-1
7-2	Chokers and choker hooks -----	7-3a(1)	7-2
7-3	Choker hook rigging -----	7-3b	7-2
7-4	Securing logs for ground skidding -----	7-4	7-3
7-5	Hitch for light logs and poles -----	7-4a	7-3
7-6	Ground skidding devices -----	7-5	7-4
7-7	Tractor and arch skidding -----	7-6a	7-6
7-8	Cable logging over a cliff -----	7-7a	7-7
7-9	Sky carriage and automatic hook -----	7-7b(2)	7-8
7-10	Skyline systems -----	7-7b(3)	7-8
7-11	The high-lead system and its use -----	7-7c	7-10
7-12	Two types of butt rigging for a high-lead -----	7-7c(2)	7-11
7-13	Use of the tight-lining system -----	7-7c(3)	7-11
7-14	A-frame rigging and guying -----	7-7d	7-12
7-15	Handling short bolts -----	7-8a(1)	7-13
7-16	Double-deck skidway -----	7-8b(1)	7-14
7-17	Cross-haul method of loading sawlogs -----	7-8b(2)	7-14
7-18	Permanent type loading devices -----	7-8b(3)(a)	7-15
7-19	Preloaders -----	7-8d(1)	7-15
7-20	Wet-storage facility -----	7-11c(1)	7-16
7-21	Jackladder -----	7-11c(3)	7-17

Figure Number	Title	Paragraph	Page
7-22	Chutes and flumes -----	7-12a(1)	7-18
7-23	The grapple -----	7-15	7-21
7-24	Logging grapple and carriage -----	7-15	7-21
7-25	Typical three-line running skyline rigged for grapple yarding -----	7-15	7-21
7-26	Grapple yarding with running skyline -----	7-15	7-22
7-27	Typical profile plot of a grapple yarding layout -----	7-17b	7-23
7-28	Yarding crane -----	7-19	7-24
7-29	Truck-mounted grapple -----	7-20	7-25
7-30	Fork and grapple attachment -----	7-21	7-26
8-1	Headsaw guide -----	8-3	8-1
8-2	Log-beam type carriage -----	8-5a	8-2
8-3	Headblock type sawmill -----	8-5b	8-3
8-4	Straight friction types of feed works -----	8-6a	8-4
8-5	Friction-belt-pulley feed works -----	8-6b	8-5
8-6	Belt-pulley feed works -----	8-6c	8-6
8-7	Belt-driven feed works with clutch -----	8-6d	8-6
8-8	Chain-driven feed works with level-controlled brake bevels on split housing -----	8-6e	8-6
8-9	Hydraulic feed works -----	8-6g(3)	8-6
8-10	Two-cylinder steam feed works -----	8-6h	8-7
8-11	Single-cylinder steam piston feed works -----	8-6h	8-7
8-12	Fixed-post types of manually operated dogs -----	8-8a	8-8
8-13	Housing-post types of manually operated dogs -----	8-8b	8-9
8-14	Hammer dog -----	8-8c	8-10
8-15	Boss dog -----	8-8d	8-10
8-16	Lever-actuated networks -----	8-9a	8-10
8-17	Spring-actuated receder -----	8-9b	8-11
8-18	Power receders -----	8-9c(1)	8-11
8-19	Power-actuated networks -----	8-9c(2)	8-11
8-20	Fixed-rope, friction-wheel type of power networks -----	8-9c(3)	8-12
8-21	Drum-actuated networks -----	8-9c(4)	8-12
8-22	Types of indicators -----	8-10	8-13
8-23	Indicator on bolster and knees -----	8-10	8-13
8-24	Single cutoff trim saw -----	8-14a	8-14
9-1	Sawing procedures -----	9-9d	9-5
9-2	Sawing oversized logs -----	9-13c(1)	9-9
10-1	Inserted saw teeth -----	10-2b(5)	10-3
10-2	Design of tooth and gullet, showing proper clearance and hook angles for solid-tooth saws -----	10-3c(1)	10-4
10-3	Method of measuring tension in a circular saw -----	10-4b	10-5
10-4	Trial mandrel -----	10-4c(1)	10-6
10-5	Equipment for tensioning saw -----	10-4c(1)	10-6
10-6	Alinement of saw -----	10-5b	10-9
10-7	Tooth holder and swages -----	10-5d	10-9
10-8	Tooth shaper and file frame -----	10-6c(3)	10-11
10-9	Tooth sharpening machine -----	10-6f(2)	10-11
10-10	Filing patterns and trimmer saw gage -----	10-6h(1)	10-12
11-1	A lumberyard layout -----	11-2b	11-1
11-2	Lumber props -----	11-3	11-2
11-3	End, rack, and crib piling methods -----	11-6b	11-4
11-4	Box piling -----	11-7	11-5
11-5	Sticker holder -----	11-12b	11-6
B-1	Comparison of the linear English and metric system	App B	B-1

LIST OF TABLES

Table Number	Title	Paragraph	Page
2-1	Location of Graduations on a Biltmore Stick Constructed for an Arm Reach of 25 Inches -----	2-6b(2)	2-9
2-2	Amount of Saw Timber in Hardwood Trees of Different Diameters and Merchantable Heights --	2-8b	2-12
2-3	Amount of Saw Timber in Softwood Trees (Pine, Spruce, etc.) of Different Diameters and Merchantable Heights -----	2-8b	2-13
2-4	Scribner Decimal C Log Rule -----	2-9c	2-15
4-1	Distance Between Water Bars -----	4-3e	4-5
6-1	Typical Log Grading System -----	6-4a	6-2
6-2	International Log Scale -----	6-23a	6-16
7-1	Safe Working Loads ¹ for Wire Rope (9 x 19 Plow Steel) on Horizontal Skylines (Based on Span of 1,000 Feet) ² -----	7-7b(5)	7-9
10-1	Interchangeability of Inserted Point on Teeth and Tooth Holders -----	10-2b(5)	10-2

CHAPTER 1

INTRODUCTION

1-1. Purpose and scope

a. This manual is a text and basic reference for all personnel engaged in logging or sawmill operations. It will serve as a guide for commanders of engineer forestry companies and teams as well as for subordinate supervisory and operating personnel.

b. This manual describes the procedures for estimating the volume of a given stand of timber, cutting the timber, removing it from the forest, moving it to the sawmill site, sawing it, and storing it in a lumberyard. The standard components of sawmills are described to aid engineer units in the operation of sawmills. The manual also discusses the duties of the operating personnel and the organization of crews, and prescribes safety measures.

c. The material presented herein is applicable without modification to both nuclear and nonnuclear warfare.

1-2. Comments

Users of this manual are encouraged to submit recommended changes to improve the manual. Comments should be keyed to the specific paragraph in which change is recommended. Reasons will be provided for each comment to insure complete evaluation. Comments should be prepared on DA Form 2028 (Recommended Changes to Publications) and forwarded directly to the Commandant, US Army Engineer School, Fort Belvoir, Virginia 22060.

CHAPTER 2

TIMBER CRUISING

2-1. Description

A timber cruise is a survey to determine the species, size, and density of standing timber in a given area. The cruiser either measures every tree in the stand or, more commonly, measures a sample of the given area and applies the data from the sample area to the entire stand. In the sample method, the larger the sample taken the greater will be the accuracy of the result. The trees are marked for cutting after the cruise is made. Tree volumes are usually calculated twice—after the cruise data have been collected the volume is estimated; then a more accurate measurement is made at the loading yard by a “log scaler.” Volumes are seldom computed during the actual cruise because of the need to use all available daylight for the cruise itself.

2-2. Timber Identification

This manual does not identify the types of timbers. The best method of determining timber types and their uses is to consult local users of timber. If these sources are unavailable, existing structures should be inspected and the timber used in their construction be compared to standing timber in the area.

2-3. Measurement of Height

a. Height To Which Tree Is Measured. Tree height measurement is taken to two different levels. One, usually required for growth studies, is to the very top of the tree. The other is to the top of the last usable log, normally where the tree is 6 inches to 8 inches in diameter. The latter is the height used by the cruiser in determining the number of logs in a tree. For simplicity in the following discussion, measurement of tree height will be taken to the top of the tree.

b. The Abney Level. The Abney topographic hand level (fig 2-1) is issued to the forestry teams for use in measuring the height of trees. This instrument has a reversible graduated arc (1) mounted on a level sighting tube. The level is

mounted perpendicular to the rotating index arm. Within the level sighting tube is a window for viewing the level.

c. Operation of the Hand Level. To measure height, sight through the eyepiece (6, fig 2-1) so that the crosswire intersects the tree at the desired point. Loosen the locking screw (9) and rotate the index arm (8) and level vial (3) until the crosswire bisects the bubble in the level. Tighten the locking screw and read result on the vertical arc (1). The result may be either slope percentage or slope angle depending on which side of the vertical arc is visible.

d. The Percentage Reading Method of Measuring Tree Height.

(1) The percentage method is the best method to use with the Abney hand level. It is fast, simple to calculate, and accurate enough for most timber cruising purposes. However, large vertical angles cannot be measured accurately because of the effect of refraction on observations of the level bubble through the tube from beneath.

(2) Set the vertical arc (1, fig 2-1) in position to indicate percentage of slope. If it is necessary to reverse the arc, unscrew the axis screw (2) holding the level vial (3) and index arm (8). Then remove the two arc attaching screws (7) and reverse the position of the arc. Reinstall the level vial and index arm with the axis screw. Tighten all screws.

(3) Take a position at any convenient point away from the tree. Measure the horizontal distance to the base of the tree. Determine the vertical angles from the horizontal to the tip of the tree (BAC, fig 2-2) and from the horizontal to the base of the tree (BAD, fig 2-2).

(4) Determine the total angle (CAD, fig 2-2) from the observer to the top and base of the tree and multiply this angle by the horizontal distance to the tree. Next point off two decimal places because the readings are in percentages. To determine the total angle, refer to figure 2-2.

(a) In case 1, $CAB + BAD = CAD$

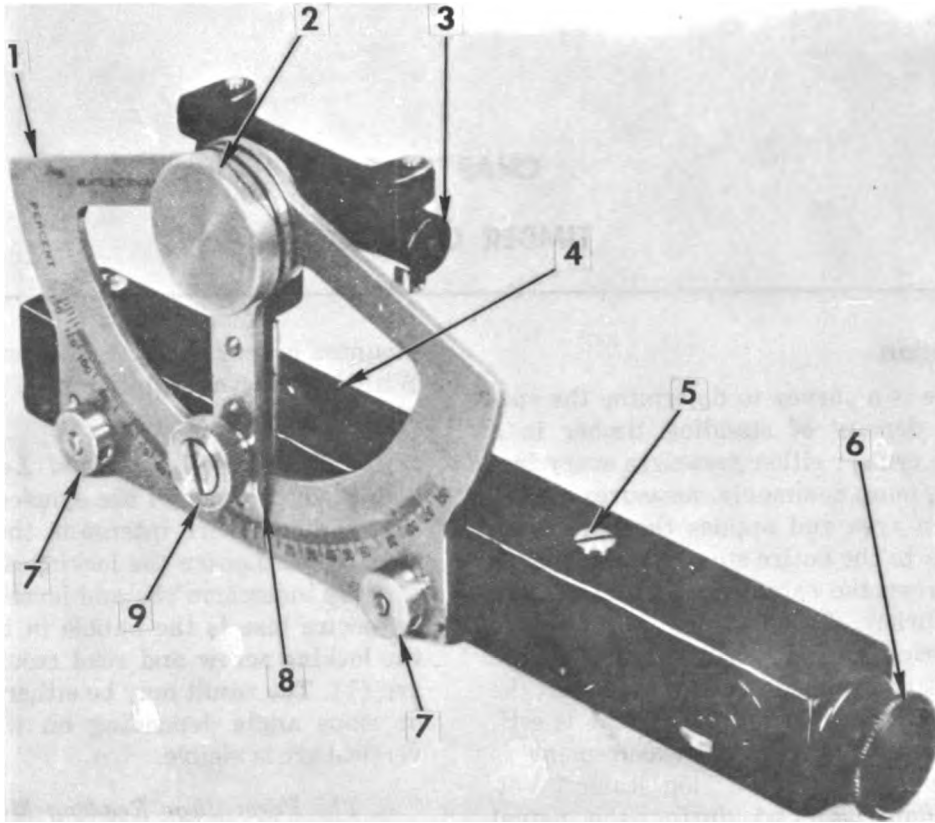

- | | | | |
|---|------------------------------|---|-----------------------|
| 1 | Vertical arc | 6 | Eyepiece |
| 2 | Arc and indicator axis screw | 7 | Arch attaching screws |
| 3 | Level vial | 8 | Index arm |
| 4 | Level viewing window | 9 | Locking screw |
| 5 | Level tube (box) | | |

Figure 2-1. The Abney hand level.

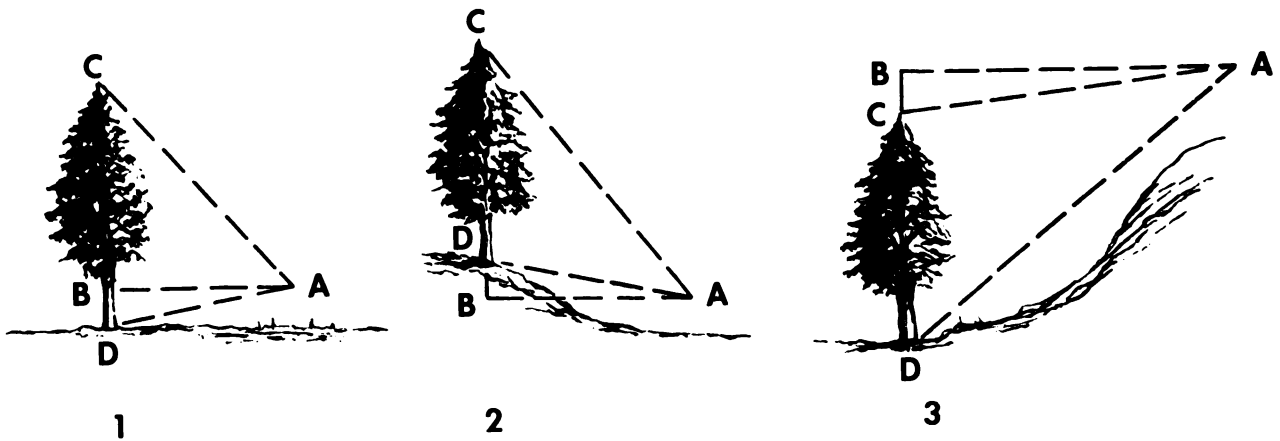

- 1 MEASURING FROM POINT ON LEVEL WITH BASE OF TREE
- 2 MEASURING FROM POINT BELOW BASE OF TREE
- 3 MEASURING FROM POINT ABOVE TOP OF TREE

Figure 2-2. Percentage method of measuring tree height.

(b) In case 2, $CAB - BAD = CAD$

(c) In case 3, $BAD - BAC = CAD$

(5) An example of this calculation is as follows:

(a) The distance AB(1) is 100 feet

(b) The angle BAC(1) is 30 percent

(c) The angle BAD(1) is 4 percent

(d) ADD: BAC 30 percent
 BAD 4 percent

—
Total 34

Multiply: AB(100 feet) times

$(BAC + BAD) = (34)$

$100 \times 34 = 34.00$

Therefore: The tree is 34 feet in height.

(6) Notice in the above calculation that if the angle readings are taken exactly 100 feet from the base of the tree, the calculation is reduced to a simple addition or subtraction of the two readings. Otherwise, a long multiplication problem results.

e. The Trigonometric Method of Measuring Tree Height.

(1) The trigonometric method of measuring tree height is slow and normally not practical for the military timber cruiser. However, in some instances, it may be the only practical method to use. For example, it may be practical in a dense forest containing many tall trees in which the timber cruiser may not be able to employ the percentage reading method or the cruiser's measuring stick.

(2) Set the vertical arc in position to read degrees of slope. Instructions for changing the scale are given in paragraph 2-3d(2).

(3) Take a position at any convenient point away from the tree. Measure the horizontal distance to the base of the tree. Determine the vertical angles from the horizontal to the top of the tree (BAC, fig 2-2) and from the horizontal to the base of the tree (BAD, fig 2-2).

(4) As illustrated in (1), figure 2-2:

$$\frac{BC}{BA} = \tan BAC$$

Hence,

$$BC = BA \tan BAC$$

Similarly,

$$BD = BA \tan BAD$$

The height of the tree is $BC + BD$ so that
Height = $BA(\tan BAC + \tan BAD)$

(5) The above calculation applies only if the position of the hand level is on an elevation between the base and the tip of the tree. If the situation shown in 2 or 3, figure 2-2 exists the following calculation will be used:

(a) The height is equal to either $BC - BD$ (2, fig 2-2) or $BD - BC$ (3, fig 2-2).

(b) If the height is $BC - BD$, then Height = $BA(\tan BAC - \tan BAD)$.

(c) If the height is $BD - BC$, then Height = $BA(\tan BAD - \tan BAC)$.

2-4. Improvised Height Measuring Instruments

The use of an improvised height measuring instrument for measuring tree heights may in certain cases be preferable to using the Abney level. Two height measuring instruments (hypsometers) that may easily be fabricated are the modified Faustman hypsometer and the modified Merritt hypsometer. Neither of the instruments is as accurate as the Abney level, but their use will greatly increase the speed of the timber cruising operation. With practice, the average timber cruiser can obtain a high degree of accuracy using the improvised instruments, but if there is a need for very exacting tree measurement, the cruiser should use the Abney level.

a. Modified Faustman Hypsometer.

(1) *Description.* As shown in figure 2-3, the modified Faustman hypsometer is of simple construction. It consists of a 7- by 9-inch board, a free swinging pendulum, a 50- to 100-foot horizontal distance scale, two sighting brads, and a handle. Each scale is calibrated for two types of measurements. The upper side of the scale is calibrated in feet with each quarter of an inch representing 4 feet. The lower side of the scale is calibrated in 16.3-foot lengths with each inch representing one 16.3-foot log. The upper scale is used when the observer is 50 feet from the base of the tree and the lower scale when he is 100 feet from the base of the tree.

(2) *Construction (fig 2-3).*

(a) Use a 1/2-inch board 7 by 9 inches and plane it smooth on all sides.

(b) Draw the line A-B three-eighths of an inch from the lower edge of the board and parallel to it.

(c) Two inches from the left end of the board draw a line C-D at right angles to line A-B.

(d) Make a mark at E, 6-1/4 inches from D, and another at F, 3-1/8 inches from D.

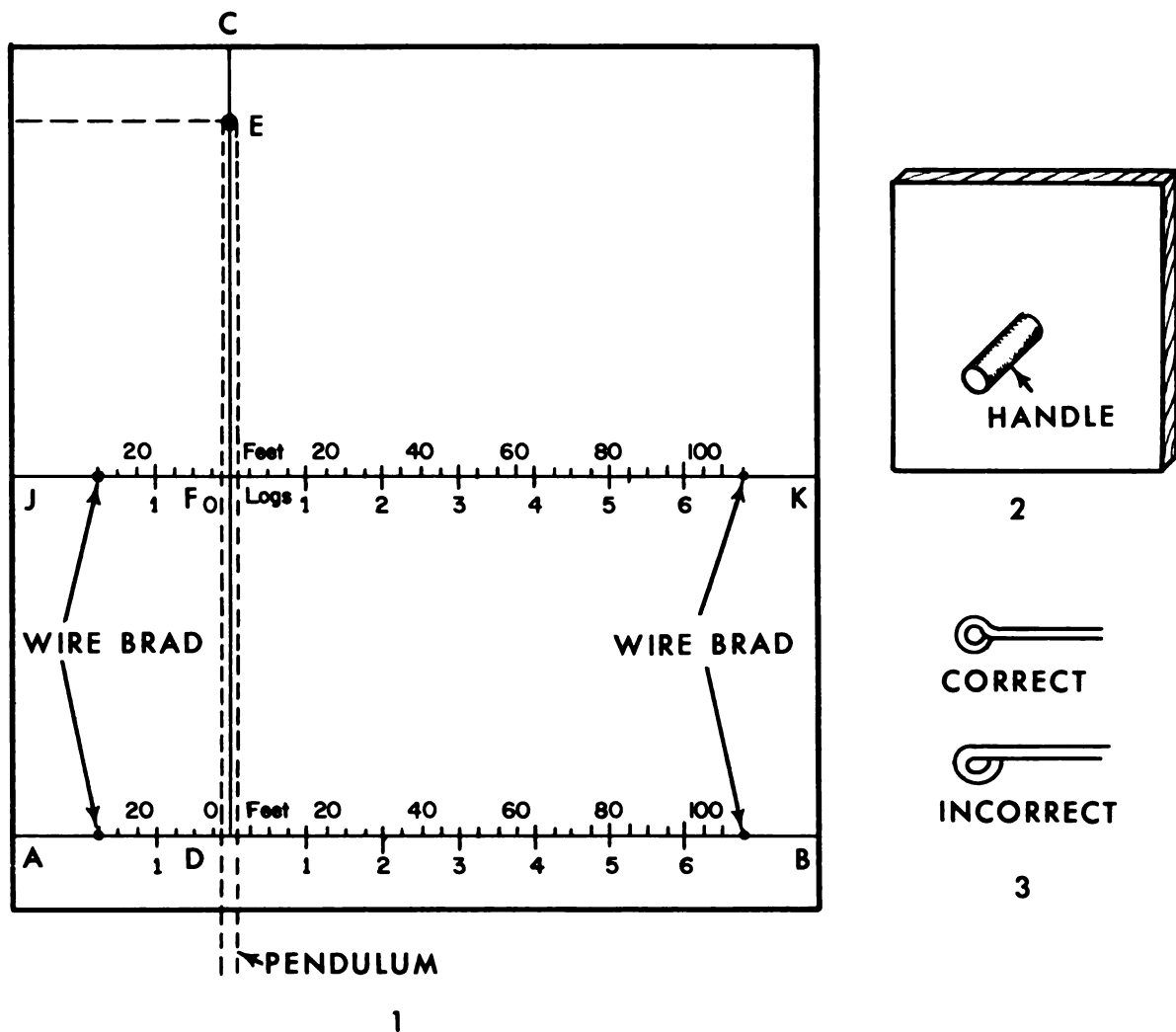

Figure 2-3. Construction of the modified Faustman hypsometer.

(e) Next, draw a line J-K through F parallel to line A-B.

(f) Starting at D, lay off inches and quarter inches on line A-B in both directions. Mark D as zero and, on the lower side of line A-B, put down the number of inches from D to each inch mark. Each inch mark on the scale represents one 16.3 foot log. The quarter inch graduations are equal to 4 linear feet.

(g) Do the same for line J-K.

(h) On the upper side of lines A-B and J-K put down the number of feet represented on the scale in 20-foot graduations.

(i) Use a brad or small nail and drive it in carefully on line J-K about 1 inch from the left edge of the board. Drive it in until the point comes out on the back of the board; then pull it out and drive it in from the back until the point sticks out about 1/4 inch from the face of the board. File or cut off any part of the brad that

projects from the back of the board. In the same way insert another brad near the opposite end of line J-K. Do the same on line A-B. These brads are the sights, it is important that they be straight and true.

(j) Use a piece of straight, heavy wire 10 inches long and bend one end of it into a loop about an eighth of an inch in diameter. The center of the loop should be in line with the straight part of the wire (3, fig 2-3).

(k) Use a 1/2 inch screw to attach the wire loosely at point E on line C-D. The loop must be big enough to fit loosely over the shank of the screw, but small enough so that it will not slip off over the head.

(l) Use a wood screw to attach a piece of wood about 6 inches long, 1 inch wide, and 1/2 inch thick or a round piece of wood approximately these dimensions, to the back of the board. This will serve as a handle (2).

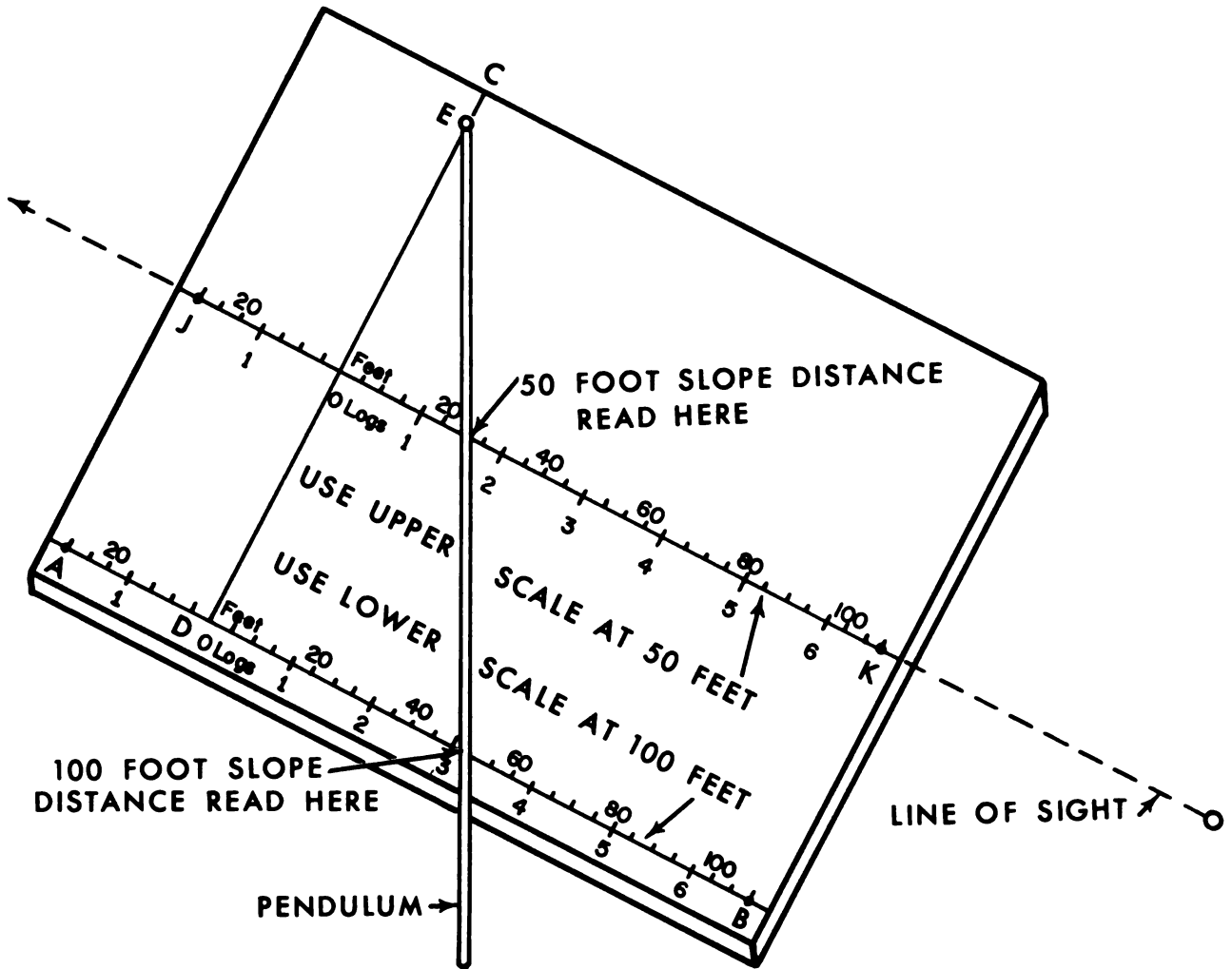

Figure 2-4. Modified Faustman hypsometer.

(3) Use (fig 2-4).

(a) To measure the total height of a tree, stand 100 feet from its base. Use the brads on the lower scale A-B for sighting, and make the readings on that scale. If the tree is less than 75 feet high, or if it is difficult to see the treetop at 100 feet, stand 50 feet from the base of the tree. In this case, use the brads on the upper scale J-K for sighting, and make the readings on that scale.

(b) Hold the instrument in the right hand so that the pendulum swings freely but very near the board.

(c) Sight along the brads at the uppermost point on the tree to be measured. When the sights are alined, let the pendulum come to rest on the board. When the instrument is sighted, the pendulum can be kept in position by tilting the hand slightly to the right, bringing the wire against the board and holding it in position so that the read-

ing can be obtained. Be careful that the wire does not move after the board is tilted.

(d) With the left hand, press the pendulum against the board without allowing it to move.

(e) Read the number of feet in height which the pendulum indicates on the appropriate scale.

(f) Next, sight at the foot of the tree and take another reading.

(g) If the pendulum hangs to the left of D, that is, between A and D, add the amount indicated to the first reading.

(h) If the eye level of the observer is below the base of the tree, the wire will hang to the right of D (between D and B). This being so, the amount of the second reading should be subtracted from the amount of the first. Thus, if the first reading is 96 feet and the second is 12 feet (to the right of D), the total height of the tree will be 96 less 12, or 84 feet.

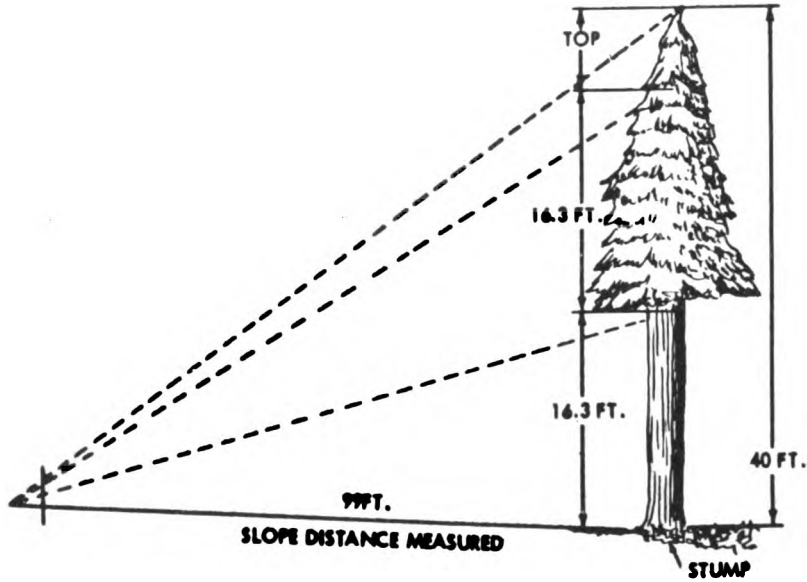

1

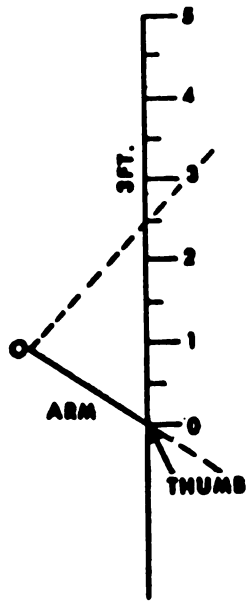

2

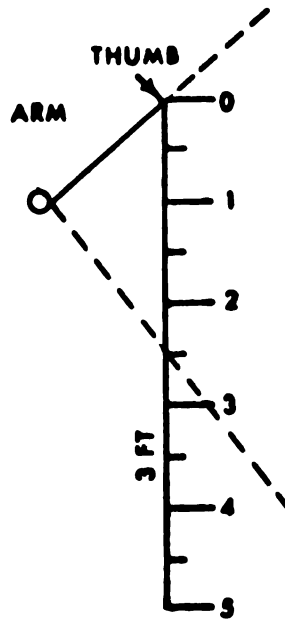

3

Figure 2-5. Modified Merritt hypsometer.

b. Modified Merritt Hypsometer.

(1) *Graduations.* The Merritt hypsometer (fig 2-5) is graduated for a fixed slope distance from the tree and a fixed arm reach. The usual graduations are 16.3-foot logs and 8.15-foot half logs, placed on a staff or on the back of a Biltmore stick (para 2-6b). The most frequent distances for which Merritt hypsometers are made are 1 chain (66 feet) or 1-1/2 chains (99 feet) (1, fig 2-5) for strip cruising, and 59 feet (the radius of

a 1/4 acre circular plot) for cruising by plots. Each cruiser should make his own Merritt hypsometer, since the distance between graduations would differ with the arm reaches of different men.

(2) *Lack of accuracy.* The Merritt hypsometer is not a precision instrument. The principal source of error is the probability that the observer will vary in the length of his arm reach. When a tree is extremely tall, the chance of error

is greatly increased by this variable arm reach factor. At best, the Merritt hypsometer can only be satisfactory for rough timber estimating.

(3) *Description.* The scale for the Merritt hypsometer is usually etched on a fairly hard wooden staff. The length of the staff is usually from 36 to 54 inches. The scale is placed on the staff above the halfway point so that when the staff is held lightly between the thumb and fingers (above the half-way point), the weight of the lower portion of the staff will aid in plumbing the stick. In some instances, the staff will have a weight imbedded in the lower portion to aid in plumbing the staff. Usually the scaling is etched on the opposite face of a Biltmore or similar diameter stick. The scale is placed on the stick in one of two ways—the graduations may run up the stick with zero at the lowest point on the scale (2, fig 2-5), or the graduations may run down the stick with zero at the highest point on the stick (3, fig 2-5). The placement of the scale depends on the preference of the user.

(4) *Computation of the scale.* Since each cruiser must make his own Merritt hypsometer, the following formula should be used in computing the scale:

(a) The graduating distance in inches equals the arm reach in inches times the height of one log in feet divided by the slope distance from the tree in feet.

(b) Assume that a Merritt hypsometer is made for a man whose arm reach is 25 inches, and is to be used by him at a distance of 1-1/2 chains from the tree and read in 16.3-foot log lengths. The distance between log length graduations then would be:

$$\frac{25 \times 16.3}{99} = 4.116 \text{ or } 4.1 \text{ inches apart.}$$

(5) *Use (fig 2-5).*

(a) From the tree, pace the slope distance for which the stick is graduated (99 feet is shown in fig 2-5).

(b) Hold the staff at arm's length and allow it to plumb itself by swinging freely between the thumb and forefinger. The position of the thumb and forefinger should be slightly below the zero mark. On the Merritt hypsometer in this example the scale is graduated from above the center to the top of the staff.

(c) When the staff is plumb, sight on the stump height and position the stick so that the zero mark intersects the line of sight to the tree.

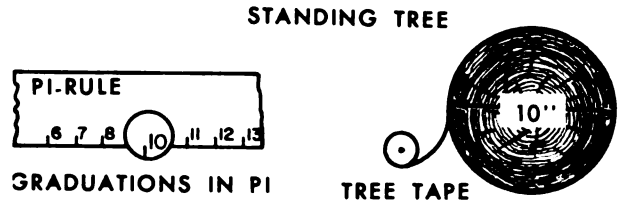

Figure 2-6. Use of steel tree tape.

Do not allow the stick or head to move after this sight is obtained.

(d) Moving only the eyes, sight along the scale to the highest point on the tree to be measured. The measurement is read where the line of sight to the high point on the tree intersects with the scale. Usually it is sufficient to obtain this measurement to the nearest half log or half foot.

2-5. Measurement of Diameter

a. Procedure.

(1) Diameter measurements for standing timber are made at breast height (4.5 feet) on the tree. This measurement is known as the diameter breast high (dbh) or diameter at breast height.

(2) If bark is included in the diameter measurement, the abbreviation dob (diameter outside bark) should be written after the measurement. In general practice, all tables are set up dob.

(3) In most cases it is necessary to measure only to the nearest inch. For example: a measurement of 6.4 inches is recorded as 6 inches, while one of 6.7 inches is entered as 7 inches.

b. *Steel Tree Tape.* The standard diameter-measuring instrument included in the supplementary equipment set is the steel tree tape. The tape (fig 2-6) is 20 feet long and has a different scale on each side. One side gives the circumference of the tree in feet and the other side of the tape gives the diameter of a tree in inches.

2-6. Improved Diameter-Measuring Instruments

Two types of instruments can be improvised in the field for estimating the diameter of standing trees. They are the tree calipers and the Biltmore stick.

a. Tree Calipers.

(1) *Description.* Improved tree calipers are a satisfactory substitute for manufactured tree calipers, and can be made easily and quickly. An ordinary carpenter's square forms the beam and fixed arm as shown in figure 2-7.

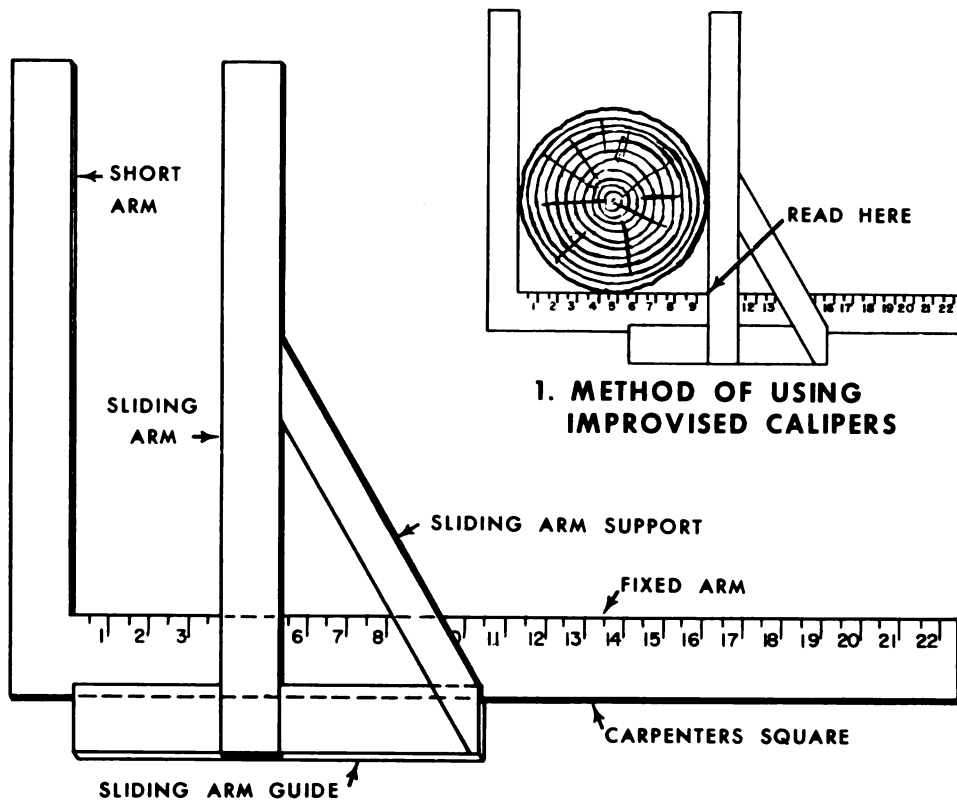

1. METHOD OF USING IMPROVISED CALIPERS

2. DETAILS OF IMPROVISED CALIPERS

Figure 2-7. Improvised calipers.

(2) Construction (2, fig 2-7).

(a) To construct the sliding arm, cut a strip of wood about 2 inches longer than the short arm of the square, 1-1/2 inches wide, and about 1/2 inch thick.

(b) For the sliding arm guide, cut a piece from a board having a groove along one edge. Flooring is good for this purpose.

(c) Screw or nail the sliding arm and the sliding arm guide together.

(d) Cut the sliding arm support to fit as shown in figure 2-7. Mortise the sliding arm guide and support so that they are flush with the square.

(e) Make sure that the sliding arm is exactly at right angles to the sliding arm guide before fastening the sliding arm support. This can be done by sliding the guide along the fixed arm until the inside face of the sliding arm is in contact with the short arm of the square. It may be necessary to lubricate the grooved portion of the guide to enable the sliding arm to move easily along the fixed arm.

(3) Use.

(a) To measure a tree, hold the instrument

horizontally at a height 4-1/2 feet above the ground (dbh) so that both the short and fixed arms are in contact with the bark.

(b) Slide the movable arm over until it touches the tree, being careful that the sliding arm guide stays in close contact with the fixed arm of the square.

(c) Read the diameter of the tree on the scale of the fixed arm (1).

(d) Handle the calipers carefully, since there is nothing mechanical to hold the sliding arm parallel and flush with the square. Take at least two readings and average these to compensate for error. Generally, the improvised calipers should be limited to trees up to 36 inches in diameter since anything larger would prove bulky and difficult to handle.

b. Biltmore Stick.

(1) Advantages and disadvantages. The Biltmore stick (fig 2-8) is much less accurate than calipers or the diameter tape. Its use is ordinarily confined to cruising in which most of the diameter measurements are estimated. In this case, the instrument is used as a check on eye estimates. Two advantages of the Biltmore stick are—it is faster

than the diameter tape and much easier to carry and handle than either the calipers or the diameter tape, and the scale of the Biltmore stick may be etched on the opposite face of the Merritt hypsometer.

(2) *Description.* The Biltmore stick is a ruler graduated in such a way (table 2-1) that when it is held at arm's length tangent to the tree, the diameter of the tree can be read directly on the scale. Usually the scale does not exceed 24 inches in length. The top half of the face of the rule is beveled so that the graduations approach the back; otherwise, the thickness of the stick becomes a factor and must be subtracted from the arm reach. Since the graduations on the scale are in direct relation to the arm reach of the user, the following formula is used to compute the scale:

$$G = \sqrt{\frac{aD^2}{a + D}}$$

where, G is the distance from zero on the Biltmore stick to any graduation corresponding to the dbh of any tree.

D is the dbh of any tree.

a is the length of arm for which the stick is calibrated.

For example (fig 2-8), assume the graduation for a tree 17 inches dbh is desired for a cruiser with an arm reach of 25 inches:

$$a = 25 \text{ inches}$$

$$D = 17 \text{ inches}$$

Substituting these values:

$$G = \sqrt{\frac{25 \times 17^2}{25 + 17}}$$

$$= 172.024 = 13.12 \text{ inches}$$

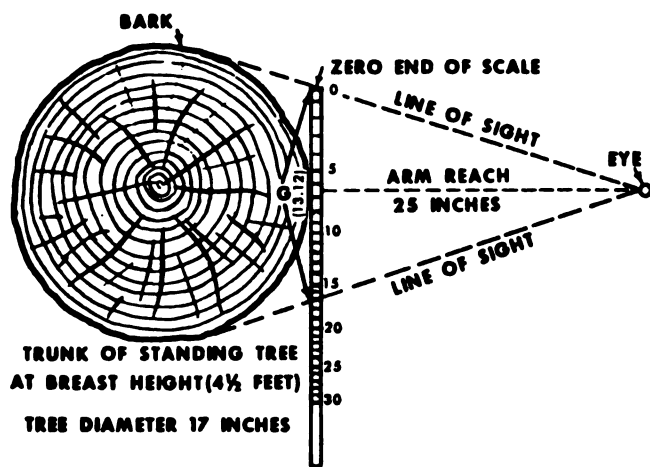

Figure 2-8. Biltmore stick.

Therefore, the graduation mark for a 17-inch diameter tree would be located 13.12 inches from the zero mark on the scale.

Table 2-1. Location of Graduations on a Biltmore Stick Constructed for an Arm Reach of 25 Inches

Graduation for following dbh—(inches)	Distance from 0 to graduation (inches)
1	0.98
2	1.92
3	2.83
4	3.72
5	4.56
6	5.40
7	6.19
8	6.97
9	7.73
10	8.45
11	9.17
12	9.87
13	10.55
14	11.22
15	11.87
16	12.50
17	13.12
18	13.72
19	14.32
20	14.91
21	15.48
22	16.04
23	16.60
24	17.14
25	17.68
26	18.20
27	18.72
28	19.23
29	19.73
30	20.23
31	20.72
32	21.19
33	21.66
34	22.13
35	22.59
36	23.05
37	23.49
38	23.98
39	24.37
40	24.81
41	25.25
42	25.67
43	26.09
44	26.49
45	26.89
46	27.29
47	27.69
48	28.09
49	28.48
50	28.87

Table 2-1. Location of Graduations on a Biltmore Stick Constructed for an Arm Reach of 25 Inches—Cont.

Graduation for following dbh—(inches)	Distance from 0 to graduation (inches)
51	29.25
52	29.63
53	30.01
54	30.38
55	30.75
56	31.11
57	31.47
58	31.83
59	32.19
60	32.54

(3) *Length of stick and graduation.* In practice, each cruiser graduates his own Biltmore stick according to his own arm reach. Normally, the stick should be no longer than 24 inches. For the average cruiser this will take care of trees up to 36 inches. A longer stick is more difficult to control and there is a tendency to get it out of perpendicular either with the arm or with the tree.

(4) *Use of stick.*

(a) Estimate the diameter of the tree as you approach it, and then place the thumb on the graduation corresponding to half this diameter and the second and third fingers on the lower half of the back of the stick behind this point.

(b) Step up to the tree to determine the breast high point, tilt the beveled top edge of the stick against the trunk of the tree at this point, and step back until the tree is at arm's reach.

(c) Line up the stick at right angles to the trunk of the tree and at right angles to your arm, and check to see that your eyes are on a level with your thumb. Your body may have to be raised or lowered, but do not incline your head.

(d) Inch the stick along your fingers until you sight the zero point between your eye and the left side of the tree.

(e) Sight over the stick to the right side of the tree and determine the graduation this line of sight intersects. This is the diameter of the tree.

(5) *Limited accuracy.* The use of the Biltmore stick should be limited to cases where great accuracy is not required and where only enough trees are being measured to check the accuracy of estimate by eye. Properly used, it is a convenient and satisfactory instrument.

(6) *Difficulty in rough terrain.* The Biltmore stick produces less satisfactory results in steep,

rough country than in flat country because of the difficulties involved in leveling the eye with the stick.

2-7. Comparison of Three Common DBH Measuring Instruments

a. *Accuracy.* Assuming each instrument is used correctly, both calipers and diameter tape are accurate enough to be classed together for practical purposes, while the Biltmore stick must be rated the least accurate of the three instruments for finding the dbh of a number of trees. Calipers are most accurate only if applied to true average diameter. Trees frequently are not cylindrical; therefore, an estimate must be made of where to apply calipers, or else several measurements must be taken. The diameter tape is the most consistent of the three instruments.

b. *Rapidity.* The dbh of any tree can be measured most rapidly with calipers, less rapidly with the Biltmore stick, and least rapidly with the diameter tape.

c. *Ease of Handling.* The tape is the most easily carried about; but since it must be unwound and wound up again at each tree, the tape is more practical where it is used only as a check and an occasional tree is measured. The Biltmore stick is only slightly more difficult to carry about and does not require preparation for use at each tree. The calipers are the most cumbersome of the three to carry around. When the instruments are used merely for checking, therefore, the Biltmore stick is the most easily handled, the tape is next, and the calipers are last. Where every tree is measured, the calipers are more easily handled and the tape is next; the Biltmore stick would not be used because of its lower accuracy.

d. *Use.*

(1) For rapid timber cruising where the diameters are estimated by eye, the diameters can be checked with the Biltmore stick most advantageously unless the country is so rough that a tape is necessary.

(2) For more accurate cruising, where every tree on strips or plots is measured, calipers would ordinarily be used, except for large timber. In this case, a choice would be made between using a diameter tape, or making two measurements on each tree at right angles to each other with the Biltmore stick. Where small and large timber occur in the same area, calipers are sometimes used for trees up to 36 inches and the diameter tape on all larger trees.

(3) For permanent sample plot work, where the same trees are to be measured at different periods and by different men and where consistent results are essential, the diameter tape should always be used.

2-8. Volume Table

The volume table is the best standard of measurement for estimating the volume of standing trees.

a. Description. A volume table gives the average number of board feet which a tree of a given size is estimated to contain. The size of a tree is considered to be its diameter breast high, measured in inches, and its usable height (or length), measured in number of 16-foot logs. A volume table is developed by scaling a number of trees and determining the average number of board feet in the trees for each size measured. Trees differ in shape and usable wood content but if a large enough sample is measured the averages are accurate.

b. Use of Tables for Different Trees. Since different kinds of trees differ from each other in form, the volume table made for one species does not necessarily apply accurately to another. There is not as much difference between the individual hardwoods and softwoods. Table 2-2 can be used as a general volume table for hardwoods (broad-leaf) and table 2-3 for softwoods (conifers). Certain factors are given by which correction can be made so as to produce accurate results for different kinds of trees. For example, the hardwoods table applies to red oak without correction, but for white oak 10 percent must be added when the trees are from 18 to 40 inches in diameter.

c. Measurements Used. The standard unit of volume measurement for logs in the United States is the board foot (section 12 by 12 inches by 1 inch thick, or its equivalent); however, the timber cruiser should be prepared to take measurements and make computations in the standard of measure for the country or area in which he is located. Appendix B contains a conversion table for most of the units of measure employed for timber and lumber.

d. Estimating With Volume Tables.

(1) Volume tables are made to show the volumes of trees based on the diameters and number of logs in the trees. A tally sheet must, therefore, be prepared in these same units. A sample tally sheet is shown in 1, figure 2-9. The symbols used in tallying are shown at the bottom of the sample sheet. The dot method is the preferred method.

(2) The first 16-inch, 2-log tree would be tallied by putting a dot in the upper left-hand corner of the square opposite 16 inches and in the column headed 2-log, under the type of tree being tallied. The second 16-inch, 2-log tree would be tallied by placing a dot in the upper right-hand corner of the same square; and so on. A new tally sheet is used after 10 have been tallied.

(3) When all the trees have been tallied, the estimator multiplies the total number of each size tree by the number of board feet in that tree. For example, suppose that there are twelve 3-log white oaks 18 inches in diameter. The volume table indicates that the trees of this size contain 260 board feet, plus a correction factor of 10 percent (table 2-2). The 286 is multiplied by 12. The same thing is done for each of the other white oak sizes (table 2-2) and the results are totaled. This gives the total number of board feet of white oak. The same procedure is followed to obtain the number of board feet of each species tallied.

2-9. Estimating Without Volume Tables

Where no volume table is available it is possible to estimate standing timber fairly accurately by measuring the diameter and length of the tree and using the Scribner decimal C log rule.

a. A notebook or sheet of paper can be ruled off in squares of a convenient size somewhat as shown in 2, figure 2-9.

b. The estimator looks over the first tree and makes an estimate of the number of logs that can be cut out of it. Suppose the first tree is a white oak which forks about 50 feet from the ground. Above that point the branches are too small or too crooked to be used for saw logs. Allowing for the stump, the usable length of the tree is 48 feet, or three 16-foot logs. By looking at the tree carefully the estimator decides that the diameter, inside the bark, at the top of the first 16-foot log is 16 inches. Sixteen feet farther up, the diameter appears to be 2 inches less, while at the top of the third log the diameter is 11 inches.

c. These figures are entered in the proper spaces as shown in 2, figure 2-9. Later on, the number of board feet in each of the three logs can be determined with the Scribner decimal C log rule (table 2-4), and the total board foot content of the tree found by adding the results. The log rule presented in table 2-4 gives the board foot content in tens, that is—6 in the table indicates 60, 7 indicates 70, 0.5 indicates 5, and so on. (Use of the Scribner C rule for its primary purpose of scaling logs is described in paragraph 6-10.)

Table 2-2. Amount of Saw Timber in Hardwood Trees of Different Diameters and Merchantable Heights

Diameter of tree, breast high (inches)	Number of 16-foot logs									Diameter of top (inside bark) (inches)	Basis for this table (trees)
	1	1½	2	2½	3	3½	4	4½	5		
	Volume* in board feet										
8	20	27	35	43						6	
9	20	32	42	53						6	1
10	20	36	52	64	81					6	2
11	21	43	62	78	98	120				6	4
12	23	50	73	93	120	140	180			6	3
13	25	58	86	110	140	170	200			7	4
14	27	67	100	130	160	190	230	260		7	9
15	30	77	120	150	180	220	260	300		8	15
16	34	89	130	170	200	250	290	340	390	8	18
17	38	100	150	190	230	280	320	380	440	9	40
18	43	120	170	210	260	310	360	420	490	9	56
19	48	130	200	240	290	350	400	470	540	10	65
20	54	150	220	270	330	390	450	520	590	10	75
21	62	170	250	300	370	440	500	508	650	11	86
22	69	190	270	340	410	480	550	640	720	11	90
23	77	210	300	380	450	530	610	700	790	12	67
24	85	230	340	420	500	580	670	770	860	12	80
25	93	250	370	460	550	640	740	840	940	13	56
26	100	280	410	510	600	700	810	910	1,020	13	89
27	110	300	450	560	660	770	880	990	1,110	14	68
28	120	330	490	610	720	830	960	1,080	1,200	14	81
29	130	360	530	660	780	900	1,030	1,160	1,300	15	61
30	140	390	580	720	850	980	1,120	1,250	1,400	15	47
31		420	630	770	910	1,050	1,200	1,350	1,510	16	45
32		450	690	830	980	1,130	1,290	1,450	1,620	16	40
33		480	740	890	1,050	1,211	1,380	1,560	1,730	17	49
34			800	950	1,120	1,290	1,480	1,670	1,860	17	30
35			860	1,010	1,180	1,380	1,570	1,790	1,990	18	22
36			920	1,070	1,250	1,460	1,680	1,910	2,140	18	17
37				1,130	1,320	1,550	1,780	2,040	2,290	19	24
38				1,190	1,390	1,640	1,890	2,170	2,450	19	11
39				1,250	1,460	1,730	2,000	2,300	2,600	20	16
40				1,310	1,540	1,820	2,120	2,430	2,760	20	15
41					1,610	1,910	2,240	2,570	2,980	21	6
42					1,680	2,000	2,360	2,720	3,100	21	3
43					1,750	2,090	2,470	2,860	3,270	22	3
44					1,830	2,180	2,590	3,010	3,450	22	2
											1,300

*Volumes of trees as sawed out in average practice.
 Correction factors for different species.
 Chestnut, for diameters from 8 to 40 inches, subtract 10 percent.
 Chestnut oak, for diameters from 32 to 40 inches, add 10 percent.
 White oak, for diameters from 18 to 40 inches, add 10 percent.
 Other common hardwoods, for all diameters, use the table without change.

Table 2-3. Amount of Saw Timber in Softwood Trees (Pines, Spruce, etc.) of Different Diameters and Merchantable Heights

Diameter of tree, breast high (inches)	Number of 16-foot logs						Basis for this table (trees)	
	1	2½	3	3½	4	4½		5
	Volume* (board feet)							
8	37	52	66	75	84		12	
9	41	58	70	82	93		9	
10	47	66	77	92	100	120	12	
11	53	74	86	100	120	140	13	
12	60	83	97	120	140	160	200	8
13	68	94	110	130	160	190	220	4
14	77	110	120	150	180	210	240	7
15		120	140	170	200	240	270	11
16		130	160	190	230	270	310	20
17		150	180	220	260	300	340	21
18		170	210	250	280	330	380	20
19		190	230	280	320	370	420	34
20		210	260	310	360	410	470	27
21			290	350	400	460	520	38
22			320	390	440	510	570	40
23			360	430	490	560	620	37
24			400	470	540	620	680	37
25			440	520	600	680	740	47
26			480	560	660	740	810	52
27				600	720	800	880	43
28				650	780	870	950	45
29					840	940	1,030	39
30					910	1,010	1,100	47
31						1,080	1,180	40
32						1,150	1,260	44
33						1,230	1,340	39
34							1,420	36
35							1,500	34
36							1,580	29

*Volumes of trees as sawed out in average practice.
 Correction factors for different species.
Hemlock:
 For diameters from 8 to 10 inches, add 10 percent.
 For diameters from 11 to 20 inches, add 22 percent.
 For diameters from 21 inches and up, add 29 percent.
Red spruce:
 For diameters from 8 to 10 inches, add 5 percent.
 For diameters from 11 inches and up, add 25 percent.
Short leaf pine:
 For diameters from 10 inches and under, add 15 percent.
 For diameters from 11 to 19 inches, add 25 percent.
 For diameters from 20 to 23 inches, add 25 percent.
 For diameters from 24 inches and over, add 40 percent.
 White pine and other common conifers, for all diameters, use the table without change.

PLOT NO

DIAMETER OF TREE BREAST-HIGH (INCHES)	WHITE OAK			BLACK OAK			TULIP POPLAR			HICKORY			CHESTNUT			ETC.		
	1-LOG	2-LOG	3-LOG	1-LOG	2-LOG	3-LOG	1-LOG	2-LOG	3-LOG	1-LOG	2-LOG	3-LOG	1-LOG	2-LOG	3-LOG	1-LOG	2-LOG	3-LOG
8																		
10																		
12																		
14																		
16																		
18																		
20																		



1. SHEET WITH TALLYING SYMBOLS FOR USE WHEN VOLUME TABLES ARE AVAILABLE

SPECIES	BUTT LOG			SECOND LOG			THIRD LOG			TOTAL SCALE
	LEN	DIA	SCALE	LEN	DIA	SCALE	LEN	DIA	SCALE	
	FEET	INCHES	BD. FT.	FEET	INCHES	BD. FT.	FEET	INCHES	BD. FT.	BD. FT.
WHITE OAK	16	16		16	14		16	11		
RED OAK	12	10		12	8					
SUGAR MAPLE	14	15		12	12					
BEECH	16	18		16	16		14	13		
(ETC.)										

2

2. SHEET FOR TALLYING WHEN VOLUME TABLES ARE NOT AVAILABLE

Figure 2-9. Sample tally sheets.

Table 2-4. Scribner Decimal C Log Rule

Diameter (inches)	Length (feet)											Diameter (inches)
	6	7	8	9	10	11	12	13	14	15	16	
	Contents (bd ft) in tens											
6	0.5	0.5	0.5	0.5	1	1	1	1	1	1	2	6
7	0.5	1	1	1	1	2	2	2	2	2	3	7
8	1	1	1	1	2	2	2	2	2	2	3	8
9	1	2	2	2	3	3	3	3	3	3	4	9
10	2	2	3	3	3	3	3	4	4	5	6	10
11	2	2	3	3	4	4	4	5	5	6	7	11
12	3	3	4	4	5	5	6	6	7	7	8	12
13	4	4	5	5	6	7	7	8	8	9	10	13
14	4	5	6	6	7	8	9	9	10	11	11	14
15	5	6	7	8	9	10	11	12	12	13	14	15
16	6	7	8	9	10	11	12	13	14	15	16	16
17	7	8	9	10	12	13	14	15	16	17	18	17
18	8	9	11	12	13	15	16	17	19	20	21	18
19	9	10	12	13	15	16	18	19	21	22	24	19
20	11	12	14	16	17	19	21	23	24	26	28	20
21	12	13	15	17	19	21	23	25	27	28	30	21
22	13	15	17	19	21	23	25	27	29	31	33	22
23	14	16	19	21	23	26	28	31	33	35	38	23
24	15	18	21	23	25	28	30	33	35	38	40	24
25	17	20	23	26	29	31	34	37	40	43	46	25
26	19	22	25	28	31	34	37	41	44	47	50	26
27	21	24	27	31	34	38	41	44	48	51	55	27
28	22	25	29	33	36	40	44	47	51	54	58	28
29	23	27	31	35	38	42	46	49	53	57	61	29
30	25	29	33	37	41	45	49	53	57	62	66	30
31	27	31	36	40	44	49	53	58	62	67	71	31
32	28	32	37	41	46	51	55	60	64	69	74	32
33	29	34	39	44	49	54	59	64	69	73	78	33
34	30	35	40	45	50	55	60	65	70	75	80	34
35	33	38	44	49	55	60	66	71	77	82	88	35
36	35	40	46	52	58	63	69	75	81	86	92	36
37	39	45	51	58	64	71	77	84	90	96	103	37
38	40	47	54	60	67	73	80	87	93	100	107	38
39	42	49	56	63	70	77	84	91	98	105	112	39
40	45	53	60	68	75	83	90	98	105	113	120	40
41	48	56	64	72	79	87	95	103	111	119	127	41
42	50	59	67	76	84	92	101	109	107	126	134	42
43	52	61	70	79	87	96	105	113	122	131	140	43
44	56	65	74	83	93	102	111	120	129	139	148	44
45	57	66	76	85	95	104	114	123	133	143	152	45
46	59	69	79	89	99	109	119	129	139	149	159	46
47	62	72	83	93	104	114	124	134	145	155	166	47
48	65	76	86	97	108	119	130	140	151	162	173	48
49	67	79	90	101	112	124	135	146	157	168	180	49
50	70	82	94	105	117	129	140	162	164	175	187	50

d. In some cases it may be desirable to indicate the grade of each log in the tree. The butt logs next to the stump are generally of the highest grade and the top logs are the lowest. Where there is more demand for No. 1 logs, the difference may be enough to make it worthwhile to separate them from the No. 2 or No. 3 logs. Log grading is discussed in paragraph 6-4.

e. The grade of the logs can be indicated in the upper right-hand corner of the square which is left for the board-foot contents of the log. When the final figures are added up, only those which have a "1" in the upper right-hand corner will be added together to get the total amount of No. 1 logs; then the values of No. 2 are added, and so on.

2-10. Estimating Volume of a Stand of Timber

a. The skills and tools necessary to complete a timber cruise have been discussed in the preceding paragraphs. The next step is to apply these skills and tools in estimating the volume of the stand of timber. There are two types of estimates—the total estimate and the partial estimate. The estimate is called a total estimate if the size of every tree in the stand is recorded. It is called a partial estimate if the sizes of only a part of the trees, distributed over the whole stand or grouped in plots or strips, are recorded.

b. The information desired from a timber cruise is essentially, as stated above, an estimate of the volume of timber on a specific tract. However, the completed timber cruise must also include a map of the tract showing the location of roads, trails, buildings, lakes, streams, fences, boundary lines, telephone and transmission lines, contours, and so on. All of this information is valuable in planning the logging operation.

2-11. Total Estimate

a. *Accuracy.* The principal task in obtaining the total estimate is the accurate recording of the measurement of every tree or log in a stand. Trees are marked with chalk, keel (colored marking crayon), paint, whitewash, or a scribe, or with a small blaze, to avoid recording the same tree or log twice and also to avoid missing any tree or log.

b. *Boundaries.* The boundaries of the tract should be clearly marked so that all trees inside the boundaries will be included in the record and all those outside the boundaries will be excluded.

c. *Cruising Plan.* In order to record each tree just once and not miss any, it is desirable to divide the tract into strips of convenient width. Since all trees are to be measured, the width of each strip need not be uniform. Strips passing through dense parts of the stand may be narrow, while those through open portions may be wider.

d. *One-Man Cruising.* If one man is doing the estimating, he should mark every tree as he records it. This avoids duplication or omission. He should put all the marks on the same side so he can see them without going around each tree. He need not mark his strips on the ground since the marks on the tree will guide him away from those already recorded.

Warning: The practice of sending one man into a forest is not recommended. If the man is seriously hurt, he might remain indefinitely without aid.

e. *Crew Cruising.*

(1) *Two men.* When two men work together, the recorder (notekeeper) walks along the outside edge of the strip and scuffs a line in the litter or marks the trees. He keeps himself lined up with the cruiser and watches carefully to see that the cruiser calls out all the trees and does not call out the same tree twice. The cruiser walks back and forth between the marked boundary of the previous strip and the boundary which the recorder is marking and measures all the trees as he goes, calling the measurement of each tree.

(2) *Three men.* When the cruising party consists of three men, there are two cruisers and one recorder. The recorder walks between the two cruisers and each cruiser marks his tree as he calls it out to the recorder.

(3) *Four men.* Where there are four men in the crew, one serves as a recorder and the other three estimate. The recorder walks down the middle of the strip in the middle cruiser's area. Each cruiser marks his tree as he calls it out to the recorder. A crew larger than four men is impractical because the recorder cannot keep up with the estimators.

2-12. Partial Estimate

a. *Use of Samples.* In cruising large areas of timber, it is impractical to measure the diameter and height of every tree in the stand. The customary procedure is to make a total estimate of several sample areas in the forest. The entire stand volume is determined by multiplying the sample volume by the ratio of the entire stand area to the

sample area. In making partial timber estimates, two general methods of taking the samples are used—the sample plot method, and the parallel strip method.

b. Sampling.

(1) When partial estimates are made, great care must be taken to see that they are truly representative of the whole tract being sampled and that the relationship between the area of the sample and the area of the whole tract is known accurately. The method of sampling should be mechanical, and the samples should be distributed over as much of the tract as possible.

(2) The size of the sample taken in a partial estimate depends upon the variation in size and species of the trees in the area. A larger sample must be taken for areas where the trees vary greatly in species and size than for areas which are uniform in both size and distribution of trees.

c. Classification of Forest Stands and Types.

(1) *Stands.* A stand is a group of trees, uniform in composition and condition, standing on a limited area. The composition refers to the princi-

pal species of which the stand is composed; the condition refers to the origin, age distribution, and development of the stand. Generally, the limited stand should not exceed 200 acres in area.

(2) *Forest type.* A forest type is a group of stands which are similar in composition and development due to given physical and biological factors. There are a number of different type classifications but the grouping most frequently used in timber estimating is that of cover types which are based on the vegetation of the specific area. For example, in a group of hard pine, red oak, yellow poplar, and maple, each of these cover types would ordinarily grade into its neighboring cover type in a transitional band. The cruiser must accept the center of this transitional band as the boundary between the two adjacent cover types.

2-13. Partial Estimates by the Sample Plot Method

The sample plot method (fig 2-10) of obtaining a partial estimate is the simplest method of obtaining a sample from a limited stand of timber.

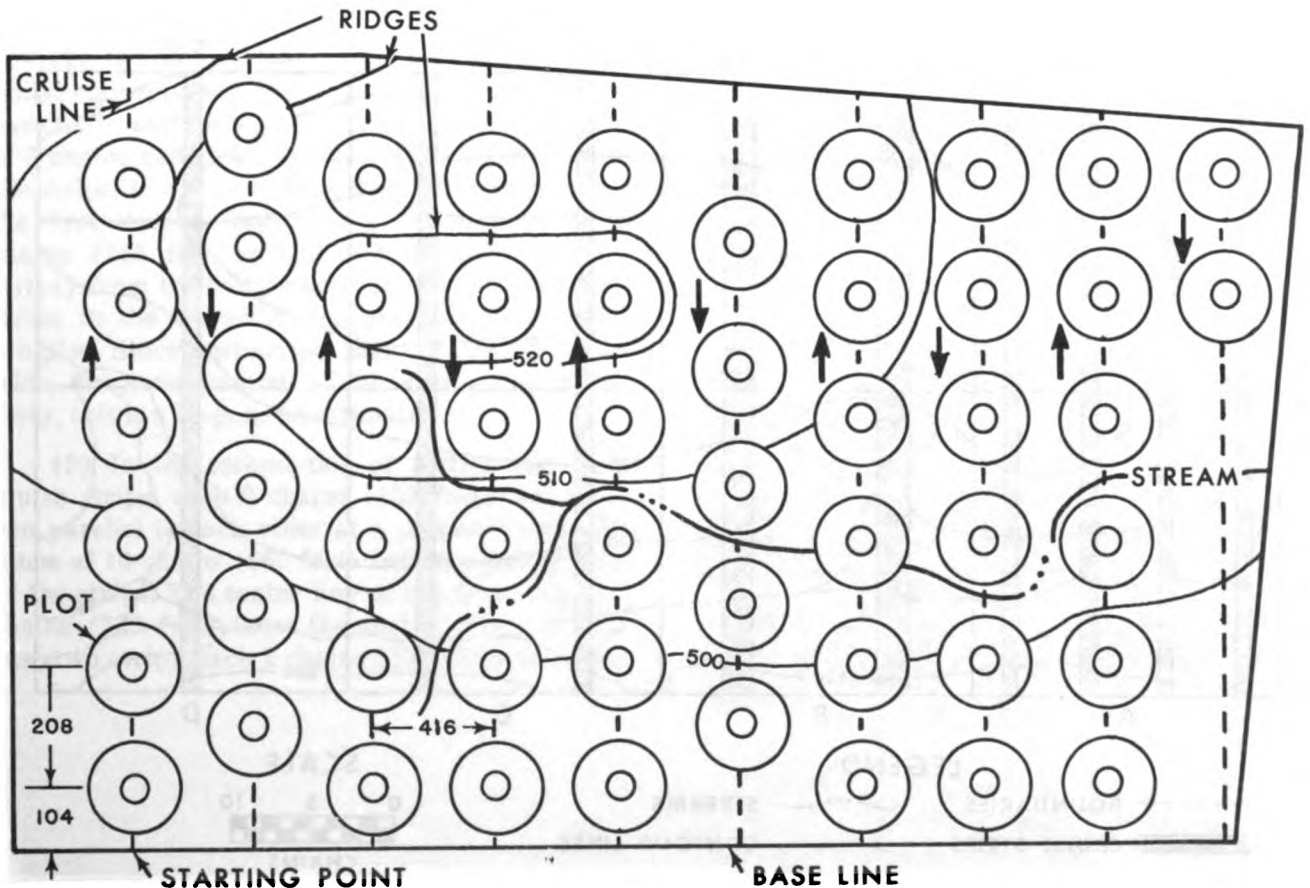

Figure 2-10. Plot method of estimating timber.

a. *Base Line.* In setting up the partial estimate a base line is plotted on a map of the area to be estimated. Cruise lines are run perpendicular to this base line. The location of the base line is chosen so that the cruise lines cross streams and ridges perpendicularly. Since forest type boundaries usually follow contour lines and there is nearly always a transition zone between adjacent forest types, crossing these contours at right angles gives the most accurate results.

b. *Location of Plots.* The plots are located along the cruise line at intervals equal to a quarter or a half of the interval between lines. For example, the plots shown on figure 2-10 are located 208 feet from each other and the distance between the cruise lines is 416 feet.

c. *Plot Size.* Samples containing a quarter or a fifth of an acre are easier to measure than larger plots and, since more of them are used, are likely to be more accurate. One acre is an area approximately 208 feet by 208 feet. A quarter of an acre is 104 feet by 104 feet or, if round, 118 feet in diameter. Round plots are usually easier to estimate than square ones.

d. *Size Criteria.* In establishing the size of the plot, the following criteria apply: for young, dense, even-aged uniform stands, smaller plots are used; for older, uneven-aged stands of light density, larger plots are best.

e. *Crew Duties.* The two-man crew is best for estimating timber by the plot method. The crew is composed of a compassman and a cruiser. The compassman serves as head chainman, mapper, and recorder. The cruiser measures the timber, acts as rear chainman, and establishes the radius of the plot. The cruiser is usually the party chief.

f. *Measurements on the Plot.* Generally, the plot system uses a smaller percentage of samples for an estimate than the strip method (para 2-14). It is essential, therefore, to measure the trees on the plot with special care. In most cases the dbh of every tree should be measured and recorded. Usually the heights of one to five trees selected at random on each plot are measured with a reliable height measuring instrument. The number of trees measured on each plot varies with the number of plots in the forest type and the number of important species represented. Under average

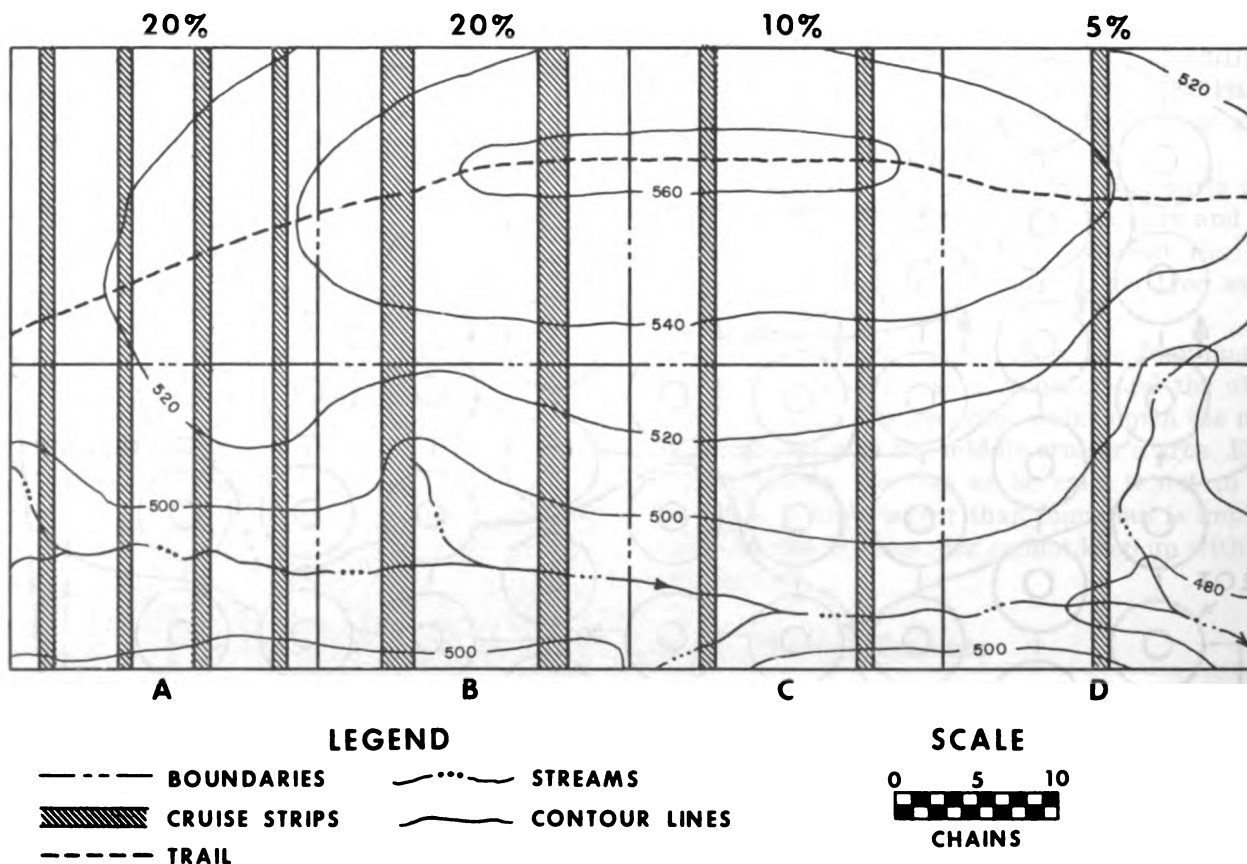

Figure 2-11. Strip method of estimating a stand of timber.

conditions, about three trees are measured for height on each plot.

g. Computing the Volume. The total volume of the area samples is computed as follows. The volume of each plot is converted to a per acre basis by dividing the plot volume, in board feet, by the area of the plot, in acres. The volumes per acre for all the plots in a type are added together and the sum is divided by the number of plots in the forest type to find the average volume per acre for the type. This average volume per acre is then multiplied by the total number of acres to obtain the estimated total volume for the forest type.

2-14. Partial Estimates by the Parallel Strip Method

The parallel strip method (fig 2-11) of estimating timber is most commonly used in making partial estimates of large stands of timber.

a. Base Line. A base line is established and the cruise line is run perpendicular to the topography.

b. Layout of Strips. The location of the sample in the parallel strip method of cruising is illustrated in figure 2-11. Four different arrangements are shown for the eight 40-acre squares pictured.

(1) In the first tier of two forties (A), four cruise strips, each 1 chain (66 feet) wide, are run parallel to each other at a perpendicular distance of 5 chains (330 feet) between the center lines of the strips. It will be noticed that the center line of the first strip is begun at a distance of 2-1/2 chains (165 feet or half the distance between strips) from the forty corner in order to place the strips in the center of the area which is being sampled. Since four strips, each 1 chain (66 feet) wide, are measured out of 20 such strips in the forty, this is a 20-percent estimate.

(2) In the second tier of forties (B), two cruise strips, each 2 chains (132 feet) wide, are run parallel to each other at a perpendicular distance of 10 chains (660 feet) between center lines of the strips. The center line of the first strip is 5 chains (330 feet) from the forty corner. In this case two strips, each 2 chains (132 feet) wide, are

measured out of a possible 10 such strips; this is also a 20-percent estimate.

(3) In the third tier (C), the arrangement of the strips is the same as in (B), but the width of the strip is only 1 chain (66 feet). Since half as much area is measured in (C) as in (B), this is a 10-percent estimate.

(4) In the fourth tier (D), the measured strip runs precisely through the center of each forty, 10 chains (660 feet) from each corner of the forty. Thus, the strips in adjacent forties would be 20 chains (1320 feet) apart. In this instance, one strip 1 chain (66 feet) wide is run. This is a 5-percent estimate. If the width of this strip were 2 chains (132 feet) instead of 1, the cruise would result in a 10-percent estimate.

c. Width of Strips. The choice of width of strip depends mostly upon the character of the timber being cruised. Density of timber, amount of brush, size of timber, and uniformity of timber are important criteria in making this choice. In short, the strip is made as wide as is practical within the limits of speed and accuracy.

d. Measurements on the Strip. The procedures for measuring the trees on the strip are practically the same as those for the plot method. Ordinarily the dbh of every tree is recorded. Unusually large trees are always measured with instruments. Where the timber is very uniform, it may be sufficient to record every third, every fifth, or every tenth tree. The exact number of trees measured will vary with almost every stand; therefore, the cruiser must decide which system of measuring will give the most accurate results.

e. Crew Duties. Although cruising parties may consist of crews containing up to four men, the most efficient crew consists of two men. One man serves as compassman, mapper, and head chainman and the other man serves as cruiser, recorder, and rear chainman. These duties can be varied somewhat to conform to local conditions. The cruiser is usually the crew chief.

f. Computation of Volume. The computation of volume is the same as given in paragraph 2-13g.

CHAPTER 3

LOGGING CREW AND EQUIPMENT

3-1. Engineer Forestry Team

a. Capability. The forestry team GA is organized under Tables of Organization and Equipment (TOE 5-520G). The TOE prescribes the personnel and equipment necessary for logging and sawmill operations to produce rough lumber and timber piling, and for equipment maintenance. The team is divided into the team headquarters (leader, sergeant, cruiser, mechanic, welder, supply specialist, and driver), the logging section (para 3-2 and 3-3), and the sawmill section (para 10-2). It can produce 10,000 to 15,000 board feet of rough lumber and timber piling per day.

b. Basis of Allocation. The forestry team, TOE 5-520G, is allocated as required. It is normally attached to a supply and service battalion of the general support group or to an engineer construction group, or it may be used to support independent, large scale operations. A team is 75 percent mobile.

3-2. The Logging Operation

Logging is the process of converting standing timber into saw logs or timber products and delivering them to the sawmill for the manufacture of lumber or heavy timber. Logging is divided into two major phases—felling the tree and preparing it for transportation, and transporting the prepared portions of the tree (saw logs) to the sawmill. These operations are performed by the logging and hauling section of the forestry team. The members of this section and their various duties are described in paragraph 3-3. Logging calls for teamwork not only between the logging crews working in the timber, but also between the hauling crew and the sawmill crew. The logs must be prepared and delivered to the mill in such quantities that a large enough supply is on hand to keep the sawmill in operation and avoid shutdowns. Logging requires the handling and movement of heavy loads. The operational and organizational maintenance of most of the mobile and heavy

equipment needed to handle these loads will be the responsibility of the logging crew. Since the logging crews are engaged in a hazardous operation, rigid safety rules must be established and complied with to prevent serious injuries to personnel and damage to equipment.

3-3. Logging and Hauling Section

The entire logging and hauling section is employed in the woods operation. This section is composed of a logging crew and a hauling crew. Each member of a crew may have several duties to perform during a normal logging operation. The logging foreman is in charge of the crews. He receives his instructions from the logging supervisor.

a. Logging Foreman.

(1) The logging foreman is responsible for the duty assignment of the logging and hauling crews. After the area to be logged has been selected, he is responsible for the planning and construction of woods roads and loading platforms. The logging foreman is the expeditor; he sees that enough logs of the correct size and type are delivered to the mill yard.

(2) Under direct supervision of the logging foreman are the lumberjacks, the vehicle operators, the air compressor operator, the tractor operator, and the log scaler.

b. Lumberjacks. The lumberjacks are normally assigned to felling the trees, sawing felled trees into logs (bucking), and loading the logs for transport. However, when a new logging operation is started, the lumberjacks aid in the construction of roads and loading docks in woods. If necessary, they construct log-handling and skidding devices. After the new area is prepared, they resume their normal duties of felling, bucking, and loading.

c. Hauling Crew. The hauling crew is responsible for skidding the cut logs from the woods to the loading dock. In preparing an area for logging the

hauling section uses its equipment for road construction.

3-4. Logging Equipment

The equipment issued to the logging crew is adaptable to nearly every type of logging operation. Axes and crosscut saws are still a part of the logging equipment, but for the most part, the emphasis is placed on the use of power equipment to facilitate logging.

a. Transportation Equipment.

(1) *Crawler tractor.* The crawler tractor has a maximum drawbar pull of 2,000 pounds and is equipped with an angledozer and front- and rear-mounted drum winches. Its primary use is for the transportation of logs by arch skidding, ground skidding, log-wagon hauling, sled skidding, and winching (single or double-drum logging). In addition to log transportation, the crawler tractor may be used for road construction and maintenance, construction of fire lanes or guards, preparation of camp sites, loading of vehicles, snow plowing, and transportation of supplies.

(2) Tractor, walking, power (20 horsepower).

(3) Truck, cargo, 2-1/2-ton.

(4) Truck, bolster, 5-ton with winch.

(5) Truck tractor, 10-ton with midship winch.

(6) Trailer bolster, swivel bolster, 9-ton, 4 dual wheels.

(7) Semitrailer, low bed, 25-ton, 4 wheel.

(8) Chain saw attachment, tractor.

(9) Truck lift fork, 10,000-pound capacity.

b. *Logging Arch.* The track-mounted logging arch is used for skidding logs over rough terrain. Working in combination with a crawler tractor, it is the most generally useful skidding device available. The operation of this logging arch is described and illustrated in paragraph 7-6.

c. *Chain Saw.* The gasoline driven chain saws issued to the logging crew can be used for felling, limbing, trimming, and bucking.

d. *Chain Saw Sharpener.* A chain saw sharpener is supplied as part of the equipment allowance.

e. *250 CFM Truck-Mounted Air Compressor.* The truck-mounted air compressor is used to power the pneumatic tools.

f. *Other Equipment.* In addition to the items listed above, TOE 5-520G also lists those necessary for survival, such as a cooking set and tents, and for protection, such as rifles and decontamination apparatus. To date, this TOE does not include the new type of logging equipment such as the grapple, the grapple carriage and skyline yarding equipment, the power sorting and loading fork, and area illuminating equipment. This new equipment is discussed in chapter 7.

3-5. Woods Safety

a. The natural and sometimes unforeseen hazards of woods operations make logging a potentially unsafe operation. The number of persons injured or killed each year is higher in proportion to the number employed than in most other industries. This indicates a need for more attention to safety on the part of everyone employed in the woods operation.

b. To do this, safety must be considered in the first stages of forest engineering, where the planning of the operation begins. The location of landings and truck and skid roads; the direction of fall of hillside trees; and the schedule of areas to be logged determine, to a great extent, the relative safety of the entire logging operation.

c. In the road construction which must precede the logging operation, safety must also be considered. The grades, width, and evenness of roads, and the visibility on sharp curves, turnouts, and bridges, must be designed to reduce possible hazards to operators of crawler tractors, earth-moving equipment, and trucks.

d. Supervision of these operations, and those that follow, should be carried out with the assistance of a safety organization. This safety organization should consist of one person in charge, and such safety committees as may be practical to check on the details of safe operation.

e. Personnel should be issued safety (steel-toed) shoes, if obtainable, and helmet liners should be worn by all those actively engaged in the logging operation.

CHAPTER 4

LOGGING ROADS

4-1. Definitions

A logging road is also called a "woods road." Either term is used to designate any one of the three basic types of roads used in the logging operation. The following nomenclature will identify the types according to their use:

a. Truck Road. The truck road is a semipermanent all-weather road capable of handling heavily loaded log trucks moving from the log loading dock to the sawmill site. Construction of this road is sometimes highly complex and is usually done by an engineer construction unit.

b. Primary Skid Road. The primary skid road is used by the log-skidding vehicles to move the logs from the cutting site to the log loading dock located adjacent to the truck road. The primary skid road usually is not more than a mile long, and is usually located so that it is within 200 feet of the trees to be cut. The primary road is constructed to withstand erosion and the movement of the loaded skidding vehicles. Construction and maintenance are usually the responsibility of the forestry company.

c. Secondary Skid Road. The use of a secondary skid road is not recommended unless absolutely necessary. Its use is limited to areas inaccessible to the normal skid road. The secondary skid road in most cases ties into the primary skid road system. This road may be typified as having extremely steep grades, poor drainage, narrowness, and primitive construction. Ordinarily, the secondary skid road is used once or twice and then abandoned; there is no attempt at maintenance. When the road is abandoned, slash (the debris left after logging), brush, and grass seed should be used to prevent erosion.

4-2. Planning of Skid Roads

Although the construction of the truck road is the responsibility of a construction unit, the forestry company is responsible for developing the plan for both truck and skid roads. The primary

concern is meeting the requirements of alignment and grades. For the most part, these requirements are the same for both types of road, with more variation occurring in the skid road layout. As the logging operation extends farther into the woods, skid roads may be converted into truck roads. The master plan should, therefore, differentiate between the skid roads that will develop into truck roads and those that will not. Those that will become truck roads are constructed to meet the truck road requirements for alignment and grades. This avoids delays in converting a skid road to a truck road. Detailed information on road construction is given in TM 5-330.

a. Differences Between the Normal Military Road and the Skid Road. The primary differences between the military road and the skid road are in road width and roadbed construction. Whereas the minimum width requirement on the military road is 18 feet, the minimum width of the skid road is 12 feet. The bed of the skid road is made up entirely of material in place; the military road requires more elaborate preparation. The requirements for drainage, percent of grade, and graduation of curves are generally the same for skid roads as for military roads. However, in the interest of economy and time, the construction of the skid road may vary from these standard military practices.

b. Economy in Construction. If it is necessary to haul in fill or carry out extensive compaction operations, it is not economical to build a skid road for most logging operations. Construction of bridges and culverts is held to a minimum and only the simplest of structures should be used. The width of the skid road may vary slightly but usually it is just wide enough to accommodate the skidding vehicle. At intervals along the skid road, turnouts may be constructed to facilitate movement of two-way traffic. While the skid road is a necessary part of almost every logging operation, prohibitive construction time and costs can restrict its use and require the use of other skidding methods. Also, the limited road construction

equipment available to the forestry teams will limit the extent of road construction.

c. Location of the Road With Respect to Topography.

(1) If available, a topographic map of the area should be studied to obtain a fairly accurate idea of the topography and drainage pattern. A tentative layout can be made of the skid road system by using only the map.

(2) Aerial photos are also useful. If stereopairs are available they can be used to obtain a third-dimensional view of the terrain. From these, features of the terrain can be studied that are not shown on the topographic map.

(3) Next, the area should be reconnoitered on foot to check the topography against the map. Notes should be made of ledges, rock bars, old railroad beds, minor streams, and other features that are not apparent on maps or aerial photographs. Special attention should be paid to the tentative location of turnarounds, landings, and so on. An Abney level is useful for checking grades during the reconnaissance.

(4) After the reconnaissance the final layout can be made. There may be adjustments here and there in the tentative plan to avoid a rock ledge or a difficult stream crossing that was discovered during the reconnaissance.

(5) In low, swampy areas it may be necessary to "push up" a roadbed from the area immediately adjacent to the proposed road site. How-

ever, if the soil in place cannot accommodate normal skid loads, then another method must be devised to remove the logs from the forest.

(6) The alinement of skid roads is critical in that the log-skidding vehicles, when loaded, may be up to 70 feet in length. As illustrated in 1 of figure 4-1, the curve should be gradual to keep the arch and logs from leaving the road (2, fig 4-1). The location of turnouts on curves will aid the log-skidding vehicle in negotiating turns.

(7) Examples of overall layouts for gentle and steep grades are shown in 1 and 2 of figure 4-2. A good layout for a gentle slope, 1, is typified by straight trails and moderate curves. For steep slopes, 2, there are zigzags to reduce grades. However, it should be noted that there is still a tendency to use moderate curves even on the steep slopes. A poor layout for a gentle slope is shown in 3. This sketch shows the sharp curves which make the travel slow and increase the skidding distance.

(8) When the road or roads are laid out on the ground, control points are established. The road location is determined between control points, then the center line is blazed.

d. Maximum Desirable Grades. The grades on the main skid road should be kept as low as the topography permits, because there is a possibility that it could ultimately be converted to a truck road. On the lower slopes, grades should be less than 10 percent. On the higher slopes where there

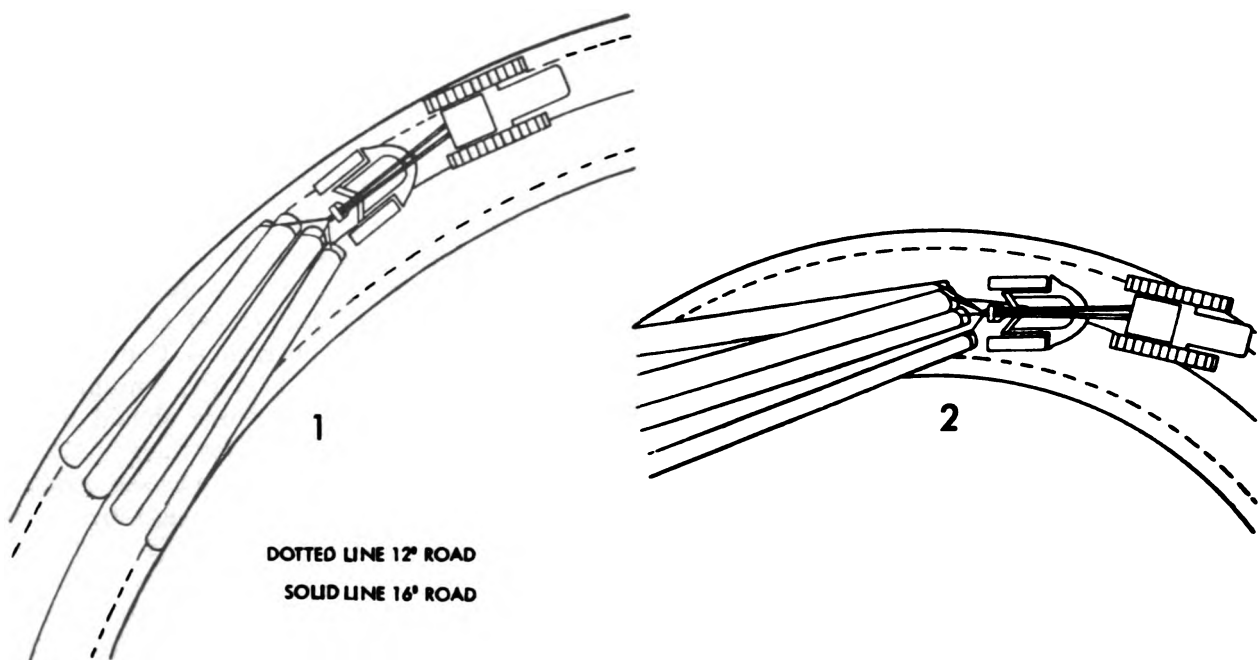

Figure 4-1. Lengthening a curve for tractor-arch logging.

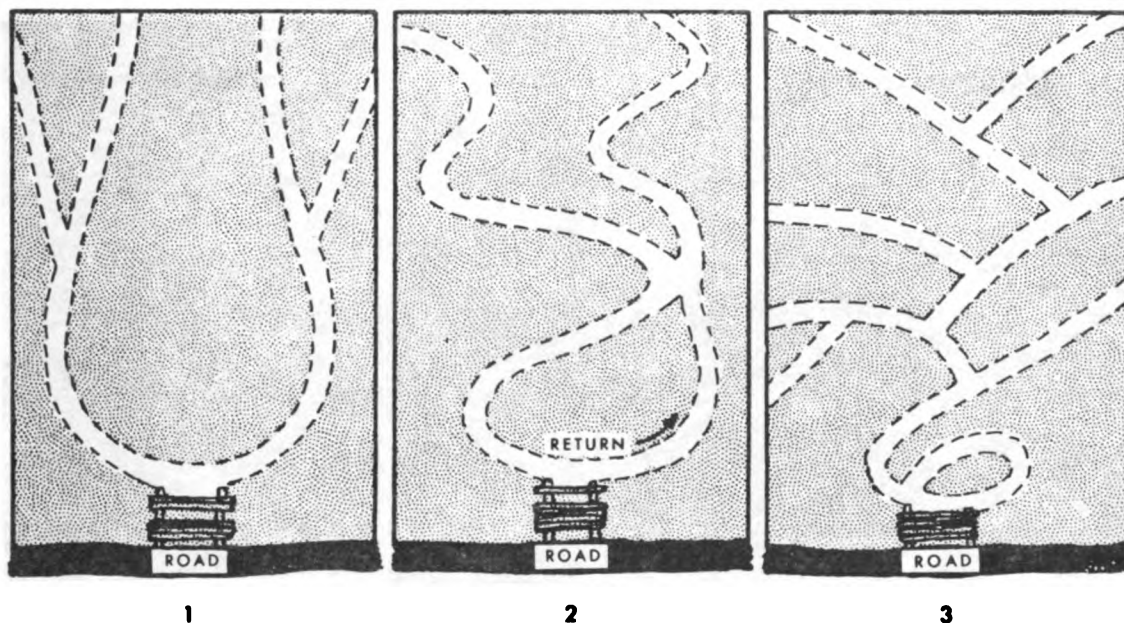

Figure 4-2. Layouts of skid trails.

is less possibility that the skid road will be converted into a truck road, the grades may be steeper if topographic obstacles make it necessary or if excessive mileage would have to be constructed. Long straight grades should be avoided because they let water build up force and cause erosion.

4-3. Construction of Skid Roads

Since the forestry team or company has limited road construction equipment, it normally builds only skid roads. The construction methods should be simple, using material and equipment on hand.

a. Roadbed. The roadbed should consist of the material in place or material immediately adjacent to the road site. Limited quantities of gravel and dirt fill can be hauled to low or swampy sections of the road. Slash, slabs, and logs can be effectively used as fill material. The skid road cannot be maintained as a crown type road, so the entire surface of the roadbed should have a transverse slope in order to allow water runoff. The roadbed should be compacted with the crawler tractor only enough to maintain the weight of the loaded tractor and arch.

b. Method of Construction.

(1) Wherever possible, build the road from the top of the grade down. Driving the tractor to the top may require weaving around large trees, ledges, and steep slopes, but the effort is not wasted. The time spent is offset by the saving gained by downhill dozing.

(2) Do not chop down trees that can be pushed over by the bulldozer. Bulldozing them saves time and eliminates the need for taking out stumps.

(3) Use a two-man crew. One man operates the bulldozer while the other cuts brush, warns the operator of any dangerous obstructions, and performs other jobs the operator thinks necessary.

(4) Give the skid road a slight transverse slope whenever possible. This permits the water to drain off and prevents washouts in the road.

(5) Military roads which have a transverse slope are usually slanted into the side of a hill to prevent erosion of the outside shoulder and to throw skidding vehicles into the hill rather than out. However, this method usually requires the construction of extensive drainage systems which are not warranted on skid roads. To avoid the extra construction, therefore, a skid road alongside a hill may be slanted out.

c. Examples of Construction. Examples of completed woods roads are shown in figures 4-3 and 4-4. The skid road (fig 4-3) is an example of a woods road used exclusively for skidding logs. Its grade indicates that it is near the top of the elevation of the area being logged. The woods road shown in figure 4-4 is a skid road that has been developed into a truck road. The slope in this road is considerably less.

d. Development of Switchbacks. In mountain



Figure 4-3. Skid road.

logging it may be necessary to develop switchbacks in order to ascend and descend a slope. As shown in figure 4-5, the road forms a zigzag pattern along the side of the mountain. The slope of the road should not exceed 10 percent. The switchbacks should be located at convenient points, and must have enough area to furnish turnaround space for the log skidding equipment which, when loaded, may exceed 70 feet. A switchback 100 feet wide as shown in figure 4-5 provides enough room for turning around.

e. Erosion Prevention. Erosion precautions fol-

low the normal pattern of road construction. The simplest possible culverts should be constructed where the road crosses a gully or wide area depression. The bed of the road should slant in the direction of drainage. General surface erosion can be prevented or curtailed by placing slash and brush on the road surface. If the road is to be idle for a long time, it is recommended that grass be sown to help stabilize the soil. Water bars (fig 4-6) are useful for protecting roads that are not in use. The intervals between the bars depend on the grade and are shown in table 4-1.



Figure 4-4. Truck road.

f. *Maintenance.* Regular maintenance of dirt skid roads is essential in maintaining a smooth flow of logs to the sawmill. Much of this maintenance is done by hand, but for large jobs such as repair of washouts, landslides, and rock slides, the bulldozer is a good tool. For regular work over the entire road system, a grader is more efficient and time-saving.

4-4. Safety in Road Construction
 Safety in roadbuilding must be considered in the

standards of construction and also in the construction job itself.

Table 4-1. Distance Between Water Bars

Grade (percent)	Distance between water bars (feet)
2	250
5	185
10	80
15	60
20	45



Figure 4-5. Development of switchbacks.

a. Safe standards of construction include the following:

(1) Road grades should not be too steep for safe operation of the logging vehicles. They should not exceed 25 percent unless a power winch and cable system or other auxiliary means of lowering vehicles is provided.

(2) Sufficient turnouts should be provided, and a safe side clearance should be maintained along all roads. Brush that might obstruct the view at an intersection or on extremely sharp curves should be cleared.

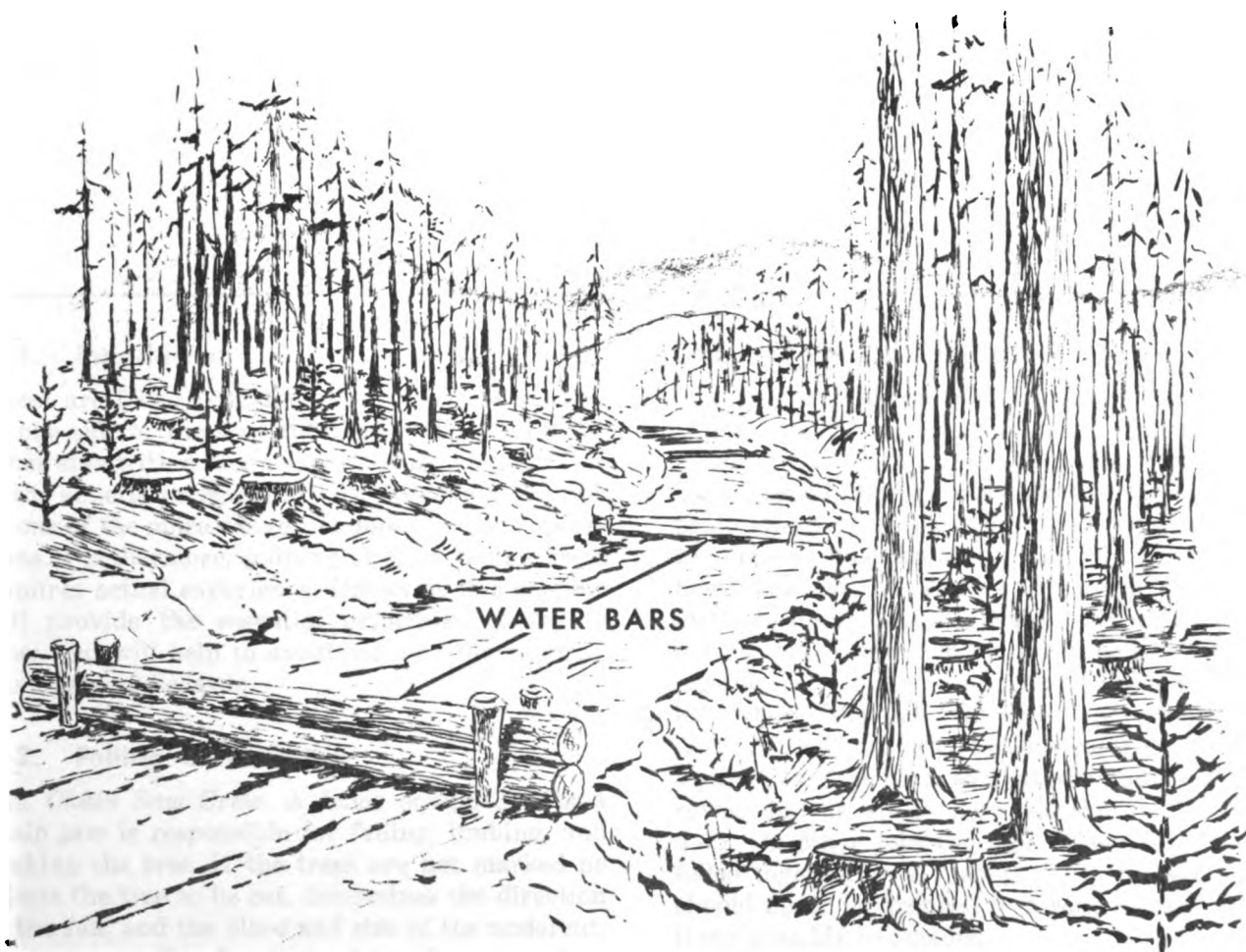

Figure 4-6. Location of water bars.

(3) Bridges and crib work should be built substantially to withstand any side thrust or other force that might be imposed on them. Footings should be firm and adequately protected against the weakening effect of water and ice.

(4) Substantial guard rails or wheel guards should be installed and securely anchored on all bridges and trestles.

b. To make the construction job safe—

(1) Tractor operators should not be permitted to work alone or out of frequent contact with another person who could help in case of accidental injury.

(2) Adequate lighting should be provided if road construction is carried on at night.

(3) All men should watch for cave-ins, rolling rocks, flying stones or branches, and other such hazards, and work should be laid out to eliminate the exposure of men to these hazards.

CHAPTER 5

FELLING

5-1. Introduction

Trees are felled (cut down) by chopping a notch in one side of the tree and then cutting from the other side with a chain saw or crosscut saw. This is the general principle and an over-simplification of one of the more dangerous jobs in woods operations. Furthermore, gaining skill in felling trees requires actual experience. However, this chapter will provide the essential principles of felling trees and will help to avoid some of the common mistakes and hazards.

5-2. Felling Crew Duties

a. Chain Saw Crew. A feller equipped with a chain saw is responsible for felling, limbing, and bucking the tree. If the trees are not marked he selects the tree to be cut, determines the direction of the fall, and the place and size of the undercut. He is responsible for the safety of personnel in the area of the falling tree and gives the warning, "TIMBER," just before the tree falls. The feller may have an assistant equipped with an ax to increase operating efficiency and to promote greater safety. The assistant removes trash accumulated in cutting, and aids in lifting pieces for their proper cutting. During bucking he limbs the tree and the feller measures the tree for log lengths.

b. Crosscut Saw Crew. The crosscut saw crew is a two-man crew, the head feller and the second feller. The head feller carries the saw and one double-bit ax. If the trees have not been previously marked for cutting he selects the tree to be cut. He determines the direction of fall and the size of the undercut. After assuring himself that nearby workmen have moved to safe positions, he directs the felling of the tree and gives the warning, "TIMBER," just before the tree falls. The second feller carries one double-bit ax, a sledge hammer, and wedges. He acts as the assistant to the head feller. During bucking he is responsible for limbing the tree while the head feller is measuring the tree into log lengths.

5-3. Layout of Felling Job

a. The general layout of the felling job is highly important. The logging foreman is responsible for a layout that saves time and work. Since felling (often called falling) is the most dangerous job of the logging operation, the person in charge and the fellers must know all possible dangers and how they can be avoided by using the proper methods for felling the timber. Where conditions permit, much time and work can be saved by felling the trees so that the tops and branches can be left where they fall. On some operations where parallel roads are provided, all the trees are felled away from the road so that the tops are wind-rowed in the space between the roads (1, fig 5-1). On other jobs the tops of several trees are felled together in a "jackpot" (2, fig 5-1). Tops should never be dropped in a road or skid road if it can possibly be avoided.

b. It is important, particularly on jobs where long logs are to be skidded, to fell the trees so that they can be transported more easily. This requires felling them with butts toward the road at about a 45° angle (3, fig 5-1). On some softwood jobs in dense stands of timber exactly the opposite course is followed. The trees are felled away from the remaining standing timber, with their tops toward the road (4, fig 5-1). This reduces lodging (hanging up in an adjacent tree rather than felling free to the ground). Also, a heavier load can be carried under the logging arch when the trees are hauled in top first.

c. Another method to be considered, especially when the tractor and logging arch are to be used for skidding, is to start the felling operation at the far end and top of the logging area and work toward the log landing. This prevents working over and through limbs and tops from previously felled and limbed trees.

5-4. Direction of Fall

a. Before starting to use the ax or saw on the tree, it is necessary to carefully examine the tree

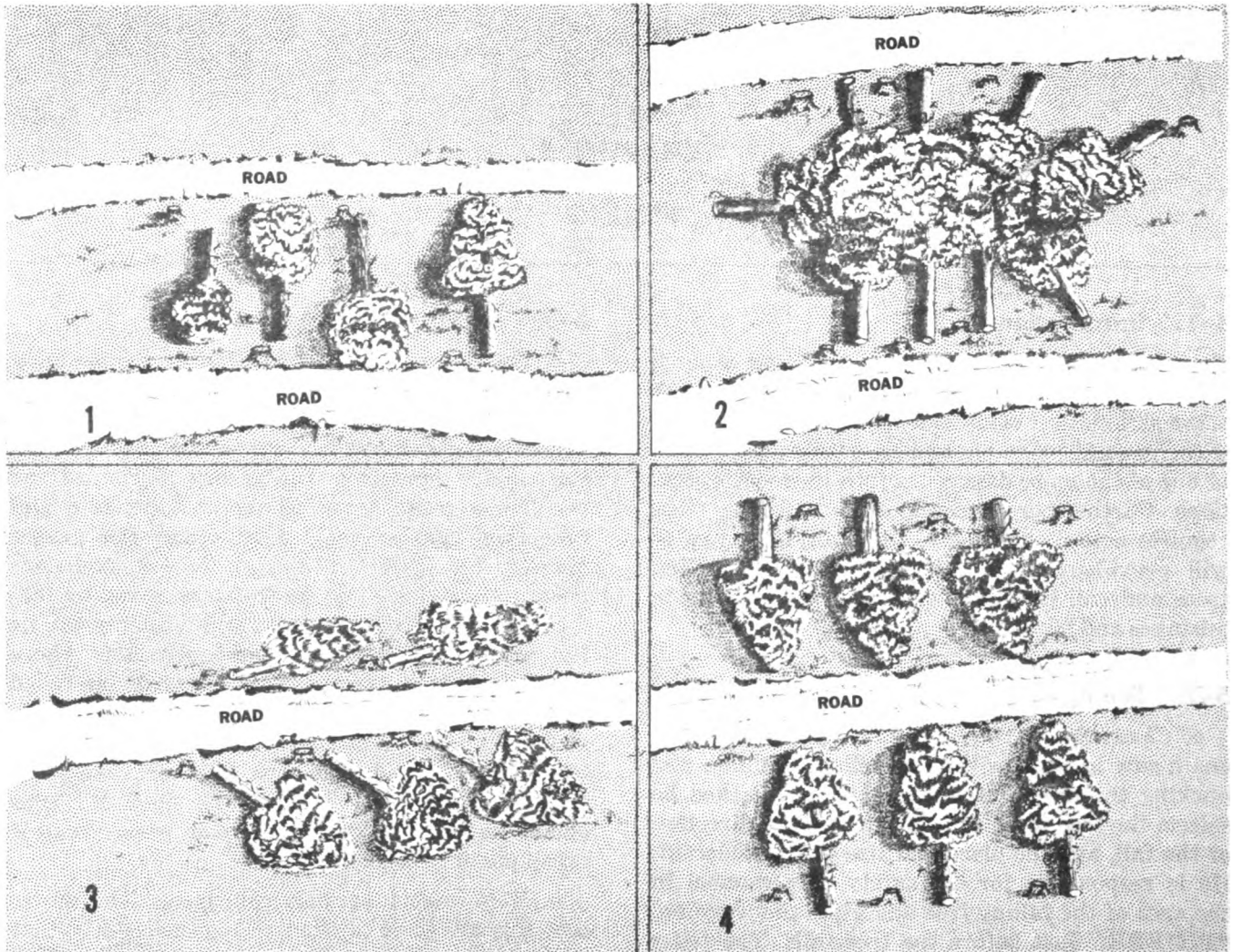

Figure 5-1. Felling patterns.

and its location and decide just where the tree should be dropped. The choice is usually limited by the layout of the operation and the location of the tree. If the tree is leaning not more than 5°, has about the same amount and size of limbs all the way around, and is not being pushed by a strong breeze, the fellers can drop it in about any direction they choose. This is done by the proper location of the undercuts, by the use of wedges between the stump and log to tip it on the stump, and sometimes by the use of a long spiked pole, which is pushed against the tree trunk 15 or 20 feet above the ground. The latter method is not recommended because the pole may slip and allow the tree to tip suddenly and fall on the worker.

b. Big trees that lean noticeably or have heavy branches on one side can seldom be thrown in the opposite direction without the use of a block and tackle or other similar equipment, ordinarily not

available in the woods. Most of the leaners, however, can be thrown 45° to the right or left of the direction in which they would naturally fall. It is up to the feller to decide just where in this arc his tree should be directed. It is dangerous to fell a tree into another. Deflection of the falling tree may cause the tree to hit personnel or dead branches may fall on the feller. These branches are called "widow makers."

c. It is also unwise to fell a tree straight up a steep slope. The tree may bounce as it strikes and slope and kick back over the stump to strike the unsuspecting feller. The best way is to fell the tree diagonally along the hillside and seek safety on the upper side of stump away from the direction of the fall. Trees felled straight down a steep slope are likely to be shattered by the fall, particularly if the ground is rough. It is bad practice to let a tree fall across a large rock, stump, or an-



1 Clearing away small brush



2 Clearing away saplings

Figure 5-2. Clearing away small brush and saplings.

other log as these tend to break the trunk and cause waste of much of the good timber. Another thing to be considered in felling a tree is that it may become lodged in the branches of another tree, wasting time and causing trouble.

5-5. Clearing Working Space

Once the direction of fall is determined, the next step is to clear away brush and low-hanging branches that could interfere with the use of the ax or saw as the feller works at the base of the tree. Small brush is clipped off close to the ground by holding the ax in one hand near the point of balance and the brush in the other. Pulling on the brush provides the necessary resistance to a slicing cut (1, fig 5-2). Larger brush and small trees (2) are also cut in this manner by bending the stem first one way then the other while making slanting downward cuts. Low-hanging limbs are removed in the same way.

5-6. Safety in Brushing Out

- a. Check ax handle for cracks, splits, or splinters.
- b. See that the axhead is tightly wedged and that the blade is sharp.
- c. Look over the ground around the tree for rocks, logs, or holes which might cause falls.

d. Check the tree for hanging branches that might fall on or be in the way of personnel felling the tree.

e. Wear a hard hat for protection against falling branches.

f. Wear calked shoes, except when working on large rocks which might be slippery.

g. If carrying a saw, place saw on ground away from the working area before starting to brush. Do not set saw where it can fall on or trip personnel.

h. To prevent concentrations of flammable materials, scatter cut brush and saplings over a wide area.

i. Never embed a double bladed ax in a stump or tree. Lay it flat on the ground and in the open where it can be easily seen.

5-7. Making Undercut (Notching)

a. The undercut is made on the side toward which the tree is to fall. Its functions are to provide a fulcrum and hinge point on which to tip the tree off its stump. The stump should be not more than 12 inches above the ground level. High stumps waste timber and hinder skidding. Exception to the 12-inch rule must be made, of course,

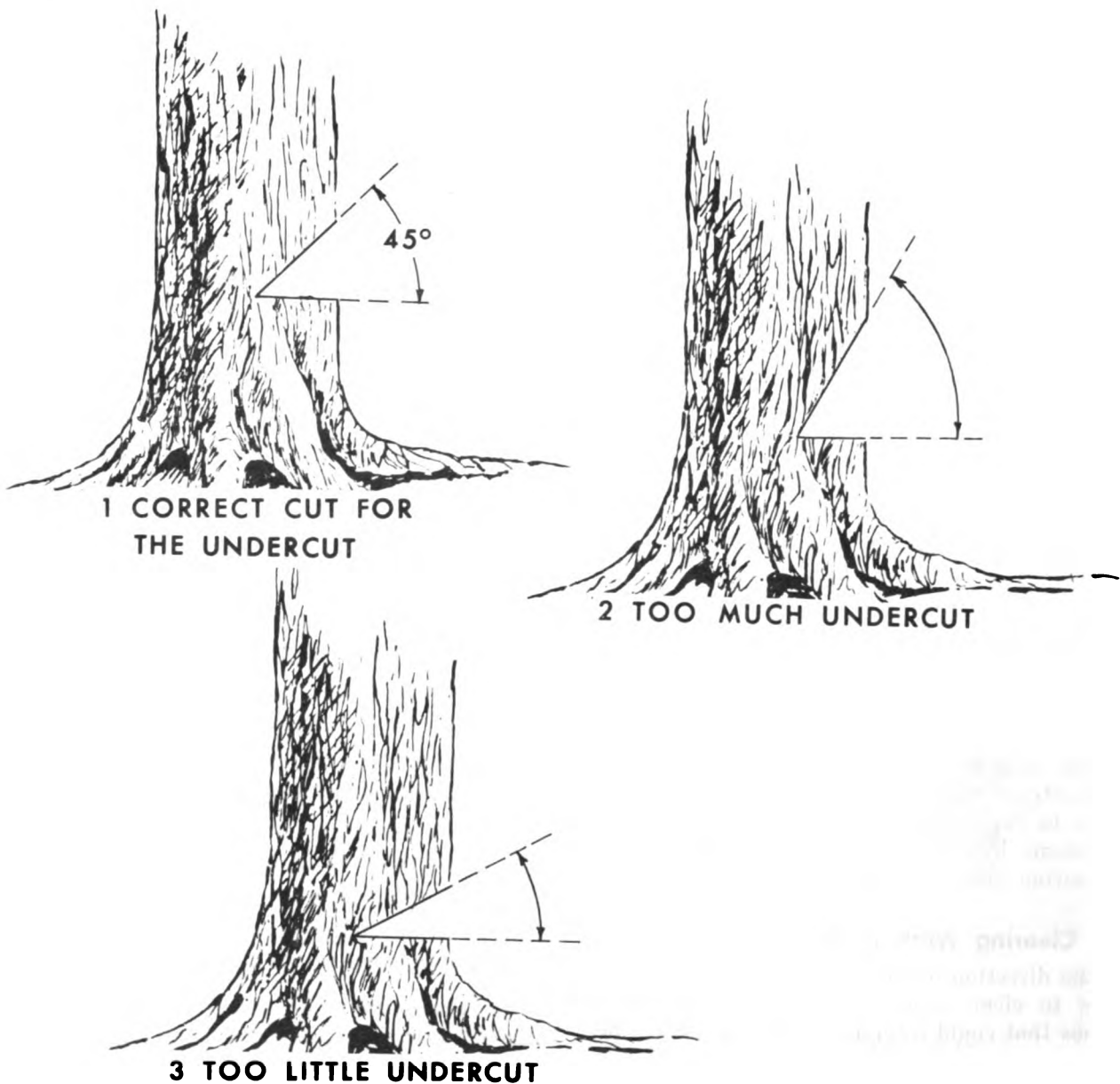

Figure 5-3. The undercut.

when a rock or some other obstruction makes a low stump impossible. If a chain saw is used, the entire undercut is made with the saw. If a cross-cut saw is used a horizontal cut is made to a depth of about one-fourth of the diameter of the tree and the notch is chopped out. The usual practice is to chop the notch above the saw cut on a 45° angle (1, fig 5-3). A larger notch (2) requires unnecessary chopping and a smaller one (3) is too hard to make.

b. An inexperienced chopper will have trouble in getting the chips to fall out properly. The best method of chopping is to bury only part of the ax edge in the wood at each stroke. If the heel or the

nose of the ax is exposed, the chip tends to roll off easily. This can be done by working first the near side, then the far side, and lastly the center of the undercut. In large trees it is necessary to cut a small notch first and then chip down the full sized notch (1, fig 5-4). In extra large trees it may be best to make two small notches and one large notch (2, fig 5-4). This prevents binding, thus making the chipping-out easier.

5-8. Testing Direction of Fall

When the undercut is completed it is well to check the direction of fall. The crease at the back side should be straight and at right angles to the direc-

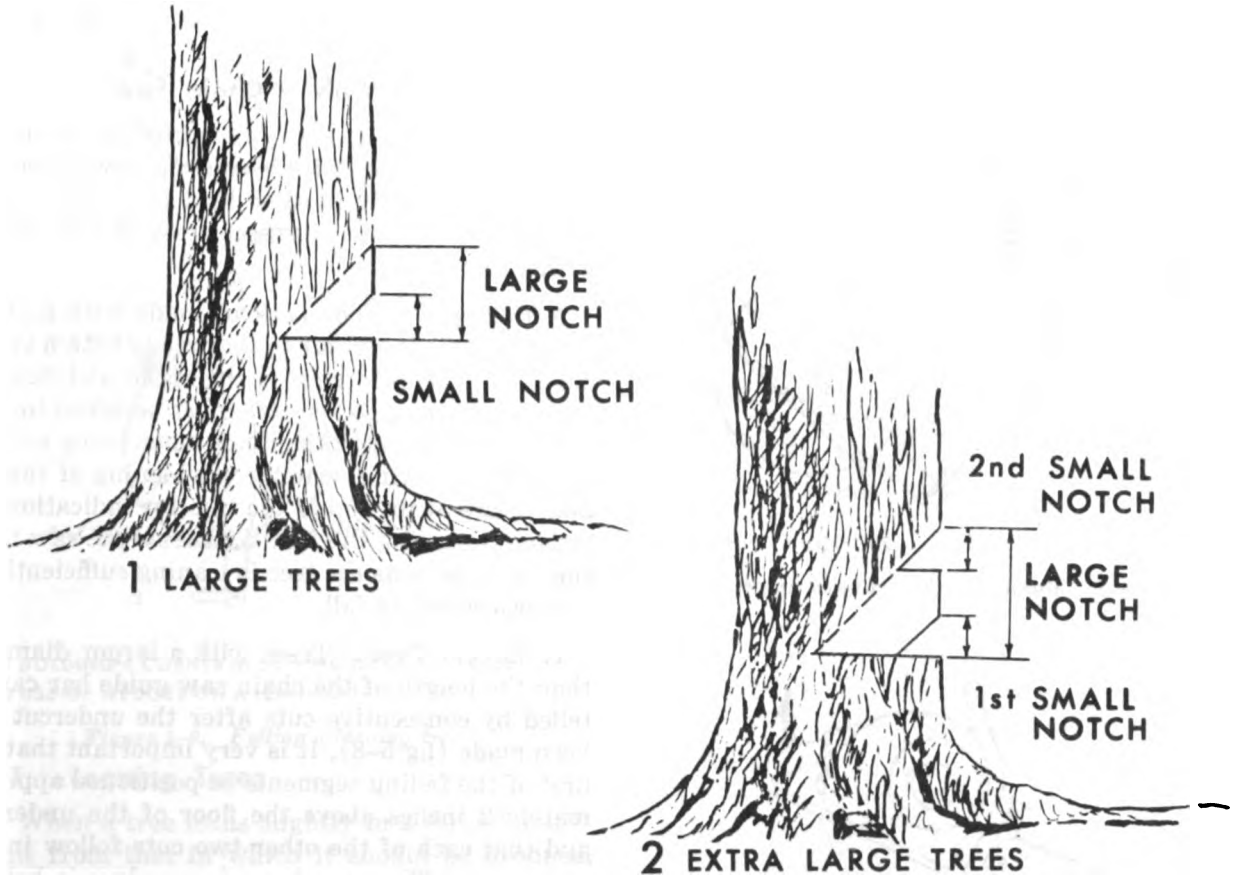
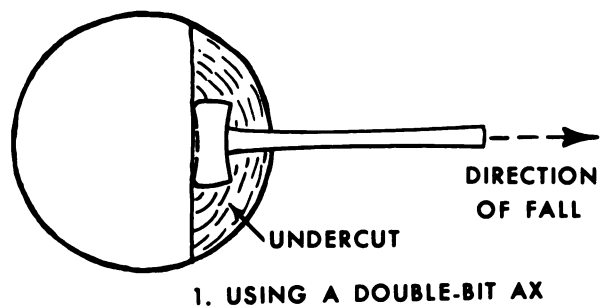

Figure 5-4. Notching a large tree.

tion in which the tree is to fall. One simple test is to push the head of a double-bit ax into the crotch made by the undercut (1, fig 5-5). The handle should then point in the direction in which the tree is to fall. Another method of determining the direction of fall is to use a gun stick (2, fig 5-5). The two base ends are placed one at each edge of the undercut. The apex then points in the direction of fall.

5-9. Making Backcut

a. The backcut (fig 5-6) should be approximately 2 inches higher than the bottom of the undercut (1, fig 5-6). The cut normally should be kept parallel with the undercut until only 2 or 3 inches of holding wood is left. If the tree has not fallen by this time, it should be tipped by driving in one or two felling wedges behind the saw. As the sawing is continued, the wedges are driven enough to maintain tension to keep the tree tilted. Do not saw to less than 1 inch of holding wood. This is needed to serve as a hinge (2, fig 5-6) that will guide the tree as it falls. When a two-man



1. USING A DOUBLE-BIT AX

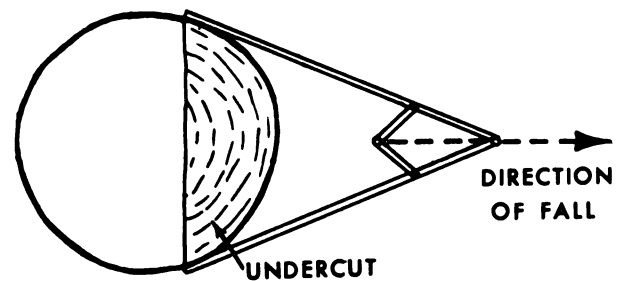

2. USING A GUN STICK

Figure 5-5. Testing direction of fall.

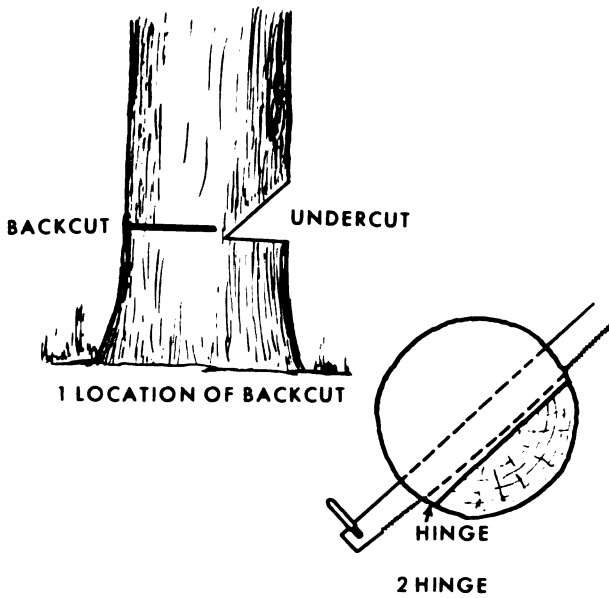

Figure 5-6. Making the backcut and hinge.

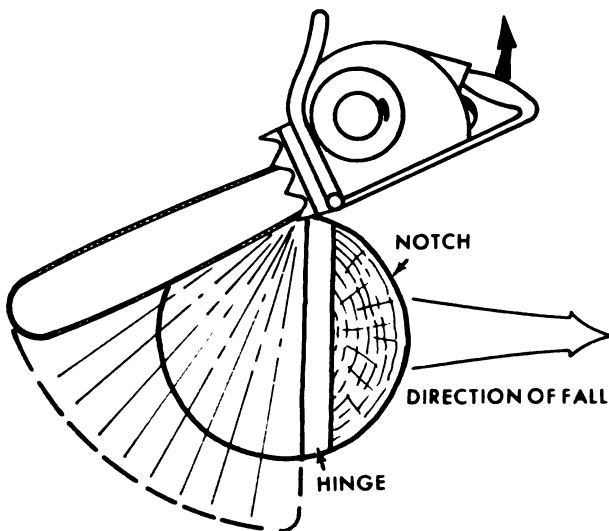

Figure 5-7. Normal felling cut.

crosscut is used to make the backcut, each sawyer should keep his partner informed of how near the saw is to the undercut so one side will not be too far ahead of the other.

b. Before starting to saw a tree, each man should plan his getaway path. The tree should be observed closely for any rotten or dead limbs that would be likely to fall when the tree is chopped or wedged. Some trees, especially if they have rot in them, fall quickly. It should be decided beforehand who will remove the saw if a crosscut saw is used. The feller should quickly move back to one

side of his sawing position (preferably behind another tree) and cautiously watch the tree as it falls.

5-10. Felling With a Chain Saw

a. *Safety Rule.* A safe rule to follow is—if the cut cannot be made with a crosscut saw, it cannot be made with a chain saw. That is, if the tree or log will “bind” with a crosscut saw, it will “bind” with a chain saw.

b. *Felling Cut.* The backcut made with a chain saw (fig 5-7) is similar to that made with a crosscut saw. The difference is the speed and flexibility of operation. Extra care must be taken to prevent cutting through the hinge when using a chain saw. While sawing, watch for widening of the cut and glance at the top of the tree for indications of motion preceding the fall. Withdraw the saw from the cut as soon as the tree is leaning sufficiently to assure a complete fall.

c. *Larger Trees.* Trees with a larger diameter than the length of the chain saw guide bar can be felled by consecutive cuts after the undercut has been made (fig 5-8). It is very important that the first of the felling segments be positioned approximately 2 inches above the floor of the undercut, and that each of the other two cuts follow in the same plane. The use of wooden wedges is helpful in assuring that the cut will open.

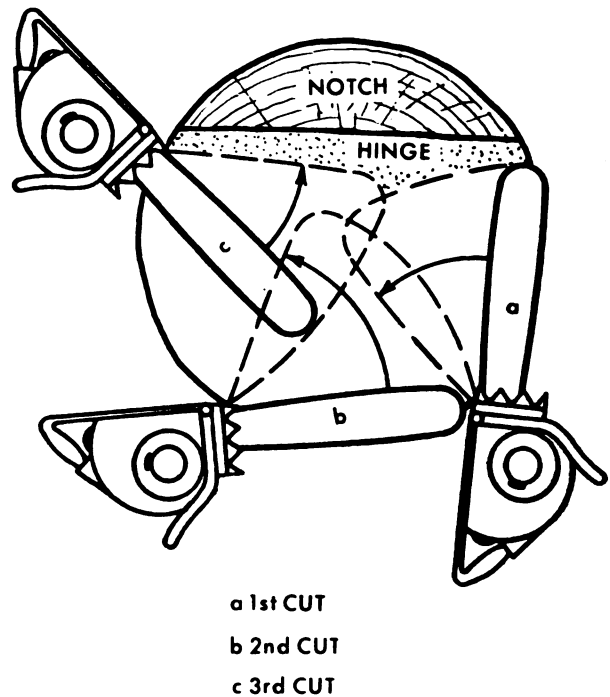
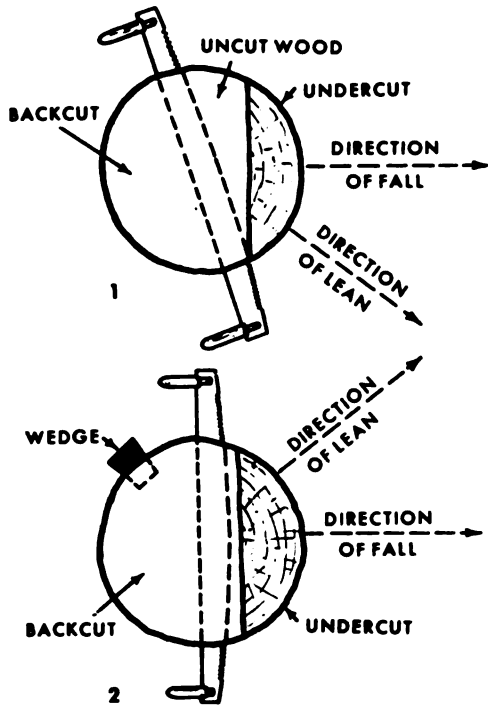

Figure 5-8. Felling cut for large diameter tree.



1 HOLDING A CORNER IN SAWING A LEANING TREE
2 USE OF WEDGES ON A LEANING TREE

Figure 5-9. Felling a leaning tree.

5-11. Leaning Trees

a. When a tree leans slightly in a direction different from that in which it should be dropped, the direction of fall can be changed to a certain extent by "holding a corner." This is done in the backcut by simply leaving more wood on the side opposite the one toward which it leans (1, fig 5-9). This acts as a holdback to twist the tree away from the direction in which it leans.

b. Wedging can also be used to change the direction of a fall. One or more felling wedges are driven into the backcut on the leaning side (2, fig 5-9) to tip the tree into an upright position from which it can be made to fall in the desired direction.

c. A gusty wind sometimes interferes with felling a tree in the desired direction. If the wind is blowing exactly in the desired direction, the fellers merely adjust their rate of sawing so that the last few inches of wood are cut when the breeze is steady enough to take the tree over. If the wind is coming from the opposite direction the problem is much more difficult. The cutters will have to time their work so that their sawing is finished exactly at the time when the wind has died down and the tree is swaying back from the force of the gust. On some days when the wind is changeable, felling may become so dangerous that it should be discontinued altogether.

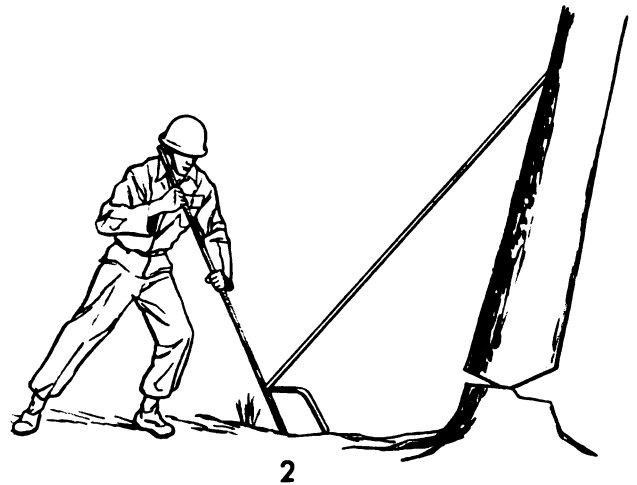

Figure 5-10. Pushing over a tree.

d. Small trees can be pushed over in almost any direction by hand. A pole (1, fig 5-10) from 12 to 16 feet long with a metal spike on the end is much safer and gives far better leverage. The end of it is held against the shoulder or against the hip, not against the stomach. For large trees where more power is necessary, a strong hard wood pole, known as a kilnig (2, fig 5-10), may be used. The pole is notched vertically at one end and a horizontal wedge point is shaped at the other. The point is placed in a notch on the tree cut as high as the axman can reach. The notched end of the pole is braced against a peavy handle just above the hinge. The pike is thrust into firm ground or

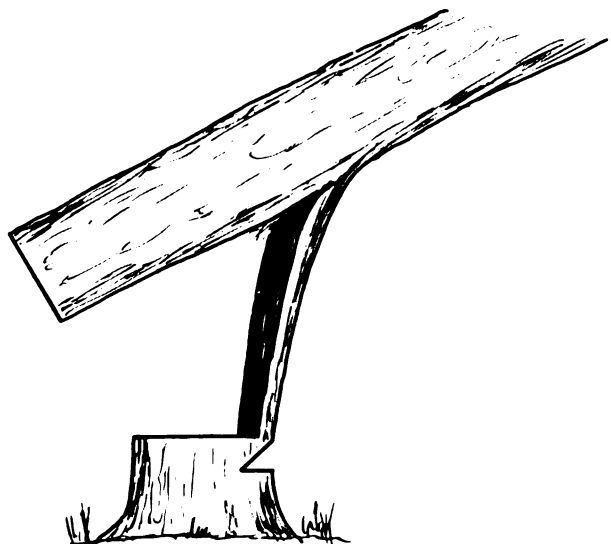

Figure 5-11. A "barber-chair" stump.

into a root if one is convenient. By pushing forward on the peavy handle, it is possible to exert several times the ordinary pole pressure against the tree and aid in directing the fall.

e. Trees leaning in the direction of fall can be dangerous. They usually fall sooner than expected, splintering the butt, and thrashing around in unpredictable directions. One common result is the "barber-chair" stump (fig 5-11), in which the most valued part of the tree is spoiled. One method that will usually prevent a leaning tree from splitting in this way is called sawing off the corners. The backcut is halted before there is any danger that the tree will fall. Then, each corner is sawed off at an angle. The same result can be obtained by chopping out the corners of the undercut (1, fig 5-12). Another method used to reduce splitting of large bad leaners or hollow-butted trees is to fasten a log chain around the base of the tree just above the backcut (2, fig 5-12). Wedges driven between the chain and the tree will tighten the chain and prevent serious splitting.

f. Some valuable leaning trees that can be dropped only in the direction of the lean can be cut three-fourths through from the leaning side by using wedges to prevent pinching the saw. The saw is then removed, and the cut completed from the backcut side. A good general rule to remember is—the greater the lean, the deeper the undercut. It is possible to fell trees 2 feet in diameter and greater in the opposite direction of lean, if required, providing the lean is not too great. In this operation the backcut is made first so that wedges

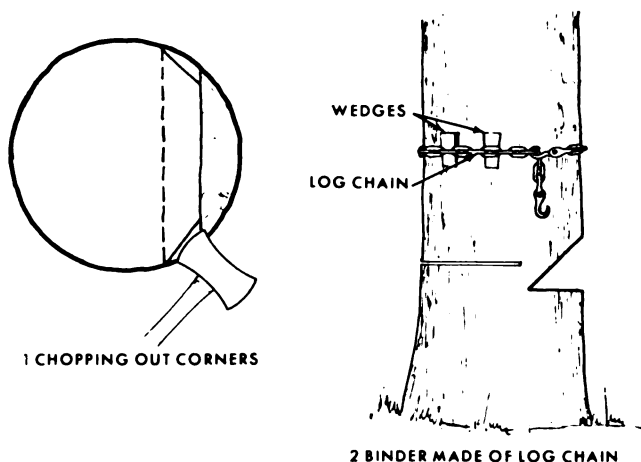

Figure 5-12. Methods used to prevent splitting a tree.

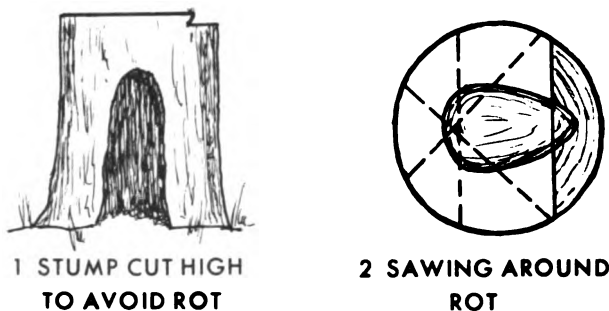

Figure 5-13. Felling rotten trees.

can be applied before the saw is pinched. Sawing and wedging is continued until the tree is in true vertical position after which the undercut is made. After making the undercut the backcut is completed and wedges are applied until the tree falls.

5-12. Rotten Trees

a. Rotten-butted trees present a difficult felling job. Extra precautions will have to be taken to try and anticipate the time and direction of their fall. A large percentage of the most serious accidents occur in attempting to bring down rotten-butted trees. If possible, the felling cuts are made high enough to avoid most of the rot (1, fig 5-13). This not only results in safer felling, but also saves the time spent sawing the rotten portion from the butt log. When the rot goes up too high for this, it may be possible to chop or saw around the rot with cornering cuts (2, fig 5-13) similar to those used for leaning trees.

b. When the butt of the tree is badly decayed, it is much safer to chop it down and not use the saw at all. The feller should be more alert than usual

when felling a rotten tree. The direction in which it falls is very difficult to control.

5-13. Handling Lodged Trees

a. Even the most experienced tree feller sometimes lodges a cut tree in a standing one. An exceptionally sturdy limb on either the tree being felled or the one in its way may fail to bend as expected; or the cut tree may fall or twist out of line. The better and more experienced the felling crew, the fewer trees they will lodge. Dislodging may be easy and safe, or it may be very difficult and dangerous, depending on conditions. Cutters must be able to diagnose how firmly a tree is lodged and what method of getting it down is best.

b. If the tree is lightly lodged, cutting it loose from its stump and prying the butt off to the ground may cause the tree to dislodge and fall. Pushing or twisting it loose is the next step, and is frequently used when only the ends of the limbs are caught. Climbing up the inclined trunk of the lodged tree and attempting to shake it loose by jumping up and down is a dangerous procedure, and is not recommended even for the most experienced men.

c. The safest and most practical way to free a lodged tree is to back the logging tractor to within a safe distance from the lodged tree, attach the winch cable around the butt of the lodged tree, and pull the tree down.

Warning: Perhaps the most dangerous practice of all is to cut the tree in which the first one is lodged. In doing this it is difficult to judge the stresses involved, or the way the two trees will fall. If this method becomes necessary, the most experienced and alert man should do the chopping alone. Because he will be in a better position for a getaway than a saw crew. Also, working alone, one man can better judge when and in what direction to run.

5-14. Safety in Felling

a. Before making any cuts in the tree, study it carefully for lean, obstructions to the path of fall, wind effect, rolling effect of trunk colliding with adjacent obstacles during its fall, and center of gravity of the tree.

b. Choose a safe line of retreat from the tree and remove all obstacles which could block the way.

c. Wear some kind of reinforced head gear—if possible, a safety helmet which will protect your head from falling limbs or other objects.

d. Two men should not chop together on a tree of less than 20 inches in diameter.

e. Do not leave a tree which has been started, even at lunch time or at the end of a shift.

f. Before starting to make the cut get steady footing to be sure your feet will not slip.

g. Do not attempt to start a chain saw by holding it in the hand and pulling the starter with the other hand. Place the saw on solid footing and secure it well before attempting to start the motor.

h. The engine and accessories reach high temperatures during operation. Be careful not to touch hot parts. Gloves are a help in case of accidental contact.

i. Do not check the tension of the chain with the engine running.

j. When crews are working several saws in the same area, they should keep a reasonable distance apart. Be sure that warning shouts can be heard by everyone.

k. Do not move the saw from one tree to another while it is running.

l. Watch the fall of the tree and be on guard against limbs of other trees snapping back when hit by the falling tree.

5-15. Fire Prevention Rules for Power Saws

a. Do not smoke while filling gasoline tanks.

b. Use a gasoline can with a spout or use a funnel.

c. Fill the tank only on an area of bare ground.

d. Do not start the engine at the place the tank was filled.

e. Keep the entire saw clean of gasoline, oil and sawdust.

f. Be sure the muffler is in good condition.

g. Keep the muffler in place at all times while the saw is in operation.

h. Keep the spark plugs and wire connections tight.

i. Clear flammable material away from the point of saw cut.

j. Promptly extinguish any fires. Report fires and possible causes of fires to foreman immediately.

CHAPTER 6

LIMBING, BUCKING, AND SCALING

6-1. Introduction

This chapter explains the operation of removing branches from the felled tree (limbing), cutting the tree into log lengths (bucking), and measuring the logs (scaling). It also describes the tools used in these three processes and discusses defects in logs.

6-2. Limbing

a. Description. After the tree is on the ground, the next step is the removal of the limbs. Limbing is usually done with the ax or chain saw. When using the ax, the limbs should be cut from the lower side (cut from the base toward the top of the tree). The stub of the limb should be left even with the tree bark. Trees that have been carelessly limbed are hard to skid and load.

b. Ax Handling. Limbing is like other chopping in most ways. The same grip on the handle and the same swing are used. Much of it does, however, have to be performed in restricted areas and from awkward positions. The variation in size of

limbs calls for good judgement as to the right amount of force to be put behind the swing of the ax. There is a much greater chance of accident from an ax swung amidst branches than from an ax used in clear chopping, so the axman should clear away any branches that are likely to interfere with chopping. Wherever possible the axman should cut limbs on the opposite side of the log and swing the ax away from himself (fig 6-1). The inexperienced chopper should not do any limbing while standing on the tree trunk. As he gains experience and learns to control his ax, he will be able to work safely in positions hazardous for the inexperienced.

c. Large Limbs.

(1) For large limbs, particularly on hardwoods, it is often necessary to cut a notch similar to that used in cutting down a tree (fig 6-2). The limb is cut from the lower side, as always, and the bottom surface is kept even with the trunk surface.

(2) The vertical side of the notch should slope somewhat with the angle of the limb. Often a large notch is easier to cut than a small one. The downward cut is made with the grain of the wood and not directly across it. Chopping should be done lightly at an angle, or with the grain, and there should be no attempt to twist out the chips. Larger limbs on hardwoods are usually easier to saw off than to chop off.

RIGHT POSITION

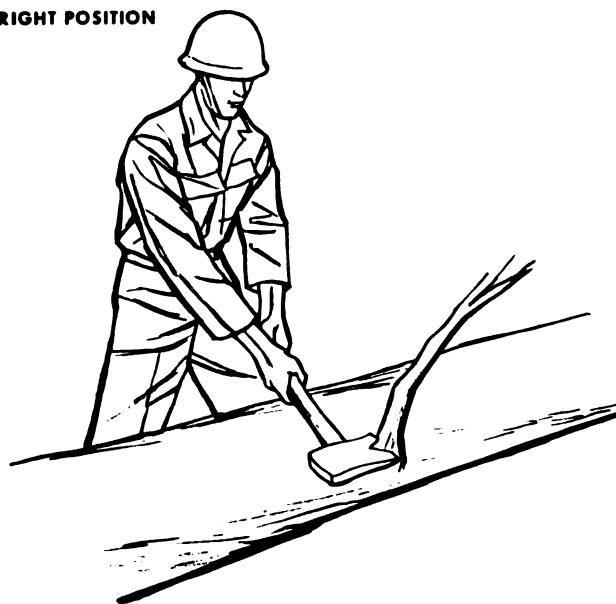
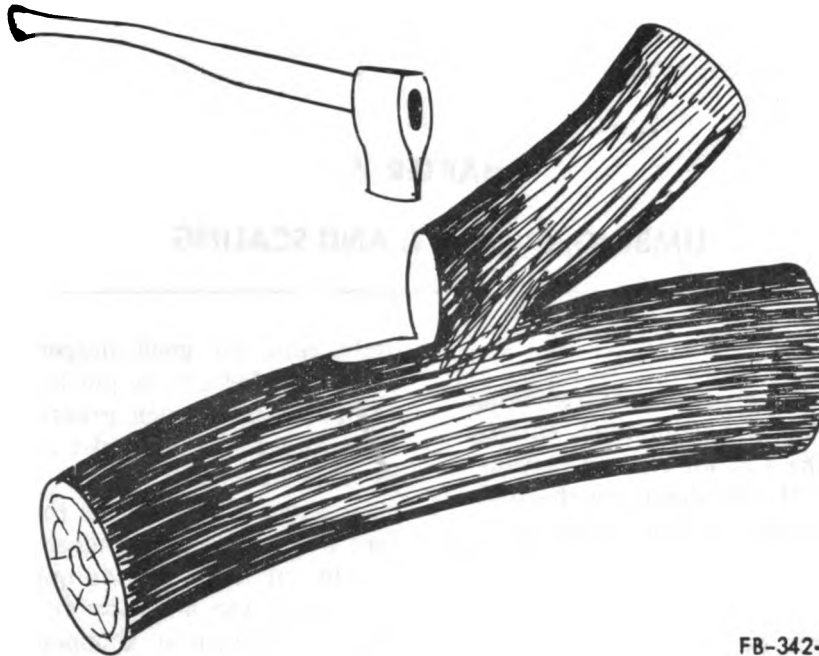

Figure 6-1. Safe position for limbing.

6-3. Bucking

As woods operations have become more mechanized, the bucking operation (cutting the tree into log lengths) has been shifting from the stump location to the loading dock, or even to the sawmill. There is economy in handling long logs or tree length timber when the quantity to be handled justifies the use of heavy equipment for skidding, loading, and hauling. There is another advantage in bucking at the landing or in the mill yard. Semiportable power saws become feasible; logs can be cut to more accurate lengths. A buck-



FB-342-39

Figure 6-2. Cutting off a large limb.

ing crew that does nothing else will develop maximum skill in cutting the quality logs, especially out of hardwood trees.

6-4. Log Grades

a. Wherever the logs are bucked, the leader of the bucking crew must be familiar with the log grading system used for the species being cut. All grading systems are based on the grade of lumber that can be sawed from the log. Logs suitable for sawing must meet the minimum standards of length, diameter, quality, and species. Factors influencing lumber grades are covered in TM

715-5500-1. For practical purposes in bucking felled trees, the lead buckler should set up a grade of standards similar to that shown in table 6-1. For timber that is to be used for piling or other uses requiring long lengths, a separate table may be necessary.

b. The United States maintains the highest grading standards of any nation. In overseas operations it may be necessary to adjust grade standards to the standards which are in use in the area being logged. This will be particularly true if the timber is being purchased from private interests.

Table 6-1. Typical Log Grading System

Log grade	Small end diameter	Requirements	Description
No. 1 (good)-----	Over 10"-----	All lumber cut from this log must be No. 1 Common or better.	Surface and ends clear of defect, and sapwood bright in color. Two small limb knots are allowed, but two large knots on body knots make it a No. 2 grade. If the knots occur at each end it is a cull log.
No. 2 (common)-----	Min 6"-----	Two-thirds of the lumber cut from this log must be No. 1 Common or better.	Must not have more than three standard defects (note), or be only slightly wormy.
No. 3 (cull)-----		One-half of the lumber cut from this log must be No. 2 Common with a little of the better grades.	More than two limb or body knots. Some worm and knot defects.

NOTE. (1) Standard defects are—knots, rot, shakes, season checks, frost cracks, sun, scald, fire scars, seams, wormholes, stain, spiral or crooked grain, cat faces, and crook in the log. Most exterior checking and shallow cat faces are not defects, since they go into the slab only.
 (2) No. 1 Common— $\frac{3}{4}$ of the surface of the board is clear faced.
 (3) No. 2 Common— $\frac{1}{2}$ of the surface of the board is clear faced.

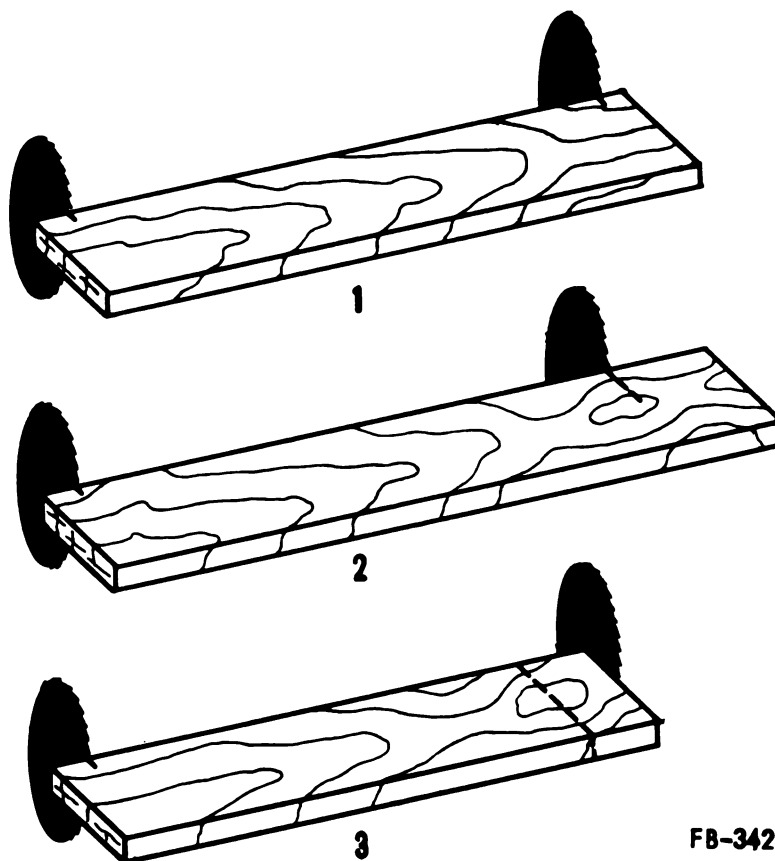

FB-342-40

- 1 Right length allows just enough for trimming.
- 2 Extra length causes waste in trimming.
- 3 Too short for trimming, will be cut to next shorter standard length.

Figure 6-3. Trimming.

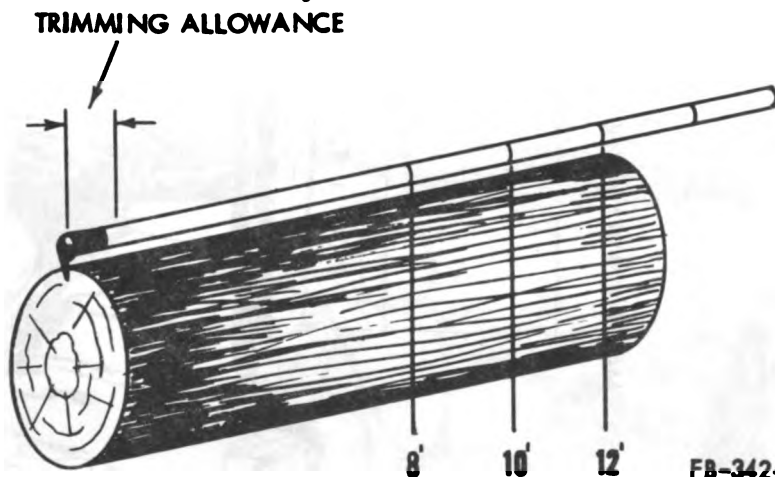

FB-342-41

Figure 6-4. A log measuring pole.

6-5. Log Lengths

a. Saw logs are ordinarily cut in lengths from 8 to 16 feet by 2-foot intervals. Increasingly, as materials become more scarce, the demand is greater for the highest quality logs in the 8- to 16-foot group. However, where special types of construction are being undertaken, specifications fre-

quently call for 20-, 24-, and even 32-foot material. Therefore, good judgment in dividing the tree into logs and a knowledge of the specification requirements cannot be overemphasized. Accuracy is also important. Ordinarily, a 2-inch trimming allowance for each 16-foot or shorter length is specified in order that any irregularity in the ends

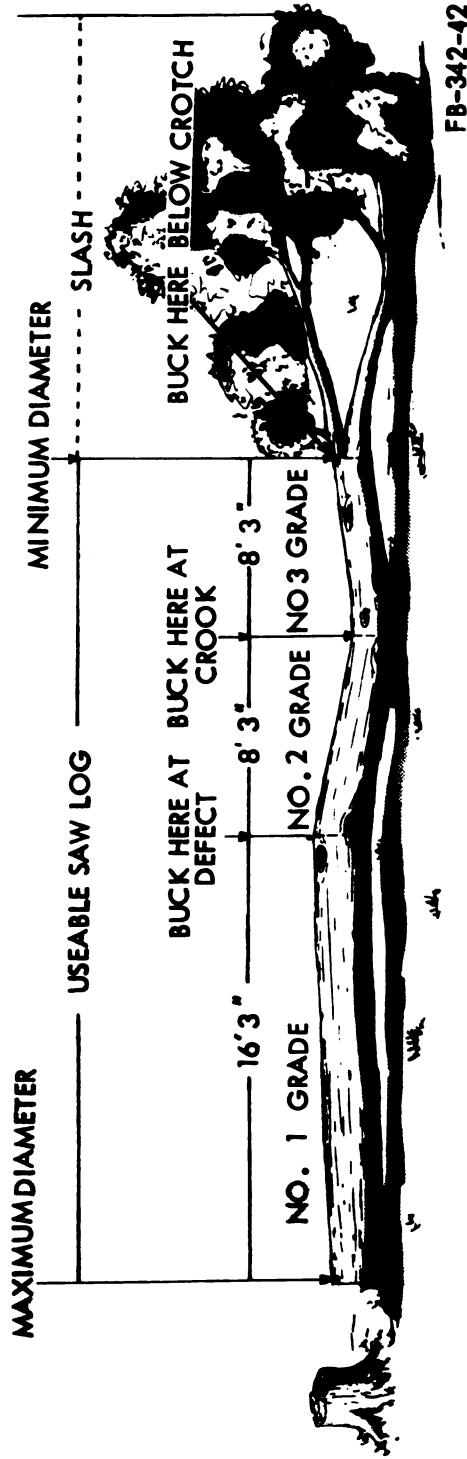

Figure 6-5. Log bucking plan.

can be evened off by the trim saws at the mill (1, fig 6-3), leaving square-end boards of the full specified length. Logs with a greater allowance are penalty scaled for unnecessary wastage (2, fig 6-3). Logs failing to have this allowance are scaled in the next lower allowable length (3, fig 6-3).

b. An accurate log measuring pole (fig 6-4) that shows the specified trimming allowance at the butt should be used. The person marking a log should guard against shortening the pole by chopping off its end. A metal hook on the butt end of the pole is often an aid to its more accurate use.

6-6. Bucking Procedures

The first step in bucking saw logs is to measure the total usable length of the tree (fig 6-5). This total should be subdivided into the individual log lengths in a way that will obtain both maximum

scale and grade. This is done before the crew starts to buck. The following suggestions will aid in obtaining maximum scale and grade.

a. Sawcuts made below large limbs generally give larger scale in the butt log, since the knots are not included.

b. Wherever possible, surface defects should be kept in the butt portions of logs, where they will be trimmed off in slabs.

c. Defects should be grouped in one log if possible. This often means sawing knots, rotten areas, and so on, which is contrary to the natural inclination of the sawyers, but it raises the grade of the product.

d. Sawing too close to the base of a crotch and showing a double heart on the small end of the log should be avoided.

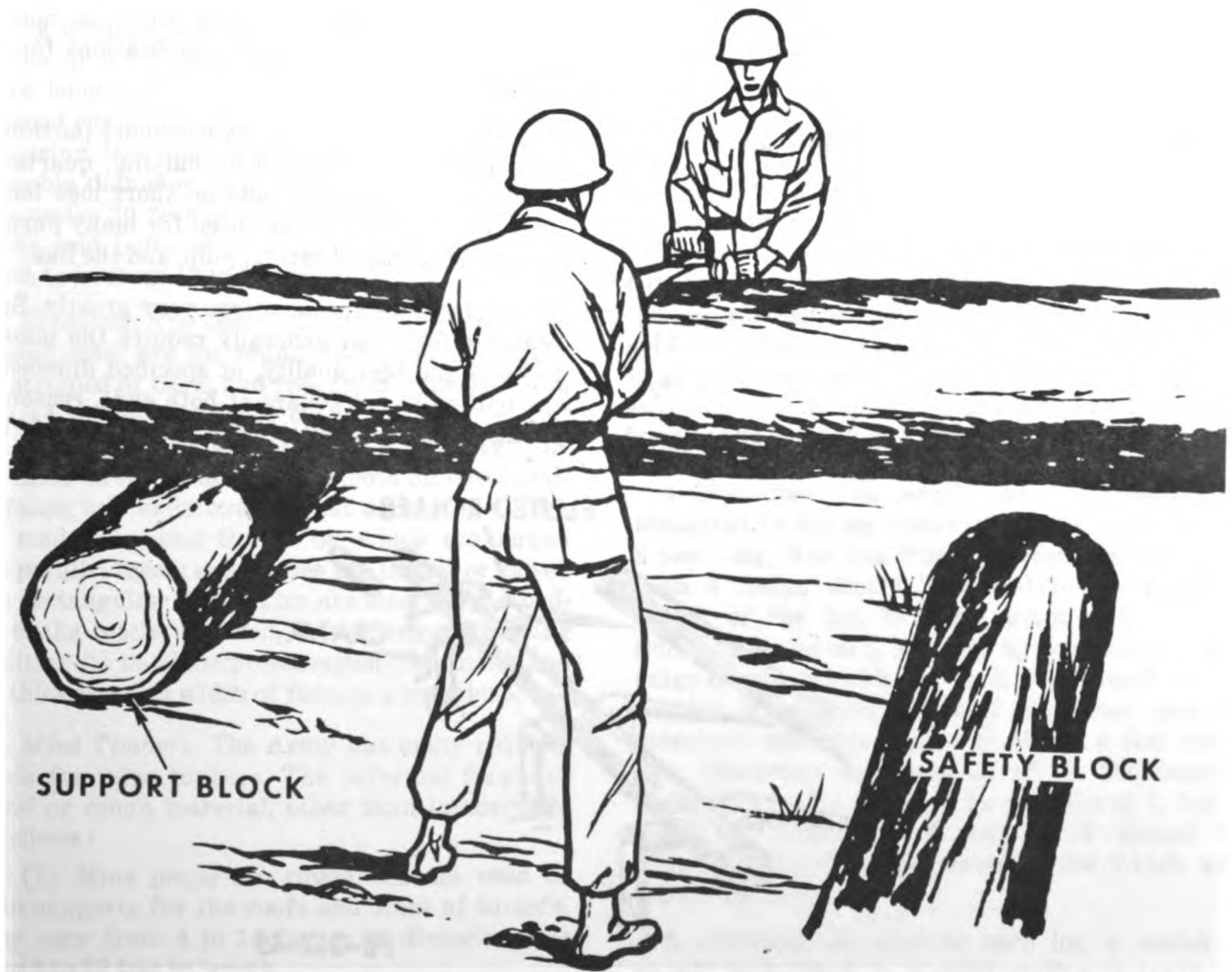

Figure 6-6. Method of propping and bucking a log.

e. If practicable, cuts should be made at points of the most abrupt crook, leaving the cut logs as straight as possible.

f. Wedges should be used frequently in bucking to prevent pinching the saw. The crew will ordinarily carry two or three wedges and a maul to drive them.

g. Before starting to buck, all brush or trash on either side of the log should be cleaned out to get space to work.

h. Because of the weight of the logs, blocks (fig 6-6) should be placed alongside the truck to keep the cutoff section from dropping or rolling on one of the buckers, especially when working on a hillside or sloping ground.

i. Blocking used under the trunk prevents the log from splitting with a consequent loss of valuable material.

j. Sometimes, when a heavy trunk is suspended from the two ends, it is necessary to make part of the cut from underneath. This is a more difficult operation because either the power saw or cross-cut saw will have to be held into the cut.

6-7. Use of Mechanical Equipment

The use of mechanical equipment, such as the tractor, the logging arch, and the grapple has increased the amount of logs that are delivered per hour to the log yard. This, in turn, overloads the bucking crew and necessitates the use of mechanical equipment to facilitate bucking. Bucking skids and chutes are constructed to ease the handling of logs and to avoid the pinching of the saw. The mechanical bucking chute (fig 6-7) is either hand

or motor operated. It has a series of concave rollers with the front roller fluted or spiked. This roller is rotated (crank or motor) to advance the log for each succeeding cut. The bucking chute also supports the log and thus prevents pinching of the saw. Some mills construct motorized bucking plants which take tree-length logs. These mills, with circular saws, are often set up at the logging site. Some saws are pushed or pulled into the log by a hand lever; others are swung into the log mechanically. This mechanized equipment may be assembled from spare parts and various excess equipment the forestry team has access to.

6-8. Log Classifying

The most important function of the military log scaler is that of classifying uncut logs. He judges the quality of the log, determines its eventual use, and marks it, accordingly, for bucking. If the timber is purchased by the log, his job will include measuring the logs for board- or cubic-foot content. The forestry team is responsible for supplying a great variety of timber products. Some of the more common uses and specifications for timber are listed below.

a. *Bolts and Billets.* Bolts are short portions of logs. Billets are obtained by halving, quartering, or otherwise splitting bolts or short logs lengthwise. Bolts and billets are used for many purposes such as cooperage, crating, pulp, and the like.

b. *Poles.* Pole specifications vary greatly. Specifications for poles generally require the material to be of the best quality, of specified dimensions, the butt to be cut square at both ends, reasonably straight, well proportioned from top to butt,

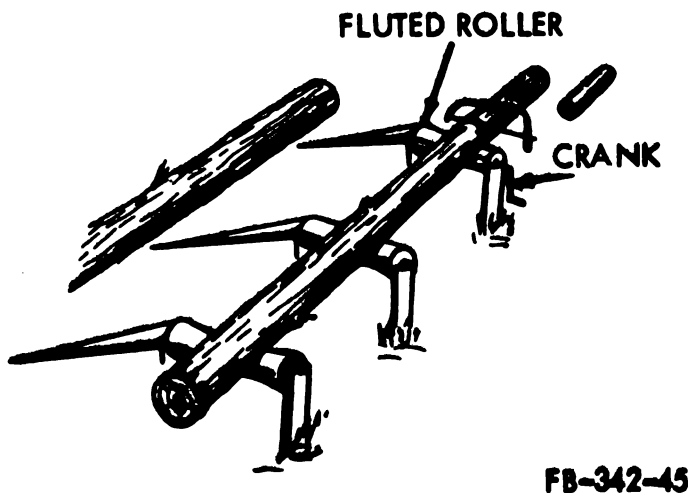

Figure 6-7. Mechanical bucking chute.

peeled, and with knots trimmed close. Defects looked for in inspection are crookedness, split tops, split butts, sap and butt rot, checks, and shakes. (Defects will be discussed in detail later in this chapter.)

c. Piling. The classification and grading of piling depends largely upon its use, whether in fresh water or salt water or on land, and upon its form and size. Very often the kind of wood is not specified, and the requirements refer to straightness, length, and butt diameter measurement 3 feet from the end. Important construction work often calls for specifications similar to the following: All piling shall be cut from sound, live trees of slow growth and firm grain and free from ring heart, wind shakes, decay, large or unsound knots, or any other defects that will impair their strength or durability. The trees shall taper uniformly from butt to tip. Piles shall be so straight that the line joining the centers of the ends will fall entirely within the pile and that, in the opinion of the inspector, they can be subjected to hard driving without injury. No short or reverse bends will be allowed. Bark shall be peeled from the entire length of all piles, and all knots shall be trimmed close. No pile will be accepted with a top measuring less than 6 inches in diameter. The allowable diameter shall be as follows: Butts of piles under 30 feet in length to be from 12 to 16 inches, and butts of piles from 30 to 50 feet in length to be from 12 to 18 inches.

d. Crossties. The specifications for railroad ties in most cases are for sound timber of good quality, stripped of bark, and free from imperfections, such as shakes and loose or decayed knots, that would impair their strength and durability. The ties must be sawed or hewed smooth on two parallel faces, and ends must be cut square. Pole ties are made of round timber on which are hewed two parallel faces; square ties are hewed or sawed into rectangular shape. Ties are classified according to the species of wood, its wearing and lasting qualities, its need for preservation treatment, and the thickness and width of face, or dimensions.

e. Mine Timbers. The Army has many requirements for mine timbers. The principal forms of round or rough material, other than lumber, are as follows:

(1) Mine props are round timbers used as main supports for the roofs and sides of tunnels. They vary from 4 to 14 inches in diameter, and from 3 to 12 feet in length.

(2) Caps are hewed or sawed pieces of tim-

ber of different sizes laid across the tops of pairs of props to support the roof lagging which runs lengthwise along the tunnel.

(3) Lagging is round timber about 3 inches in diameter and 7 feet in length, used to fill in behind the props and caps to form the sides and roofing of the tunnels. Bars are extra long lagging.

(4) Sills as foundation for props are from 8 to 14 inches in diameter. Although these are often of sawed material, square hewed timbers are often used.

(5) Mine ties, including tramroad, motor, and heading ties, are ordinary track ties, 4 inches on the face and varying in length mostly from 3 to 5 feet.

(6) Rough lumber goes into mine rails, collar timbers, brattice or partition boards, stringers, and sills.

f. Cordwood. Any kind of wood measured by the cord and in the form of either round or split sticks is called cordwood. Firewood is measured in standard cords, mostly 4-foot lengths, or short cords of stove wood and other material varying from 12 to 20 inches in length. Wood which is to be used for distillation, extract wood, excelsior, pulp wood, handles, cooperage, and woodenware is frequently sold by the rick or cord. The lengths vary mostly from 22 inches for heading and from 5 feet for extract and handle stock. Specifications, if given, refer to the kind of wood, length, average size of the pieces, whether split or round, general soundness, body or limb wood, and degree of dryness.

6-9. Log Scaling

a. Procedure. Log lengths can be conveniently measured by the log scaler with a measuring stick 8 feet long. Not less than 2 inches and not more than 6 inches should be added to the nominal length of the log, so that rough ends can be trimmed at the mill. For scaling purposes the average diameter inside the bark at the small end of the log is measured. Several diameters may be measured where necessary to obtain a fair average. Diameters are rounded off to the nearest inch; that is, 7-1/4 would be considered 7, 7-3/4 would be considered 8, and 7-1/2 should be roughly divided equally between the 7-inch and 8-inch diameters.

b. Marking. As soon as each log is scaled it should be marked to prevent scaling it again. If systematic scaling is done, it is desirable to use a

LOG NO.	LENGTH	DIAMETER	SCALE	LOG NO.	LENGTH	DIAMETER	SCALE
	FEET	INCHES	BD. FT.		FEET	INCHES	BD. FT.
1				12			
2				13			
3				14			
4				15			
5				16			
6				17			
7				18			
8				19			
9				20			
10				21			
11				22			

FB-342-46

Figure 6-8. Sample form for a log scale book.

special book for this purpose (fig 6-8). Each log is recorded in the book. When the log is scaled its number is written on the small end of the log.

c. *Scale Book.* The scale book (fig 6-8) should be ruled off into groups of four columns, the first column for the number of the log, the second for its length, the third for its diameter, and the fourth for the number of board feet. Only one grade of timber (table 6-1) should be entered on a page.

d. *Log Rules.* Either the Scribner decimal C log rule or the international Scale log rule (fig 6-9) is used by the log scaler to determine the number of board feet in a log. The scale stick is 48 inches long and calibrated to show the board-foot contents of logs up to 48 inches in diameter. The international log rule is discussed in paragraph 6-23 and the use of the Scribner decimal C rule is explained in paragraph 6-10.

6-10. Scaling Logs in Board Feet by Scribner Decimal C Rule

a. Scaling is subject to many small differences in practice in different regions and by different organizations. The most uniform and widely used system of scaling is that practiced by the United

States Forest Service. This system forms an excellent guide to those just beginning to learn scaling. On practically all of its sales of saw timber, the Forest Service scales its logs by the Scribner decimal C log rule (table 2-4).

b. The maximum and minimum scaling lengths are usually set for each timber cutting operation. Logs longer than the minimum scaling length are scaled in 2-foot increments. Instead of taking the nearest 2 feet, the logs are scaled to the nearest even 2 feet below the actual length. A trimming allowance of 3 inches (for cutting the log off square at the mill and cutting off ends broomed or filled with grit in skidding) is allowed over scaling length. Too large a trimming allowance is corrected by scaling the log to the next longest 2 feet. Ordinarily, all logs over 16 feet are scaled as two or more logs of as nearly the same length as practical. Lengths of either 16 feet or 12 feet are preferable when dividing a long log for scaling.

c. The length of the log is measured with a tape. The average diameter of the log (inside the bark) at the small end is measured in inches with a scale stick or a ruler (2, fig 6-9). The scale stick shows diameter in inches on one edge and above it the board foot volume, in tens, by the Scribner deci-

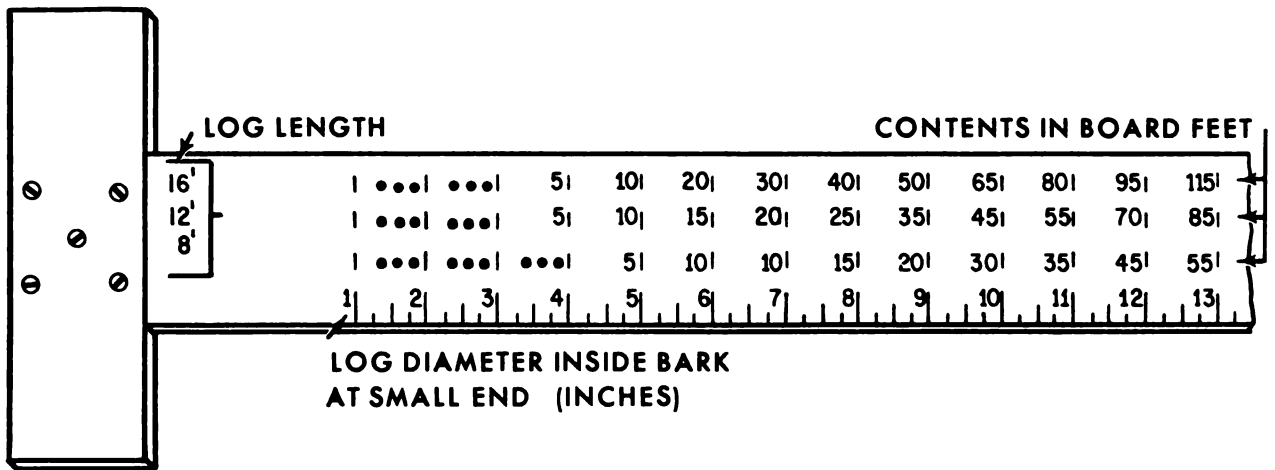

1 INTERNATIONAL SCALE LOG RULE

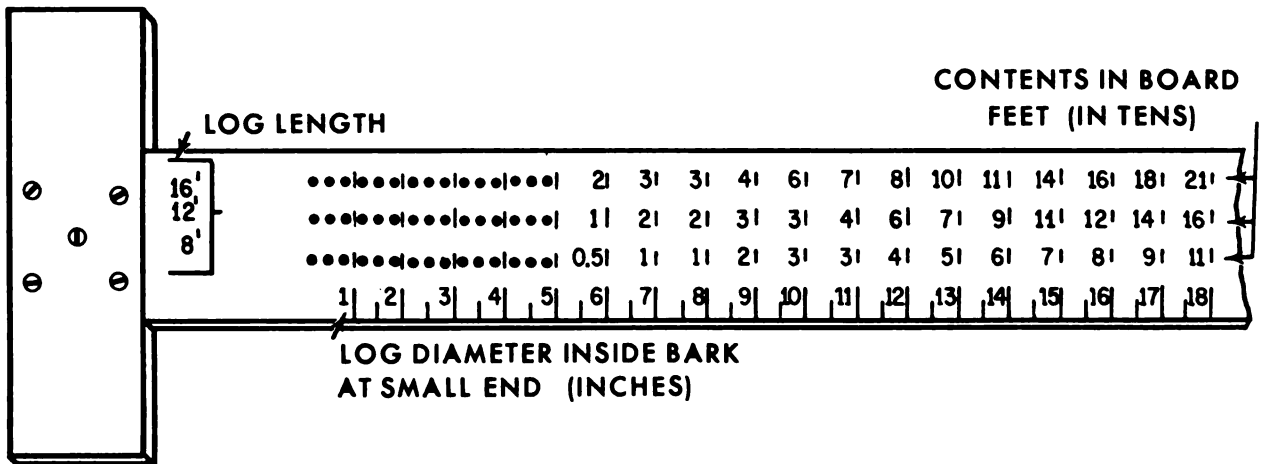

2 SCRIBNER DECIMAL C LOG RULE

Figure 6-9. Examples of log rules.

mal C rule, for that diameter of different lengths. Except where the small end of the log is perfectly round, the diameter (inside the bark) is measured the longest and the shortest way, and the average diameter to the nearest inch is used. Thus, if the diameter (inside the bark) at the small end is 18.5 inches the long way and 16 inches the short way, the average is 17.2 inches and the log would be called a 17-inch log.

d. For inexperienced scalers, the best rule is to assume even taper on all except butt logs. Thus a log 40 feet in length, 16 inches in diameter at the small end and 21 inches in diameter at the large end might be scaled as—a 16-inch log, 12 feet long, a 17-inch log, 12 feet long, and a 19-inch log, 12 feet long. This was figured as follows: total taper in 40 feet equals $21 - 16 = 5$ inches; if the log has even taper this amounts to $1/2$ inch per 4 feet. The top diameter of the first 12-foot

length is the top diameter of the log (16 inches). The top diameter of the next 12-foot log is 16 inches plus $(3 \times 1/2) = 17-1/2$ inches, rounded off to 17 inches. The top diameter of the remaining 16-foot length is $17-1/2$ inches plus $(3 \times 1/2) = 19$ inches. For butt logs, inexperienced scalers should use taper tables. In some operations, odd-length lumber can be used. Under these conditions, logs will be scaled to the nearest whole foot in length below the actual length rather than to the nearest even foot.

6-11. Deductions for Defect Board Feet, Using Scribner C Rule

a. *Amount of Deduction.* The Scribner C rule is measured from the diameter of the small end of the log inside bark and allows for boards 1 inch thick with a saw kerf (width of cut made by a

saw) of 1/4 inch between boards. No allowance is made for taper, and in the tables a certain amount of solid wood around the edges is allowed for slabbing (removing the outer surface of a log in order to obtain a flat surface for sawing lumber). In allowing for defects, therefore, any part of the defect falling in the slabs already deducted by the rule, or in the saw kerf already deducted by the rule, should not be deducted again in scaling. When the defect is in the center of the log, the deduction is reduced by the amount of saw kerf only. When the defect comes in from the surface of the log, the deduction is reduced by the amount of taper and slabs, as well as by the amount of saw kerf.

b. *Right Cylinder.* The Scribner rule treats the log as a right cylinder whose diameter is equal to the average diameter (inside the bark) at the small end of the log, and whose length is the

scaled length of the log. A right cylinder is a cylinder whose ends are perpendicular to the length. All defects outside the right cylinder of the log are disregarded, since no wood outside the right cylinder has been included in the gross scale of the log as given by the rule. In addition, a certain amount of slabbing has been omitted from the gross scale by the rule. The amount varies with the size of the log, but in allowing for defect it is assumed that it is equivalent to a collar 1 inch thick just inside the edge of the right cylinder. This is illustrated in 9 and 11, figure 6-10.

c. *Standard Rule.* The standard rule for allowing for defects within the right cylinder and within the inside edge of the slab collar is—deduction = $\frac{a \times b \times L}{15}$, in which *a* is the depth or thickness of the defect, in inches; *b* is the width of the defect, in inches; and *L* is the length of the

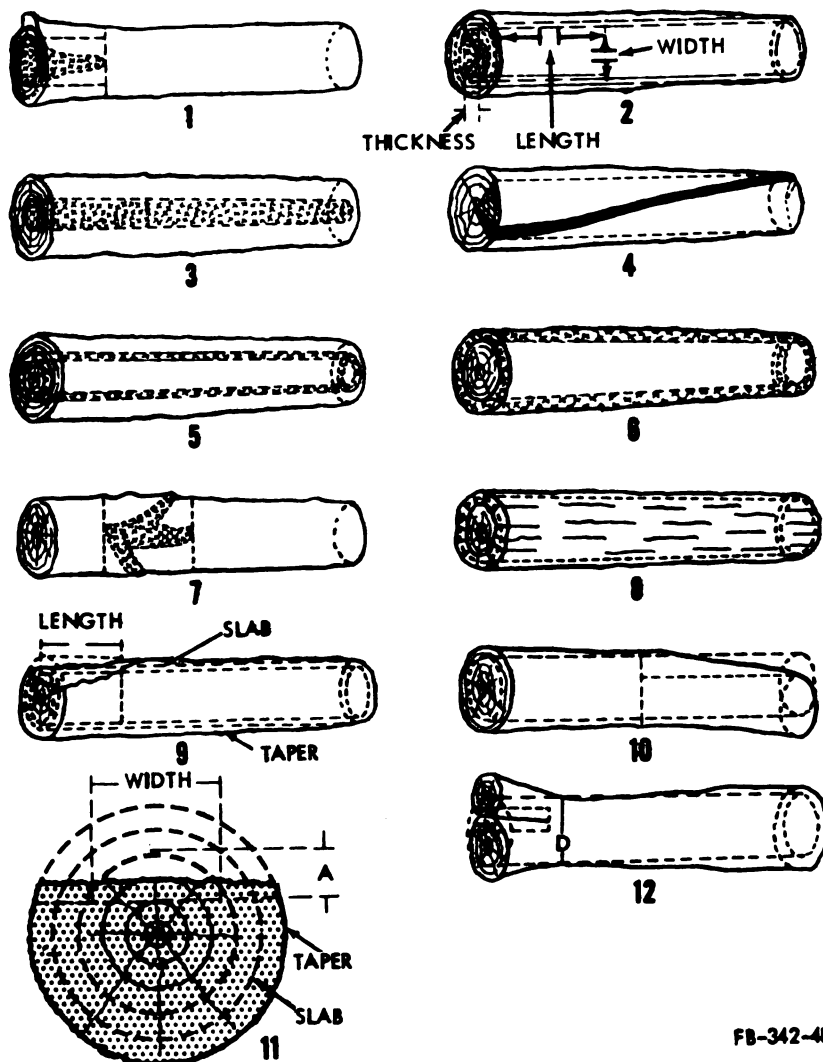

- | | |
|-----------------|----------------|
| 1 Stump rot | 7 Rotten knots |
| 2 Heart check | 8 Wind checks |
| 3 Circular rot | 9 Fire scar |
| 4 Frost check | 10 Crook |
| 5 Ring shake | 11 Fire scar |
| 6 Punky sapwood | 12 Crotch |

FB-342-48

Figure 6-10. Defects in logs.

defect, in feet. This deduction is in board feet and must be divided by 10 to obtain tens of board feet corresponding to values given by the Scribner decimal C log rule. It will be noted that the divisor in the rule is 15 instead of 12. This reduces by 20 percent the amount already deducted in the rule for saw kerf. In the case of circular defects in the center of the log, a and b are equal and become D^2 in the formula for deduction. It is customary to add an inch to the actual thickness and width of the defect to allow for sawing around it. The standard rule might be written—

for circular defects, taking out a square piece,

$$\text{deduction} = \frac{(D + 1)^2 \times L}{15}$$

for defects taking out a rectangular piece,

$$\text{deduction} = \frac{(a + 1)(b + 1)L}{15}$$

in which D is the actual average diameter of the circular defect in inches; a is the actual thickness of the rectangular defect in inches; b is the actual average width of the defect in inches; and L is the length of the defect in feet.

d. Cull Logs. The amount of defect in a log necessary to cause its rejection as a cull log (a log of merchantable size but rejected because of defects) varies in different localities and usually is specified for each timber cutting operation. In general, logs of a valuable species in which less than 33 percent of the gross scale (read from scale stick or log table) is merchantable are considered cull logs, whereas logs of less valuable species in which less than 50 percent of the gross scale is merchantable are considered cull logs.

6-12. Common Defects

The common defects for which deductions are made may be grouped into interior defects, including stump rot, circular rot, ring shake, pitch ring and heart check; side defects, including fire scar, frost check, punky or broken down sapwood, and wind checks; and form defects, such as crook or sweep, and crotch. These defects are illustrated in figure 6-10, and described in paragraphs 6-12 through 6-21. No deductions are made for seams, stains, scalds, and sun damage (table 6-1).

6-13. Rot

a. Stump Rot.

(1) Stump rot is found only in butt logs and is illustrated by 1, figure 6-10. The figure shows a

log 12 inches in diameter (inside of bark) at the small end and 16 feet long. It has a stump rot with an average diameter of 8 inches at the butt end of the log, estimated to extend 4 feet up the log. By the standard rule the deduction would be—

$$\frac{(8 + 1)^2 \times 4}{15} = 22 \text{ board feet, or rounded off to the nearest ten, 2.}$$

The gross scale of a 12-inch, 16-foot log is 8 (from table 2-4). The net scale would be $8 - 2 = 6$, or 60 board feet.

(2) Another method of deducting for stump rot is to reduce the length of the log by the length of the rot. In this instance, the net scale might have been found by looking up the volume of a 12-inch, 12-foot log ($16 - 4 = 12$). The rule shows 6, or 60 board feet, for such a log. The customary practice is to use whichever method will give the smaller deduction. In this instance it made no difference. Had the average diameter of the rot been 9 inches instead of 8 inches, the deduction by the standard rule would have been 26 board feet, or 3, giving a net scale of only 5, or 50 board feet. In that case the log would have been scaled as a 12-inch, 12-foot log and the net scale would be 60 board feet as before. On the other hand, if the average diameter of the rot had been 6 inches instead of 8 inches, the deduction by the standard rule would have been 13 board feet, or 1, giving a net scale of 7 or 70 board feet. Under such conditions the standard rule would be used in scaling.

b. Circular Rot.

(1) Circular rot may appear at only one or at both ends of the log. If it appears at only one end of the log, the diameter is taken at that end and the length it extends up the log is estimated. The deduction is made exactly the same as that for stump rot, unless it is estimated that the rot extends so far up the log that the remaining sound length is below the minimum length of merchantable board. In this case, the length of the log is used as the length of the rot. Ordinarily, this minimum length of board is 6 feet, but in some sections 6-foot boards are not merchantable.

(2) Figure 6-10(3) illustrates a log with a circular heart rot showing at both ends. The log is 12 inches in diameter (inside the bark) at the small end and is 16 feet long. Its gross scale is 8, or 80 board feet. The defect is 4 inches in diameter at the small end and 6 inches in diameter at the large end. For logs 16 feet in length, or

shorter, the diameter of the rot is measured at the large end. By the standard rule the deduction is—

$$\frac{(6 + 1)^2 \times 16}{15} = 52 \text{ board feet, or rounded off to the nearest ten, 5.}$$

The net scale would be: $8 - 5 = 3$, or 30 board feet. If cull logs are all those whose net scale is less than 50 percent of the gross scale, this log would be cull. If cull logs are those whose net scale is less than 33 percent of the gross scale, this log would be acceptable.

(3) If, in a region where logs longer than 16 feet are scaled as one log, the length of the log in 3, figure 6-10, is 18 feet and all other dimensions are the same, the average of the diameters of the defect at the two ends would be used instead of the diameter at the large end. This is the customary practice for logs longer than 16 feet in regions where such logs are scaled as one log. The average diameter of the defect at the two ends would be the average of 6 and 4, or 5 inches. The deduction by the standard rule would be—

$$\frac{(5 + 1)^2 \times 18}{15} = 43 \text{ board feet, or rounded off to the nearest ten, 4.}$$

The gross scale of a 12-inch, 18-foot log is 9, or 90 board feet. The net scale of the log would be: $9 - 4 = 5$, or 50 board feet. The log would be more than 50 percent sound and would, therefore, be acceptable.

(4) In some localities logs longer than 16 feet are scaled as two or more logs. If the length of the log in 3, figure 6-10 is 18 feet, it is scaled as a 10-foot log and an 8-foot log and the taper would be calculated on the entire length of the log, including the defective part. The diameter (inside the bark) at the small end of the log is 12 inches and the diameter (inside the bark) at the large end is 16 inches. The total taper is: $16 - 12 = 4$ inches for the 18-foot length. This amounts to 0.22 inches per foot or 1.8 inches in 8 feet. Without the defect, the diameter (inside the bark) at the top of the first 8-foot length would have been the diameter of the log, or 12 inches; the diameter (inside the bark) of the 10-foot length would be $12 + 1.8 = 13.8$, or 14 inches. The diameter of the defect at the small end is 4 inches and 6 inches at the large end. The taper in the defect is 2 inches in 18 feet or 0.11 inch per foot or 0.88 inch in 8 feet. The diameter of the defect at the large end of the first 8-foot length would be $4 + 0.9 = 4.9$ or 5 inches; the diameter of the defect at the large end of the 10-foot length is the same as the diameter of the defect at

the large end of the log or 6 inches. Applied to the 8-foot length, the standard rule gives a deduction of—

$$\frac{(5 + 1)^2 \times 8}{15} = 19 \text{ board feet, or rounded off to the nearest ten, 2.}$$

(5) The gross scale of a 12-inch, 8-foot log is 4, or 40 board feet. The net scale of the 8-foot length would be $4 - 2 = 2$, or 20 board feet. Applied to the 10-foot length, the standard rule gives a deduction of—

$$\frac{(6 + 1)^2 \times 10}{15} = 33 \text{ board feet, or rounded off to the nearest ten, 3.}$$

(6) The gross scale of a 14-inch, 10-foot log is 7, or 70 board feet. The net scale of the 10-foot length would be: $7 - 3 = 4$, or 40 board feet. The net scale of the whole log would be: $2 + 4 = 6$, or 60 board feet. The log would be acceptable.

6-14. Ring Shake

a. Ring shake (5, fig 6-10) is the separation of the layers of wood along the annual rings. It may run only part of the length of the log or it may appear at both ends. It is treated exactly in the same way as a circular rot and deductions are made by the standard rule. Sometimes, however, there is a core of sound wood in the center of the shake which is large enough to be scaled as a merchantable log. In this case, the amount of deduction by the standard rule is reduced by the scale of this core. For example, the log is 12 inches in diameter (inside the bark) at the small end, 16 inches in diameter (inside the bark) at the large end, and 16 feet long. The shake is 7 inches in diameter at the small end and 8 inches in diameter at the large end and extends the full length of the log.

b. There is a solid core in the center of the shake 6 inches in diameter at the small end of the log. The deduction by the standard rule is—

$$\frac{(8 + 1)^2 \times 16}{15} = 86 \text{ board feet, or rounded off to the nearest ten, 9.}$$

The scale of a 6-inch, 16-foot log is 2, or 20 board feet. The net deduction for defect would then be: $9 - 2 = 7$. The gross scale of a 12-inch, 16-foot log is 8, or 80 board feet. The net scale of the log is: $8 - 7 = 1$, or 10 board feet. In this particular case the volume of the core is the true net volume of the log since the deduction by the standard rule is greater than the gross scale of the core. This log, however, would still be a cull.

c. A pitch ring, which is a heavy deposit of pitch along an annual ring or group of annual rings, is treated in the same way as shake if the deposit is heavy enough to be a defect.

6-15. Rotten Knots

Two or more rotten knots on opposite sides of the log and within an area of 2 linear feet are sufficient evidence that there is a limited amount of rot in the log even though the rot does not appear at either end of the log. The best background the scaler can have when allowing for such a defect is a knowledge of how different species of logs in the region showing this evidence of rot saw out in the mill. Where such knowledge is lacking, it is safe to assume that the rot runs down the stem to a point at least 1 foot below the lowest rotten knot and up the log to a point at least 1 foot above the highest rotten knot. This type of defect is illustrated in (7, fig 6-10), which shows a log 12 inches in diameter (inside bark) at the small end and 16 feet long, and with a rotten knot 7 feet from the large end. The deduction is made by reducing the scale by the estimated length of the affected section. Allowing 1 foot below the lowest knot, the rot is estimated to extend within 3 feet of the large end. Allowing 1 foot above the highest knot, the rot is estimated to extend 8 feet from the large end or 8 feet from the small end. Since boards less than 6 feet in length are not merchantable, the sound wood below the rot cannot be included in the net scale. The length of the log must be reduced by 8 feet; therefore, the net scale of the log will be the scale of a 12-inch, 8-foot long log, which is 4, or 40 board feet. The gross scale of a 12-inch, 16-foot log is 8, or 80 board feet; hence, the log is acceptable.

6-16. Heart Check

Heart check, illustrated in 2, figure 6-10, is deducted as a rectangle by the standard rule. Of course, if the log has spiral grain and the heart check is thereby twisted in the log, the size of the rectangle must be proportionately larger. This general principle is illustrated in connection with frost check in (4), figure 6-10. When the heart check appears at only one end of the log, the distance it extends into the log must be estimated. In applying the standard rule to heart check, *a*, the thickness of the rectangle, and *b*, the width of the rectangle, must be entirely within the right cylinder and the slab. It will be noticed in 2, figure 6-10 that the part of the heart check extending

beyond the right cylinder and slab at the top of the log is disregarded in determining the dimensions of the rectangle, *a* and *b*. A log 12 inches in diameter (inside the bark) at the small end, and 16 inches in diameter (inside the bark) at the large end, is shown in 2, figure 2-10. The heart check at the large end is 3 inches thick within the right cylinder and slab and 9 inches wide within the right cylinder and slab and is estimated to extend 7 feet up the log. The deduction by the standard rule is—

$$\frac{3 \times 9 \times 7}{15} = 13 \text{ board feet, or rounded off to the nearest ten, 1.}$$

The gross scale of a 12-inch, 16-foot log is 8, or 80 board feet. The net scale of the log is: $8 - 1 = 7$, or 70 board feet. In regions where off-length boards are unmerchantable, the length of the defect would have been taken as 8 feet and the deduction would have been 14 board feet, or rounded off to the nearest ten, 1. The net scale would have been 7, or 70 board feet in that distance.

6-17. Fire Scar

a. The fire scar type of defect, caused by fire damage to the tree, is illustrated in the log shown in 9 and 11, figure 6-10. The common method of allowing for this defect is to divide the log in sections and estimate the proportion of loss in the section affected. The diameter (inside the bark) at the small end of the log in (9), figure 6-10 is 12 inches; the length of the log is 16 feet; the depth of the fire scar at the large end is 6 inches and it extends up the log for a distance of 5 feet. Within the right cylinder and slab, the length of the scar is only 4 feet and the depth of the scar is 3 inches (taper 4 inches in diameter or 2 inches in radius, slab 1 inch in radius; depth of scar $6 - 2 - 1 = 3$ inches). The log is divided into 4-foot sections (length of scar inside right cylinder and slab) and the scale volume of each 12-inch, 4-foot section is 2, or 20 board feet. It is estimated that this scar takes up between $1/4$ and $1/2$ of the total volume of the 4-foot section affected. Assuming $1/3$ of the volume of the section is lost in sawing around the defect, the deduction would be $1/3$ of 20 or 7 board feet, or rounded off to the nearest ten, 1. The gross scale of a 12-inch, 16-foot log is 8, or 80 board feet. The net scale of the log is $8 - 1 = 7$, or 70 board feet.

b. The deduction for fire scar may also be made by the standard rule. In the log 9 and 11 1, figure 6-10, the length of the scar within the right cylinder

der and the slab is 4 feet; a , the depth of the scar within the right cylinder, is 3 inches (6 inches minus 2 inches for radial taper and 1 inch for slabs); and b , the average width of board lost, is 7 inches. The deduction by the standard rule is—

$$\frac{3 \times 7 \times 4}{15} = 6 \text{ board feet, or rounded off to the nearest ten, 1.}$$

The net scale of the log is: $8 - 1 = 7$, or 70 board feet, the same as that obtained by the usual method. It will be noticed from 11, figure 6-10, that sufficient depth was added in determining a to allow for sawing straight boards inside the fire scar and b was merely the average width of board lost. Wormholes, usually occurring on only one side of the log, may be deducted in the same way as a fire scar.

6-18. Frost Check

a. Frost check is a separation of the wood along the tissue which separates the annual rings, (layers). It follows the grain of the wood. If the grain of the wood is straight, the loss from frost check is comparatively small, but if the log is spiral grained, as in 4, figure 6-10, the loss is considerably greater. The defective part is deducted as a piece whose base is a sector of the cross section of the log. In the 12-inch, 16-foot log illustrated in 4, figure 6-10, the affected wood takes up 12 inches of the 50 inches circumference at the large end, or approximately $1/4$ of $8 = 2$. The net scale of the log would be $8 - 2 = 6$, or 60 board feet.

b. If the frost check enters the log only part way, just the affected part of the sector is deducted. Suppose that the frost check in the log of 4, figure 6-10, had penetrated only 2 inches into the log. The solid core inside the log would have a diameter of $12 - (2 \times 2)$ inches $= 12 - 4 = 8$ inches (inside the bark) at the small end. The scale of an 8-inch, 16-foot log is 3. The volume of a collar 2 inches thick is, therefore, 8 (scale of 12-in., 16-foot log) minus 3 (scale of 8-in., 16-foot log) equals 5, or 50 board feet. Only $1/4$ of this was affected; hence, the deduction is $1/4$ of 50, or $12\text{-}1/2$ board feet, or rounded off to the nearest ten, 1. The net scale of the log would be: $8 - 1 = 7$, or 70 board feet. If the check had spiraled all the way around the tree, the net scale would be the scale of a log inside the check, or 30 board feet.

c. Where the check extends only part way up the log, the deduction is first made on the basis of a short section including the length of the check.

6-14

The deduction is then subtracted from the gross volume of the whole log. Lightning scars are treated in the same way as frost checks in scaling.

6-19. Punky or Broken-Down Sapwood

Deduction for this defect, illustrated in 6, figure 6-10, is made by reducing the diameter inside bark at the small end of the log by twice the radial depth of the defect. The figure shows a log 12 inches in diameter inside bark at the small end, 16 feet long, with a gross scale of 8, or 80 board feet. The sapwood is defective for a depth of 2 inches all around the log. The log is scaled as an 8-inch ($12 - 2 \times 2 = 8$), 16-foot log, having a scale of 3, or 30 board feet. If cull logs are all those whose net scale is less than 50 percent of the gross scale, this log would be a cull.

6-20. Wind Checks

This type of defect is illustrated in 8, figure 6-10. Deduction is made by reducing the small end diameter as for broken-down sapwood, except that only one-half of the average radial length of check is used as the radial depth of defect. Only a one-half deduction is made because the loss from this type of defect is not nearly so great further in the log as it is at the surface. The log in 8, figure 6-10, is 12 inches in diameter (inside the bark) at the small end, is 16 feet long, has a gross scale of 8, or 80 board feet, and has wind checks all around the log entering the log to an average depth of 2 inches. Half the average length of check is 1 inch. The log is scaled as a 10-inch ($12 - 2 \times 1 = 10$), 16-foot log, having a scale of 6, or 60 board feet.

6-21. Crook

In making deductions for crook or sweep, all the crook or sweep is thrown into the small end of the log and deduction is made from this top half. A right cylinder is drawn with a diameter equal to the small end of the log but with a length parallel to the lower half of the log. Deductions are made for the part of this right cylinder falling outside the log. The log in 10, figure 6-10, has a diameter at the small end of 12 inches and a length of 16 feet. The outside edge of the right cylinder falls 4 inches outside of the outer edge of the log at the small end. It appears that approximately $1/3$ of the upper half of the log is affected by the crook. Some 10- and 12-inch boards can be cut in this affected third, but it appears that about $2/3$ of this affected portion will be lost. The gross volume of a 12-inch, 16-foot log is 8, or 80 board feet. The

upper half includes 1/2 of 80, or 40 board feet. The affected 1/3 of this upper half contains 1/3 of 40, or 13 board feet. The part lost amounts to 2/3 of the affected portion, or 23 of 13 = 8 board feet, which, when rounded off to the nearest 10 board feet, gives a deduction of 1. The net scale of the log is: 8 - 1 = 7, or 70 board feet. While this method sounds complicated on paper, an experienced scaler carries on all these calculations in his head while looking at the log and has no difficulty at all in making the deduction rapidly.

6-22. Crotch

Deduction for crotch in scaling logs is illustrated in 12, figure 6-10. The diameter of the log (inside the bark) is measured below the swelling caused by the crotch. The piece lost due to the crotch is indicated in the figure. It is taken out as a rectangle by the standard rule. The log shown in 12, figure 6-10, has a diameter (inside the bark) below the swelling of 12 inches and a length of 16 feet, with a gross sciae of 8, or 80 board feet. The thickness lost inside the right cylinder and slab, *a* is 5 inches; and the average width of board lost inside the right cylinder and slab, *b*, is 11 inches; the length of the crotch is 3 feet, which will be called 4 feet if off-length boards are not merchantable. By the standard rule the deduction is—

$$\frac{5 \times 11 \times 4}{15} = 15 \text{ board feet, or rounded off to the nearest 10, 1.}$$

The net scale is 8 - 1 = 7, or 70 board feet. Frequently the diameter below the swelling is not actually measured but is computed by subtracting a taper allowance from the diameter inside bark at the large end of the log.

6-23. Deductions for Defect Board Feet, Using International One-Fourth-Inch Rule

a. In scaling logs by the international 1/4-inch

log rule (table 6-2) the procedure is like that for the Scribner decimal C rule, with only such modifications as required by the differences in construction of the two rules. Since there is a deduction of 1/16 inch for shrinkage in addition to the 1/4-inch saw kerf deduction, the standard rule for defect deductions becomes $\frac{a \times b \times L}{16}$ in which

a is the thickness or depth of the defect, in inches, *b* is the width of the defect, in inches, and *L* is the length of the defect, in feet. This rule is amply generous in its allowance for defect, and it is not desirable to add 1 inch to these dimensions for sawing around the defect. This applies especially to a circular defect for which the standard rule

becomes— $\frac{D^2 \times L}{16}$ in which *D* is the average

diameter of the defect in inches and *L* is the length of the defect in feet. Since the international 1/4-inch rule allows for a taper of 1/2 inch per 4 feet of length, the diameters of any defect appearing at both ends of the log should be averaged in obtaining *D*, regardless of the length of the log.

b. Unlike the Scribner decimal C rule, the international 1/4-inch rule does not set up a right cylinder outside of which no deductions should be made. Instead, it sets up a cone frustum (a cone with its top cut off by a plane parallel to the base). The top diameter of the frustum is the top diameter (inside the bark) of the log, and the frustum has a uniform taper of 1/2 inch for every 4 feet of log length. A collar of 1 inch in radial thickness is allowed for slabs within this frustum. Any defect or part of a defect falling outside the cone frustum or its slab collar is disregarded in scaling by the international 1/4-inch log rule. In conformity with the method of constructing the rule, all deductions for defect are rounded off to the nearest 5 board feet.

Table 6-2. International Log Scale

Diameter (inches)	Length (feet)												
	8	9	10	11	12	13	14	15	16	17	18	19	20
	Contents (bd ft) in tens												
6	10	10	10	10	15	15	15	20	20	20	25	25	25
7	10	15	15	15	20	20	25	25	30	30	35	35	40
8	15	20	20	25	25	30	35	35	40	40	45	50	50
9	20	25	30	30	35	40	45	45	50	55	60	65	70
10	30	35	35	40	45	50	55	60	65	70	75	80	85
11	35	40	45	50	55	65	70	75	80	85	95	100	105
12	45	50	55	65	70	75	85	90	95	105	110	120	125
13	55	60	70	75	85	90	100	105	115	125	135	140	150
14	65	70	80	90	100	105	115	125	135	145	155	165	175
15	75	85	95	105	115	125	135	145	160	170	180	190	205
16	85	95	110	120	130	145	155	170	180	195	205	220	235
17	95	110	125	135	150	165	180	190	205	220	235	250	265
18	110	125	140	155	170	185	200	215	230	250	265	280	300
19	125	140	155	175	190	205	225	245	260	280	300	315	335
20	135	155	175	195	210	230	250	270	290	310	330	350	370
21	155	175	195	215	235	255	280	300	320	345	365	390	410
22	170	190	215	235	260	285	305	330	355	380	405	430	455
23	185	210	235	260	285	310	335	360	390	415	445	470	495
24	205	230	255	285	310	340	370	395	425	455	485	515	545
25	220	250	280	310	340	370	400	430	460	495	525	560	590
26	240	275	305	335	370	400	435	470	500	535	570	605	640
27	260	295	330	365	400	435	470	505	540	580	615	655	690
28	280	320	365	395	430	470	505	545	585	625	665	705	745
29	305	345	385	425	465	505	545	590	630	670	715	755	800
30	325	370	410	455	495	540	585	630	675	720	765	810	855
31	350	395	440	485	530	580	625	675	720	770	820	870	915
32	375	420	470	520	570	620	670	720	770	820	875	925	980
33	400	450	500	555	605	660	715	765	820	875	930	985	1,045
34	425	480	535	590	645	700	760	815	870	930	990	1,050	1,110
35	450	510	565	625	685	745	805	865	925	990	1,050	1,115	1,175
36	475	540	600	665	725	790	855	920	980	1,045	1,115	1,180	1,245
37	505	570	635	700	770	835	905	970	1,040	1,110	1,175	1,245	1,315
38	535	605	670	740	810	885	955	1,025	1,095	1,170	1,245	1,315	1,390
39	565	635	710	785	855	930	1,005	1,080	1,155	1,235	1,310	1,390	1,465
40	595	670	750	825	900	980	1,060	1,140	1,220	1,300	1,380	1,460	1,540

CHAPTER 7

TRANSPORTING LOGS

Section I. SKIDDING LOGS WITH CHOKER CABLES, FLOATING LOGS, MOVING LOGS IN FLUMES AND CHUTES, AND LOADING LOGS

7-1. Introduction

This section discusses the transporting of logs in the forest and to the sawmill. It describes skidding logs with the use of choker cables, floating logs, moving logs in flumes and chutes, and loading logs. The method that is selected depends on the size and weight of the timber to be handled, the terrain to be crossed, the cut per acre, and the total amount to be transported.

7-2. Mechanical Power With Safety Features

The military type crawler tractor used for logging has a front-mounted power control unit and a rear-mounted winch. The rear winch is reversible and may be used to skid the logs from the stump to the skid road. The tractor is large enough, 17,100- to 24,000-pound drawbar pull, to handle any skidding job encountered.

a. Safety Accessories.

(1) *Guards for tractor.* The tractor must be equipped with a steel guard for the underside of the crankcase, a heavy-duty radiator guard, and guards for the lower tracks and wheel bearings. If the tractor is operated without the angled dozer blade, a heavy front bumper should be attached. It is usually advisable to remove the blade if extremely steep slopes are to be negotiated. The blade will dig in, hang, and gouge the roadbed.

(2) *Operator guard.* Protection from falling tree limbs and from breaking cables is needed for the operator. Two guards that give this protection from overhead and from the rear are shown in figure 7-1. The steel roof plates should be at least 1/4 inch thick. The grill behind the operator should be a 1- to 2-inch mesh of 1/4-inch rods.

b. *Tracks.* For most purposes, a heat-treated one-piece shoe as wide as can safely be carried on the sprockets is desirable for the skid tractor. For

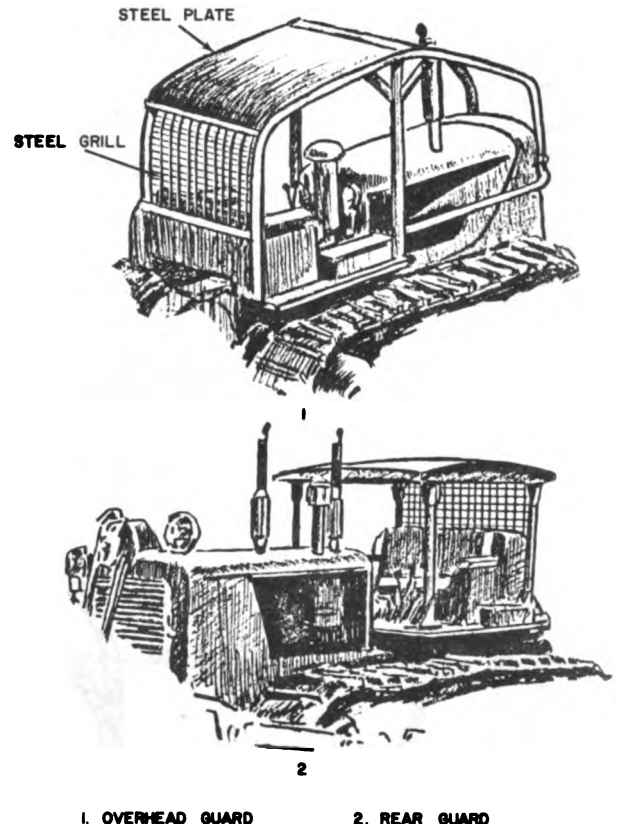

1. OVERHEAD GUARD 2. REAR GUARD
Figure 7-1. Guards to protect the tractor operator.

winter use, a skeleton track with a hole about 4 to 6 inches in the center of each track plate helps keep the snow from packing on the tracks.

c. *Logging Winch.* In addition to the single-drum, reversible winch normally supplied with the crawler tractor, there is available a tractor-mounted, three-drum, two-speed winch designed specifically for the logging operation. This winch is called a tractor donkey and consists of the following:

(1) Main drum with a 1-inch cable capacity of 960 feet.

(2) Haulback drum capable of holding 2,360 feet of 7/16-inch cable.

1 CONVENTIONAL HOOK

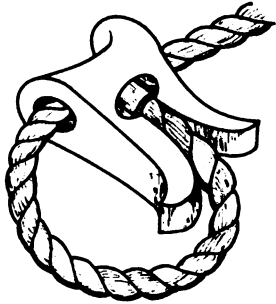

2 CHOKER HOOK

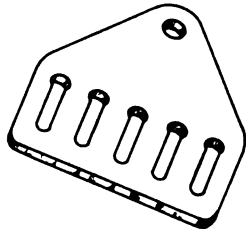

3 DRAWBAR HOOK

Figure 7-2. Choker and choker hooks.

7-3. Chokers and Choker Hooks

a. *Description.* A choker is a short length of flexible wire rope used for skidding logs. One end is fastened to the log by means of a sliding loop attached to a swivel; the other end is fastened to the tractor. The swivel should always be used since choker cables, without swivels, used for towing logs tend to deteriorate rapidly due to the rolling and turning action of the towed log.

(1) *Conventional hooks.* A conventional hook (1, fig 7-2) on the end of the choker makes the choker easier to attach to a log. If the hook is constructed properly, it causes less wear on the cable than a spliced eye does. However, a hook becomes disengaged rather easily, often resulting in loss of all or part of the load.

(2) *Choker hooks.* The choker hook (2, fig 7-2) is the best device for securing logs. Its construction allows the cable to run freely through the sleeve when the log is secured.

(3) *Drawbar hooks.* The drawbar hook (3, fig 7-2) can be attached directly to the tractor drawbar on secured on the end of the logging winch

(3) Strawdrum capable of holding 2,940 feet of 5/16-inch cable.

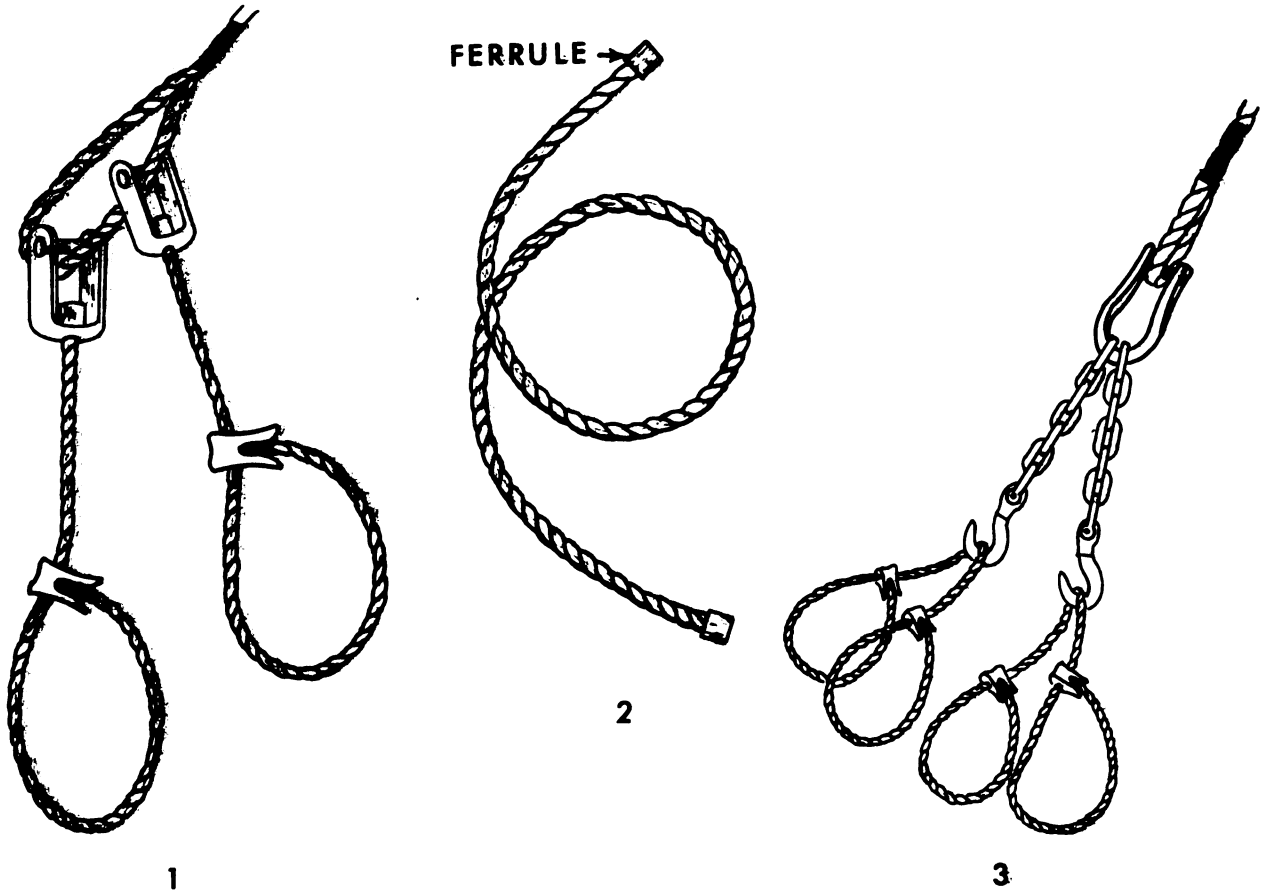

Figure 7-3. Choker hook rigging.

wire rope. The chokers are attached to the hook.

b. *Rigging.* One or more of the choker hooks can be attached to an eye loop (1, fig 7-3) if clevises are attached. This makes it possible to use chockers with ferrules at both ends (2, fig 7-3). These have the advantage of being reversible, and they wear longer and more evenly. Three or four short lengths of chain can be used to multiply the number of chokers that can be attached (3, fig 7-3).

7-4. Ground Skidding

Tractors can be used for skidding logs on the ground; however, ground skidding should be avoided whenever other methods are available. As shown in figure 7-4, there are many methods of securing the logs for skidding. They include slip chains, skidding tongs, crotch grabs, and grabs (2, 3, 4, and 5 of fig 7-4).

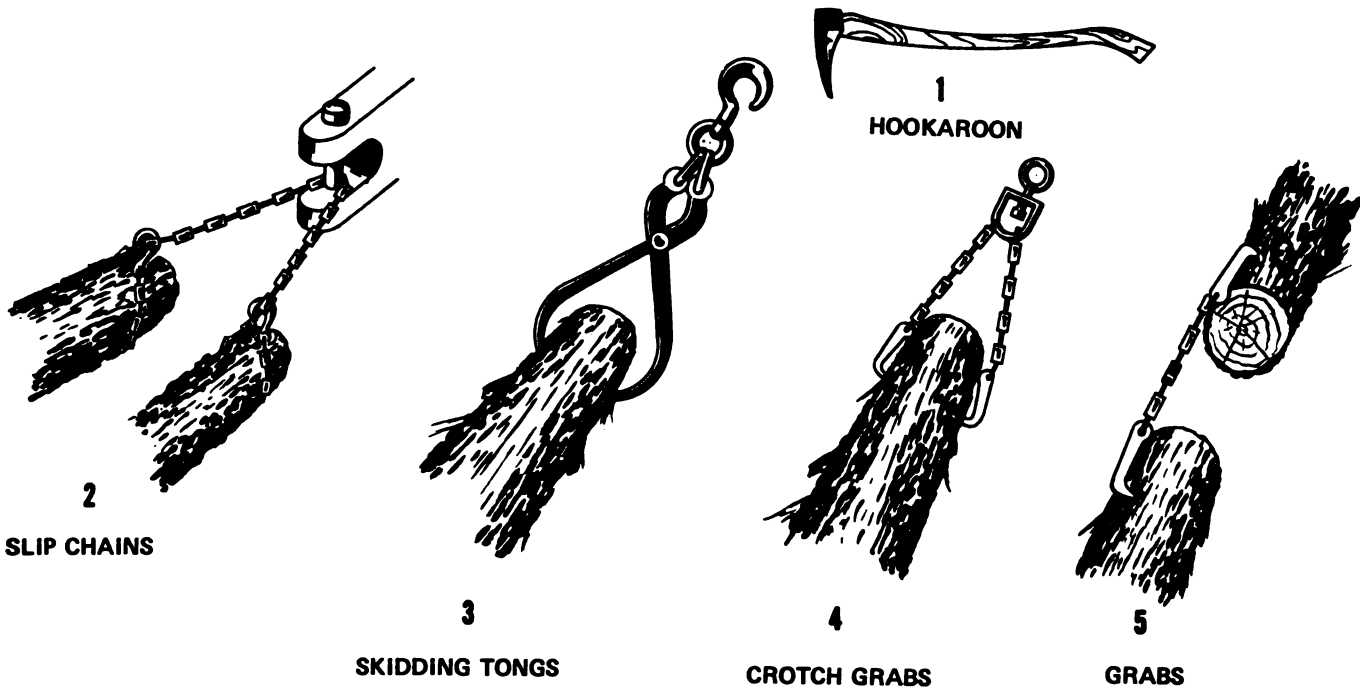

Figure 7-4. Securing logs for ground skidding.

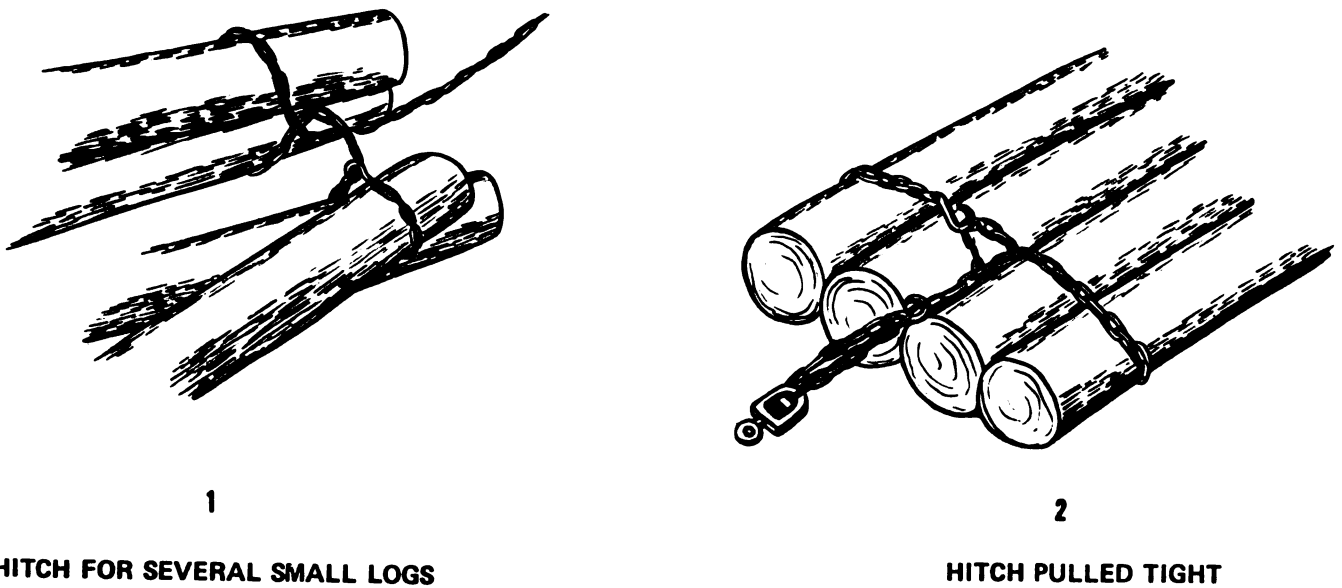

Figure 7-5. Hitch for light logs and poles.

a. *Light Logs and Poles.* A 10- to 12-foot chain is used with a slip hook on one end and a clevis on the other. The logs are secured with the slip hook and chain as shown in 1, figure 7-5. The chain must be far enough down the log so that it does not slip off when it is pulled tight (2, fig 7-5). The towing chain is kept as short as possible in order that the pulling action of the tractor will raise the ends of the logs slightly to prevent their digging in as they are skidded.

b. *Heavy Logs.* For ground-skidding heavy logs, the slip-chain hitch (a above) can be used. However, the increased friction of a heavy chain across the underside of the log makes it harder to move. The crotch grab (4, fig 7-4) and skidding tongs (3, fig 7-4) are usually more adaptable to heavy work.

(1) *Crotch grabs.* The grabs are placed in position on the side of the log and a hookaroon or grab skipper (1, fig 7-4) is used to drive them into the log. The grabs must be located down the log far enough so that they will not split out when the skidding begins. To remove the grabs, the sharp end of the hookaroon (grab skipper) is used to pry them free of the log.

(2) *Skidding tongs.* The tongs are set in position on the log with sufficient "bite" to take hold when the skidding begins. Sometimes it may be advisable to set the tongs with a maul. To remove the tongs, the strain on the towing chain is slackened and the tongs will fall free with a small amount of prying.

(3) *Grabs.* As shown in 5, figure 7-4, the grabs may be used to form a train of logs. The grabs are set in position in the same way the crotch grabs are set. Care must be exercised in locating the grabs so that when skidding starts the logs do not roll over and thereby become fouled in the ground. The grabs are removed with a hookaroon or grab skipper.

(4) *Damage to small logs.* Logs of small size are sometimes seriously damaged when tongs or grabs are used. If it is necessary to use tongs or grabs on small logs, sufficient allowance must be made for this damage when the logs are bucked.

c. *Ground-Skidding Procedure.*

(1) Do not skid logs on the ground behind a tractor for distances over 500 feet. For longer skids an improvised anti-friction device or logging arch will increase the load capacity and greatly speed up the operation. For short skids, and where numerous turnarounds are necessary, the tractor has greater maneuverability without a trailing device.

(2) Position the tractor drawbar as close to the front end of the trailing load as possible. Secure the skid chain to the drawbar and move the tractor slowly ahead until the chain is taut. Check to see that all the logs are secure before proceeding.

(3) Start the load off slowly to avoid jerking loose the slip chains or grabs. On curves and turnarounds always keep the tractor on the outside so that the logs will have enough space to trail the tractor on the skid road. Turning the tractor sharply on the inside of curves will cause the logs to trail off the road and strike obstructions. If a muddy area or steep grade is encountered, pay out the winch cable while driving the tractor ahead to better ground; then use the winch to pull the load up to the tractor. Logs raised a few inches above ground level at the hitch will move over obstructions more easily than if logs are skidded lying flat on the ground. Make sure that the larger obstructions are avoided or, if encountered repeatedly, removed.

d. *Log Winching.* For winching the log from the stump to the skid road, hitches with chokers, chains, tongs, or grabs may be used. The logs may be winched individually or in a bunch. The operator of the winch will need an assistant to secure the log at the stump and to walk with the log as it is drawn towards the tractor. The assistant should aid in getting the log around obstructions and at the same time give instructions to the winch operator. Logs are seldom winched over 200 feet because of the many difficulties encountered in skidding the logs through heavy underbrush and around trees and stumps.

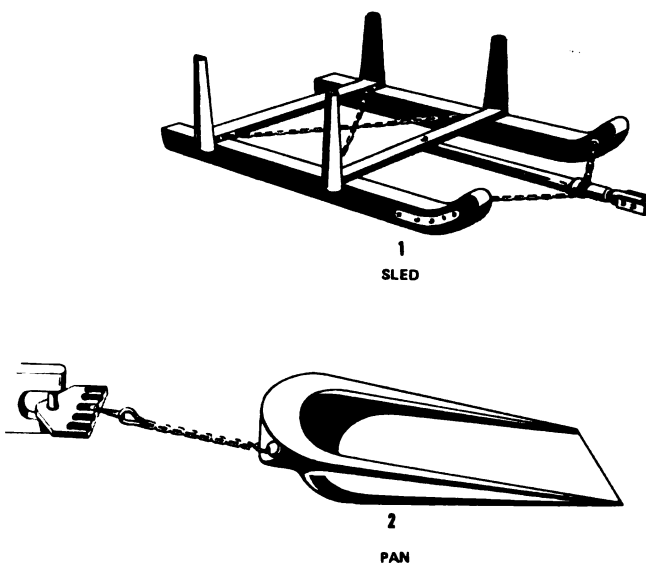

Figure 7-6. Ground skidding devices.

7-5. Skidding With Sleds and Pans

Although sleds or pans are not available through military supply channels, they may be easily fabricated in the field. As shown in figure 7-6, they are of simple construction. The sled (1, fig 7-6) is constructed of heavy timbers and the pan (2) can be made up from any heavy steel plating.

a. Sleds. On the sled, the logs are cradled between the chocks and bundled with one or two log chains. The sled tongue is attached to the tractor drawbar. The sled is best used on flat or gently rolling terrain. Although the sled has many uses, its wood construction cannot stand rugged handling and its capacity is limited to small poles and logs.

b. Pans. The pan is attached to the tractor drawbar, preferably by using a short length of chain and a Bardon drawbar hook (2, fig 7-6). Each log is pulled with a choker, which is also hooked to the drawbar. The skidding pan arrangement provides considerable flexibility. The tractor operator can drive up beside a log, encircle it with the choker, drop the other end of the cable into the socket, and then proceed to the next log, being sure that the front end of each log hooked will roll upon the pan. This operation can be repeated until the pan (or drawbar socket) is full. At the landing, a slight backward movement of the tractor will permit ready disengagement of the chokers. The skidding pan allows most of the log to drag in the dirt, so that there is still much friction to overcome and logs will be encrusted with dirt.

7-6. Skidding With Tractor Arches

a. Description. The best rig for skidding logs is the tractor equipped with a winch and logging arch (fig 7-7). The cable from the tractor winch, called the dragline, runs up the top of the reach and through the fairlead. The fairlead allows logs or poles to be pulled in from the sides for bunching, and then to be pulled up into the arch for skidding to the truck or yard.

b. Use of the Arch. The most important factor in efficient use of an arch in the woods is to make sure that the trees are felled in the right direction (fig 4-1). This usually means dropping them at an angle of up to 45° to the road, away from the direction in which they are to be hauled out. If they are dropped in this manner, the choker setter (member of the logging crew who places the chokers on the logs) can roll them from behind stumps or other obstructions and attach the chokers; then the tractor winch can quickly and easily pull the

logs to the road. In bunching this way, logs pulled uphill are under better control and do less damage to the timber left standing. On some operations it is more efficient to have another tractor bunch the logs at the side of or in the skid road. This is done in unusually rugged, rocky country, where tractor skid roads are difficult or expensive to make, or where extra heavy tractors are being used on long hauls. Usually it is more economical to place the tractor skid roads close enough together so that the tractors can do their own bunching. Trees should be felled so that they can be dragged out most easily.

7-7. Cable Logging

Cable systems are not recommended unless absolutely necessary. Highspeed cable systems are expensive to install and operate. They damage timber and are dangerous to the personnel working around them. However, cable systems are the only means of logging some areas efficiently. These include places that are so rough or swampy that other types of logging equipment cannot be used to get the logs out.

a. Ground Skidding Over a Cliff. In working over a cliff, the cable may receive a great deal of wear from sharp rock edges. One way to avoid this is to construct a simple boom that can be backed out to the edge of the cliff and carry the cable over the edge (1, fig 7-8). With such a boom, logs scaling up to 3,000 board feet have been lifted with a 60-horsepower winch.

b. Skyline Logging.

(1) Getting logs out of a ravine is difficult. If the sides are steep and rough, the bottom rough or swampy, or the mouth blocked, ordinary logging vehicles cannot be used. Such ravines often can be logged best by using the skyline system (2, fig 7-8).

(2) The skyline is stretched across the ravine from a head spar on the landing side to a tail spar on the other side. Neither needs to be very high; in fact, a stump can often be used for a tail spar. The skyline is usually tightened by a block and tackle and a hand winch. The main dragline passes through a sheave on the head spar, to a carriage (bicycle rig) (fig 7-9) suspended on the skyline, down through a fall block, and back to the skyline carriage where the end is fastened. Motive power is usually provided by a large capacity winch set well back from the cliff edge. When the winch is put into free wheeling or reverse, the dragline cable pays out until the carriage is at the

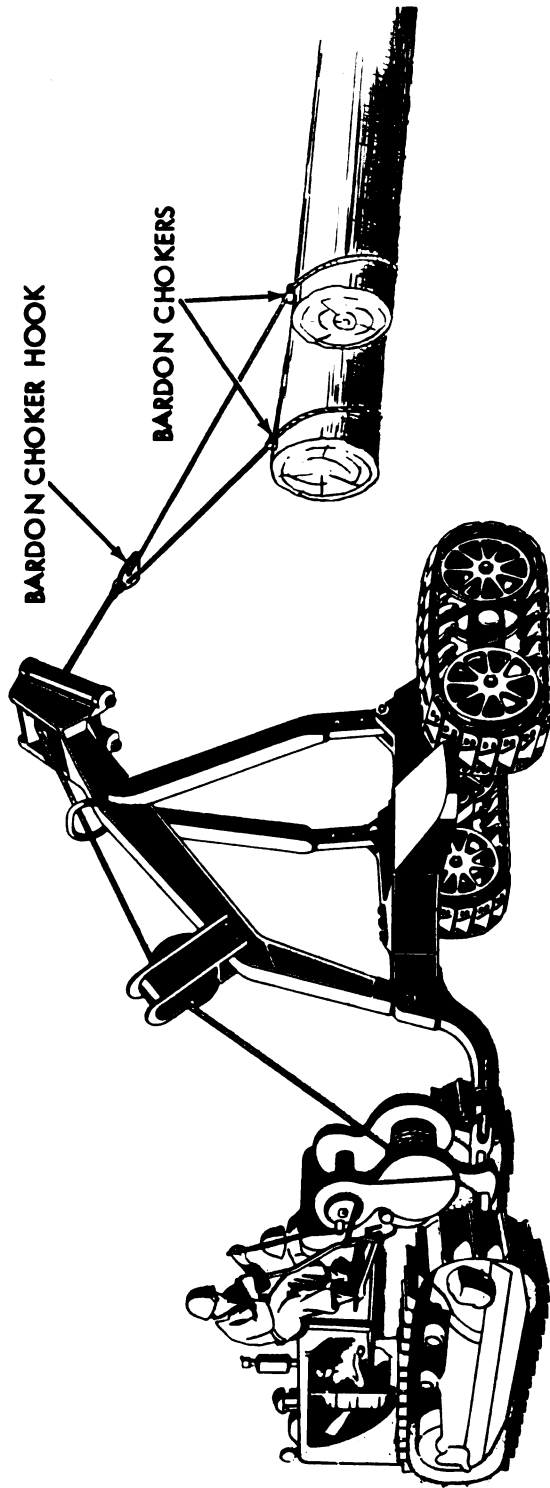

FB-342-55

Figure 7-4. Tractor and arch skidding.

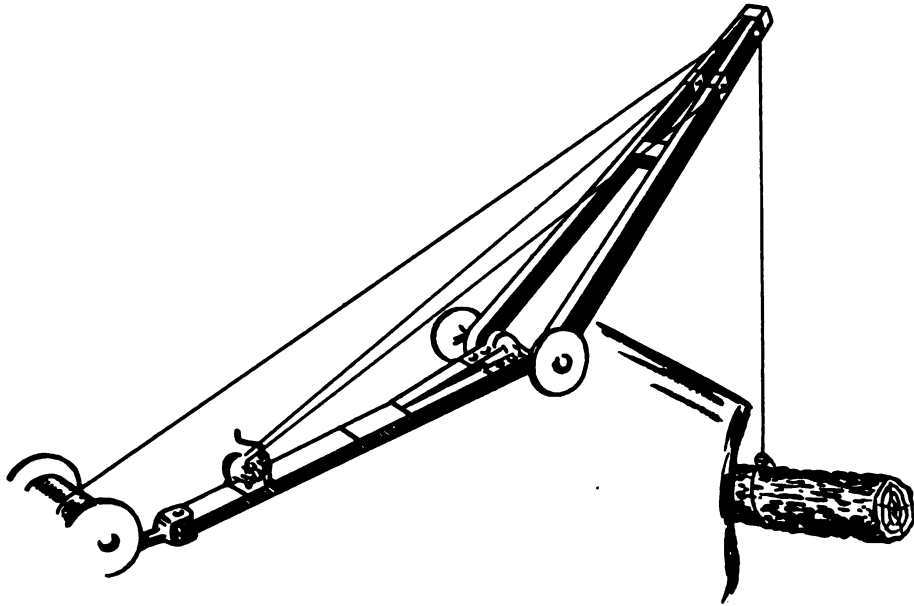

1

FIELD IMPROVED BOOM FOR WORKING OVER A CLIFF

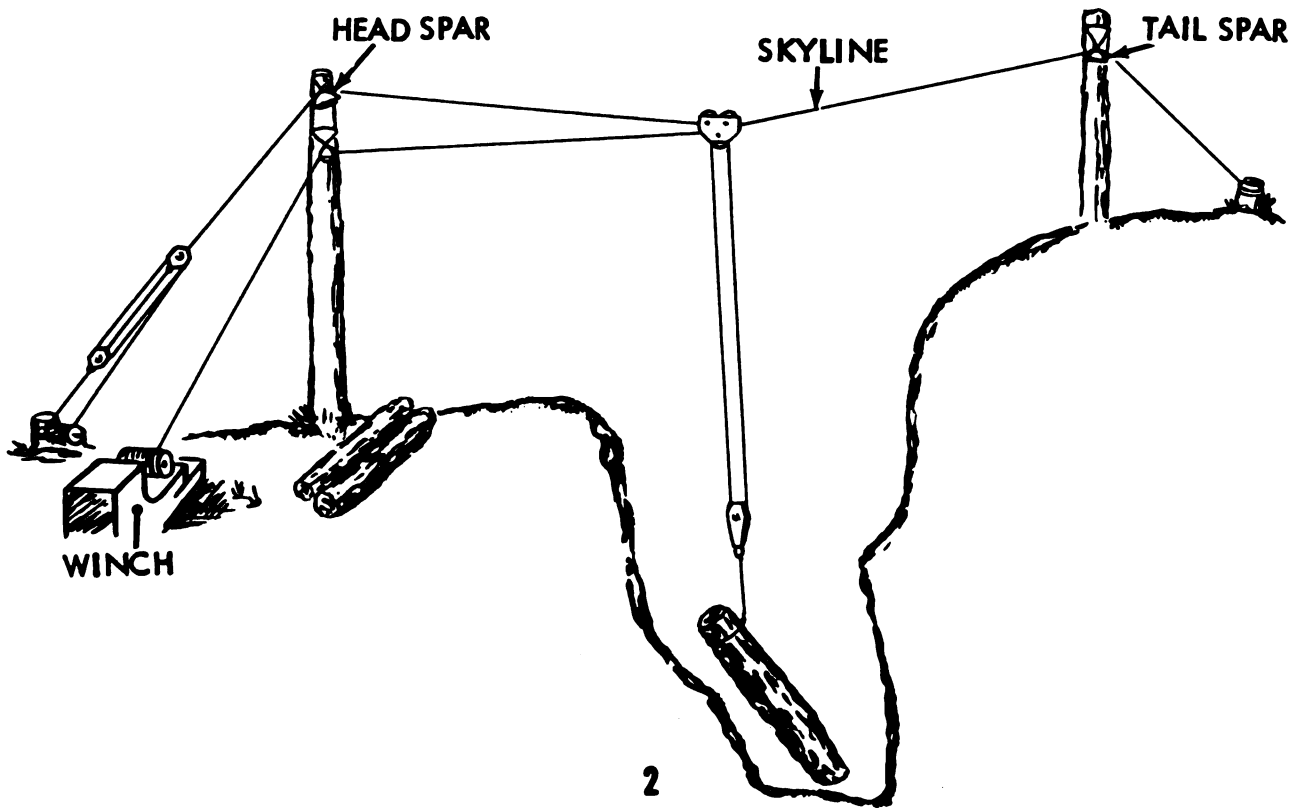

2

LOGGING A BOX CANYON WITH A SKYLINE

Figure 7-8. Cable logging over a cliff.

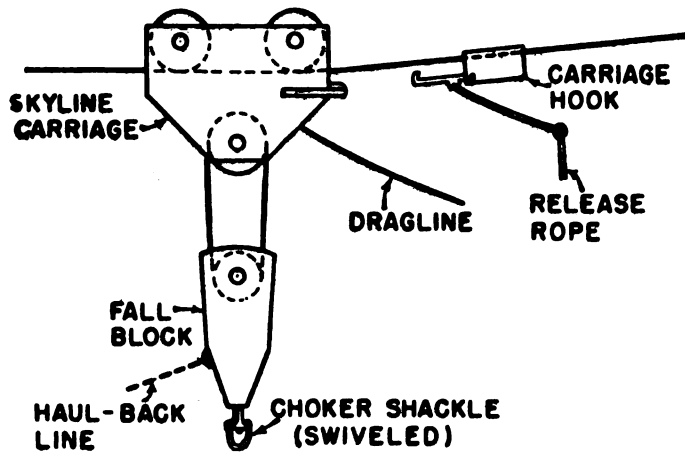

FB-342-57

Figure 7-9. Sky carriage and automatic hook.

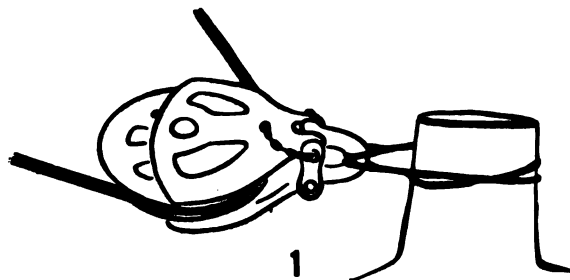

HAULBACK BLOCK

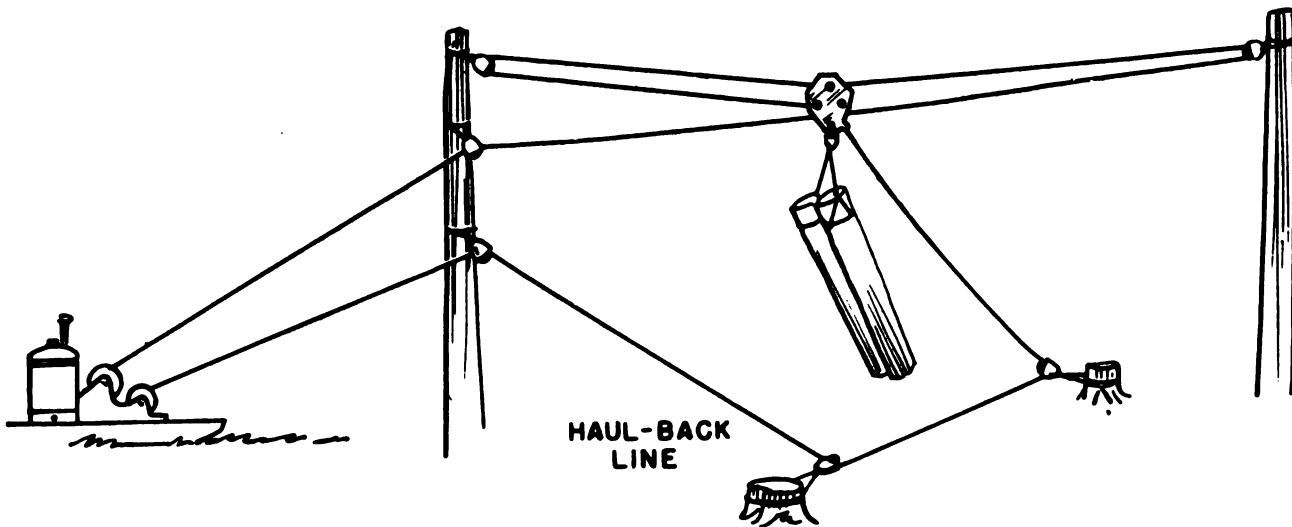

THE DUNHAM SKYLINE SYSTEM

Figure 7-10. Skyline systems.

center of the skyline, and the heavy fall block carries the choker shackle down within reach of the hookup men at the bottom of the ravine. When the log is hooked on, they give the winch operator a signal. He puts the winch into gear, and the log is lifted up and out of the canyon. An automatic hook on the skyline near the head spar makes it easy to hold the carriage and lower the log at the landing on top of the cliff. The winch operator can release the hook by a pull on the release rope.

(3) If a double-drum winch can be provided, a light haulback line will speed up the operations by providing quicker, surer return of the fall block to the hookup man. The haulback line is run from the fall block, through a light haulback block (1, fig 7-10) attached to a stump at the bottom of the ravine, up to a sheave on the head spar, and thence to the second winch drum. Additional haulback blocks can be used if needed. These haulback blocks are arranged with an easily detachable shackle so that they can be taken off the line, moved, and reattached in a very short time.

(4) There are many variations of the skyline system, one being the Dunham system (2, fig 7-10). In this system the main dragline is also the skyline. It is doubled back so that the carriage runs on it. This system cannot be used without a haulback. When the haulback is restrained and the main dragline is hauled in, the carriage and its load are lifted into the air.

(5) Skylines work best, regardless of rope sizes, when the setup is such that considerable slack can be left in the line. Getting the skyline too taut greatly increases the pull on the spar trees and on the rope itself, and cuts down on the working load that can be carried. This is illustrated in table 7-1, which gives the safe load capacities of wire ropes of various diameters over a 1,000-foot span with different amounts of deflection from the horizontal.

c. High-Lead Systems. The high-lead system (fig 7-11) has been replaced for the most part by tractor logging. High-lead systems are very expensive in manhours and material required for their erection, operation, and maintenance; they can be damaging to timber not yet harvested and they are dangerous to the men working around them. However, there are some slopes where a tractor cannot be used, and where a high lead is the best way for getting the logs out. A typical example is a rocky hillside (1, fig 7-11) with a road at the top. Another is where there is a steep-sided gully (2, fig 7-11) between the landing

at the roadside and the opposite slope where the logs are located.

Table 7-1. Safe Working Loads¹ for Wire Rope (6 x 19 Plow Steel) on Horizontal Skylines (Based on Span of 1,000 Feet)²

Deflection at center of line (feet)	½-inch rope	¾-inch rope	1-inch rope	1½-inch rope	Rope needed
	Pounds	Pounds	Pounds	Pounds	Feet
20	140	320	580	1,220	1,001
30	340	740	1,300	2,760	1,002
50	720	1,560	2,780	6,000	1,007
100	1,640	3,560	5,960	13,920	1,027
200	3,240	7,100	12,500	26,400	1,107

¹ With a safety factor of 4 (TM 5-725).

² For longer spans with equal deflections, the working loads are much lower. (For 2,000-foot span, 1½-inch rope at 100-foot deflection, the safe working load is 4,800 pounds.) Green hardwood logs weigh about 10,000 pounds per 1,000 board feet, softwoods about 7,000 pounds.

(1) The principal advantage of the high lead system is that it lifts the front end of the logs (3, fig 7-11), helping them to pass over rocks, stumps, and other obstructions. This advantage lessens as the length of the skid increases. With a 40-foot spar in level country, a high-lead can skid logs efficiently about 200 feet. A 60-foot spar will extend the distance to 300 feet. On uphill skids the lifting effect may apply over a slightly greater distance, depending on the configuration of the ground. Downhill, the practical skidding distance may be much less.

(2) An important part of a high-lead system is the butt rigging used (fig 7-12). It should be fitted with swivels to reduce the possibilities of kinking the wire ropes attached to it.

(3) By a modification of the high-lead system, it is possible to get a good lifting effect over longer skids with a relatively low head spar. This is done by using the haulback line to take the slack out of the main haul line and thus lift the load. This modified system is called the tight-lining system (1, fig 7-13).

(4) Under ideal conditions, the tail block can be fastened to a stump. On more uniform slopes or nearly level settings, it is necessary to rig a tail tree. The system works the same either way. Whether it is necessary to lift a load of logs over rocks, logs, or other obstructions, the operator puts brake pressure on the haulback drum. A special free-swiveling butt rigging (2, fig 7-13) is best for such a setup. The Montelius clevis is well adapted to this system.

d. Rigging. Rigging details for the cables on a skyline or a high-lead are covered in TM 5-725. The rigging and guying of an A-frame for either system is shown in figure 7-14. A head spar can

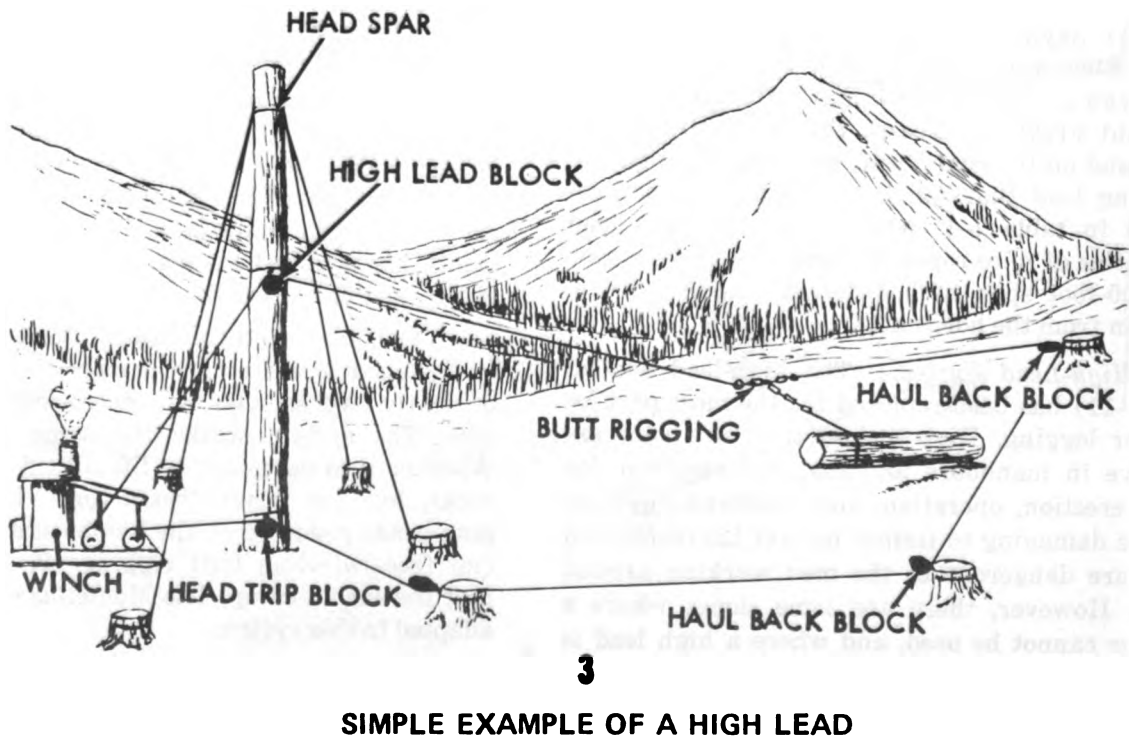
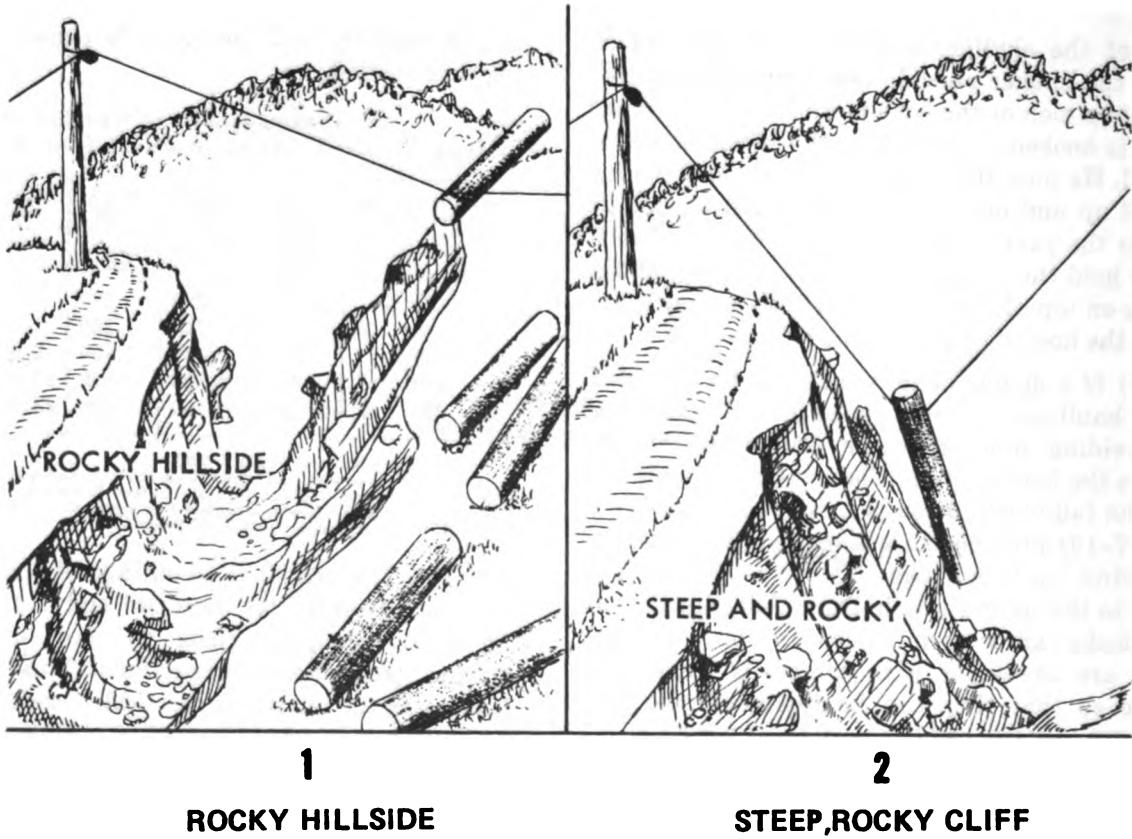

Figure 7-11. The high-lead system and its use.

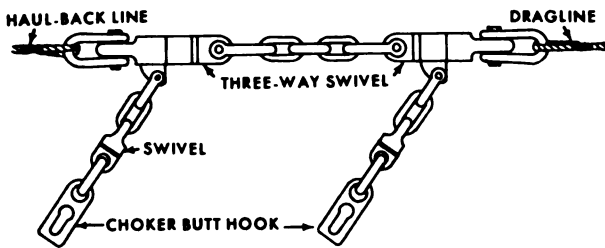
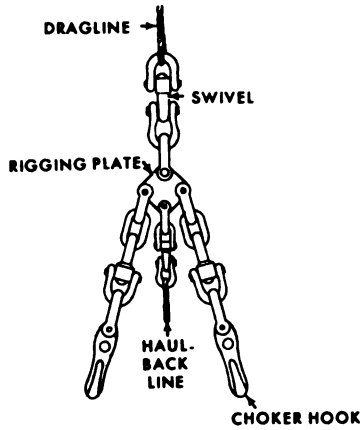
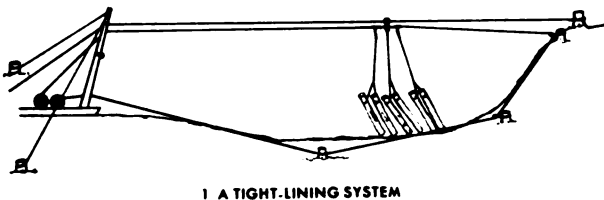
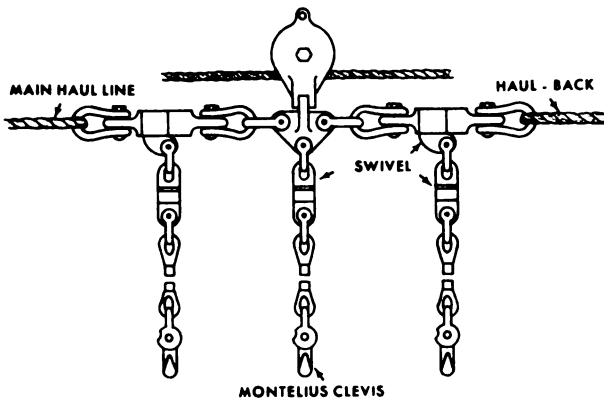

Figure 7-12. Two types of butt rigging for a high-lead system.



1 A TIGHT-LINING SYSTEM



2 BUTT RIGGING FOR A TIGHT-LINING SYSTEM

Figure 7-13. Use of the tight-lining system.

also be rigged on a standing tree. For safety, the tree should be topped and guyed. A head spar is subject to much pounding and vibration which may break limbs or loosen the tree. Frequently,

when the configuration of the ground is right, a stump can be used as a tail spar. If this is not possible, the lines can be fastened to a suitable tree which should be guyed. Ordinarily, it is not necessary to top the tail spar. The correct choice of the blocks to use in each situation will contribute a great deal to the efficiency of the operation as well as cut down on the number of breakdowns and accidents.

7-8. Loading

Loading forest products for the haul to the mill presents many problems in the design of the loading facilities for each location and each type of log handled. The variety of conditions under which loading has to be done adds to the number of systems and devices developed to help do the job. Loading can be either "hot," with the wood going onto trucks or sleds just about as fast as it is skidded from the woods; or "cold," with the wood accumulating at a yard or landing in quantity before it is to be loaded. Loading can be done on a level spot, or on a hillside from above or below the road. The material to be loaded may be short bolts, logs of various lengths, or entire tree lengths.

a. *Loading Short Bolts.* For handling limited amounts of short bolts, hand loading generally suffices. However, if large amounts are to be handled, a system of mechanical or semimechanical loading should be devised.

(1) One method (1, fig 7-15) that reduces handling of bolts to a minimum is the steel hoop and cradle. Here the wood is piled by hand in cradles in the middle of which welded hoops of steel reinforcing rods have been set. The last few bolts are pounded in with a mallet. The wood is then transported (2, fig 7-15) in these bundles. The hoops can be used again and again. These cradles are loaded at the point the bolts are cut and then skidded to the loading area.

(2) The method of handling bolts in (1) above is just one of many ways of doing the job. The logging supervisor can improvise as is necessary to get the job done. If the equipment is available, the use of forklifts, grapples, small crawler tractor-mounted cranes, improvised conveyor systems, and improvised trucks and trailers will save manpower and greatly increase the speed of the operation.

b. *Loading Sawlogs.* Logs and poles generally are too heavy to be lifted by hand for loading, although some small logs are loaded in this way.

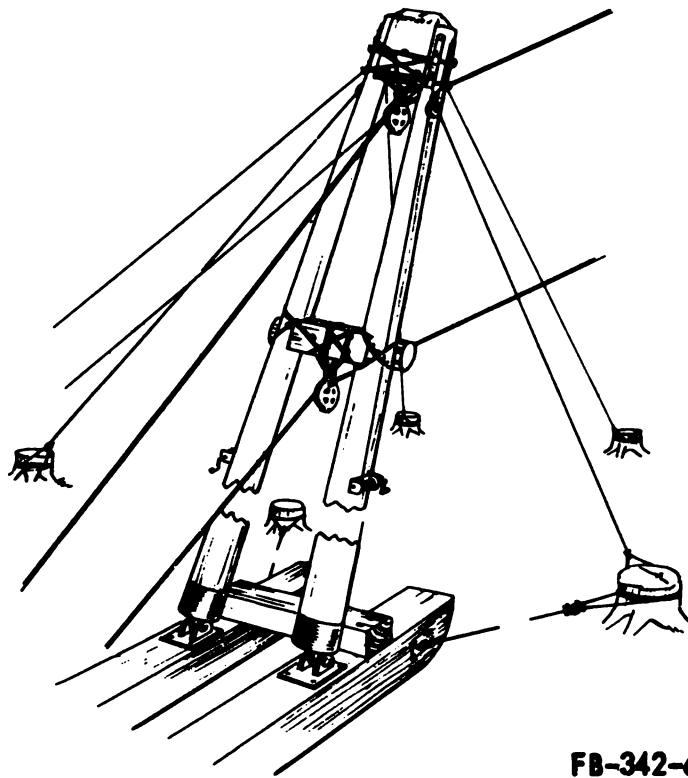

FB-342-62

Figure 7-14. A-frame rigging and guying.

Usually they have to be rolled or hoisted onto the bed of the truck or trailer. Logs can be rolled up inclined skids to the truck bed with the aid of a cant hook or peavy. Two men, one to hold the log while the other is getting a fresh grip, can do this with considerably more ease and safety than one man working alone. Spikes or notches in the skids help hold the logs from slipping and rolling back.

(1) In hilly country a loading point can usually be found where skids can be placed level between the slope and the bunks (crossbeams upon which the logs rest) of the truck. This may require long skids, which are apt to break. The best method of loading from the side of the hill is to construct a skidway out of cull logs. Such a skidway may be either single- or double-decked. As shown in figure 7-16, the double-deck skidway can best be utilized because it allows the logs to be loaded at different heights. When the truck arrives, the logs from the first deck are loaded in the first tier or two on its bunks. Then the skids are moved up between the next deck of the skidway and the top of the logs already loaded, and a third and possibly a fourth tier of logs can be loaded. Over long spans, a catwalk or plank from the skidway to the truck is sometimes provided for the log rollers to work on.

(2) On level ground, the cross-haul method can be used. Figure 7-17 illustrates the use of a small crawler tractor to pull the logs up the skid onto the bed of the truck. If there are great many logs to be loaded at the same location, a small skid-mounted winch should be substituted for the tractor.

(3) If a great deal of loading is to be done at one place and the logs are of medium to large size, a more permanent type of loading device should be considered. The double-tong device is the safest and fastest for the permanent type loading rig. Two such devices are the McLean boom and the crotch-line loader.

(a) One type is the McLean boom (1, fig 7-18). A spar must be erected, or a spar tree must be topped and guyed. The boom consists of two sturdy poles braced and secured as shown. If a counterweight swing is used, as illustrated, only one swing line is needed to carry the boom and its load to its position over the truck to be loaded. The counterweight swings it back when the single swing line is reeled out. The line to the lifting tongs is arranged on the hook of the boom loading block with one turn (to prevent slippage), so located that one portion of the line is sufficiently longer than the other to provide lifting of the

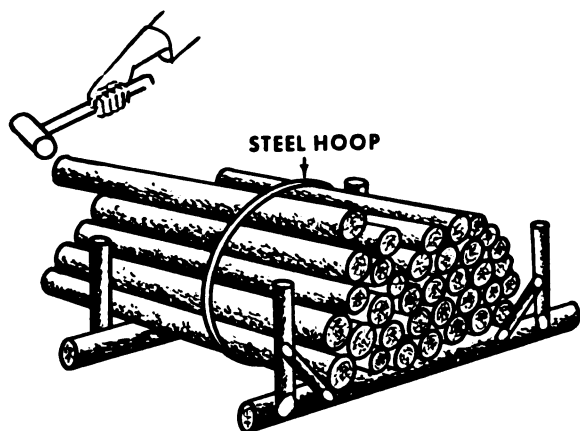

1 LOADING THE STEEL HOOP

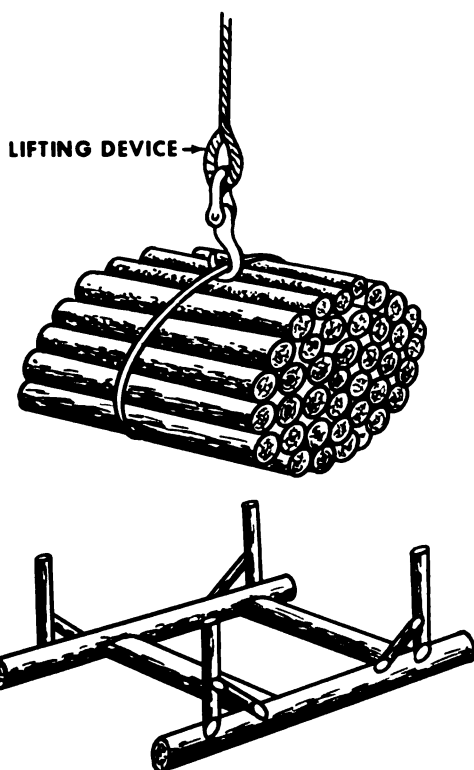

2 HANDLING THE LOADED STEEL HOOP

Figure 7-15. Handling short bolts.

two tongs simultaneously. Power for this can be provided by a double-drum winch on the back of a crawler tractor, or by a similar skid-mounted winch.

(b) The crotch-line loading system requires two spars, both provided for picking up or dropping the logs at any point between them (2, fig 7-18). The usual system is to have the log supply at one side of this space and the truck road at the other. The spreader for the tong lines is usually a length of old rail, with holes bored at

either end for the necessary clevises. The power for this device can also be supplied by a double-drum winch either tractor- or skid-mounted.

c. *Loading Tree-Length Logs.* Many of the devices described in *a* and *b* above can be used to handle tree-length logs. In addition, crawler-mounted cranes and stationary gin poles can also be used. The stationary McLean boom (1, fig 7-18) and the crotch-line loaders (2, fig. 7-18) are especially well adapted for loading tree-length material.

d. *Preloaders.*

(1) The log preloader (1, fig 7-19) is peculiarly adapted for use with tree lengths. The screwjack raises the tree-length logs slightly above the level of the truck body. The truck is then backed under the ends of the logs extending beyond the screwjack and the screwjack is removed. The truck is then backed again until the logs are properly loaded on the bunks. Most of the devices suspend the load in such a position that the truck can be backed under it and the load dropped on the bunks, chained down, and hauled away. The advantage is that the truck does not have to wait while its load is being assembled. Also the loading crews can work at a steadier, safer pace, instead of waiting for a truck to be loaded and get on its way.

(2) Logs can be assembled on a preloader by rolling by hand, by a jammer, by a grapple, or by a crane. A special jammer built for assembling loads and then lifting the front end of the load while the truck backs under is shown in 2, figure 7-19. This machine assembles the load from the log yard. It uses two tong lines, each attached to a separate winch. It is possible to move the tree lengths around from almost any position and place them in front of the preloader with one end resting on the crosspiece between the boom legs and the other on the ground. When a load has been assembled and a truck arrives, a wire rope sling with spliced eyes at both ends is passed under the front end of the load and hooked onto the two prongs of the front tong. Then the line going to this tong is tightened, raising the front end of the load so that the truck can back under it. The load is eased down onto the front bunk. The cable can then be removed and the load secured to the truck.

e. *Wire Rope Used for Loaders.*

(1) In all loaders that pick up the log and swing it through the air, special attention should be given to the wire rope and the sheaves and

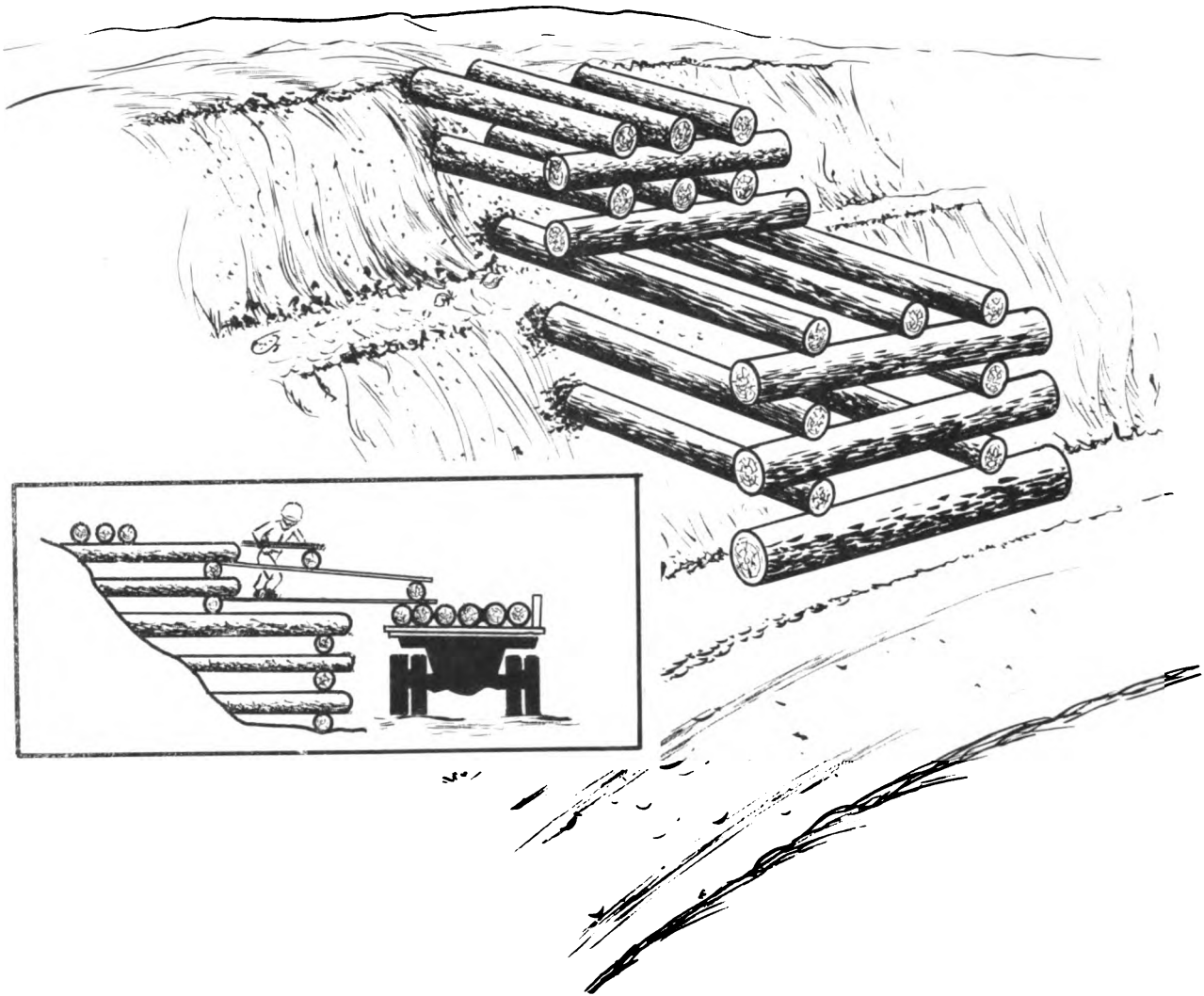

Figure 7-16. Double-deck skidway.

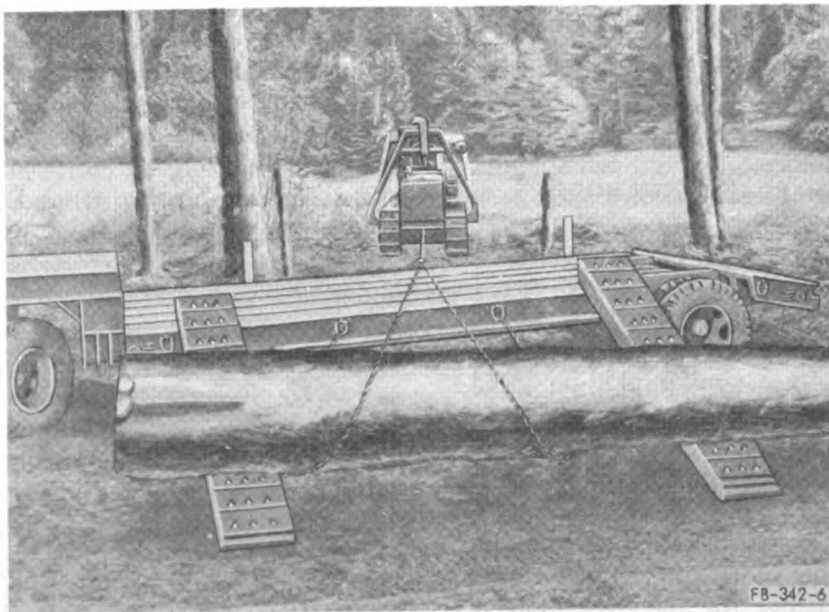
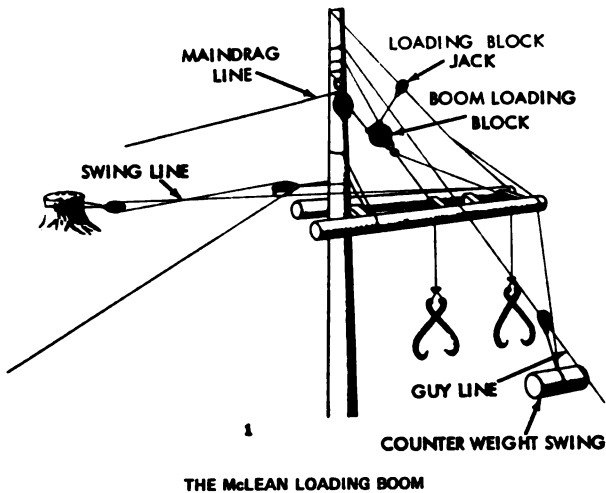
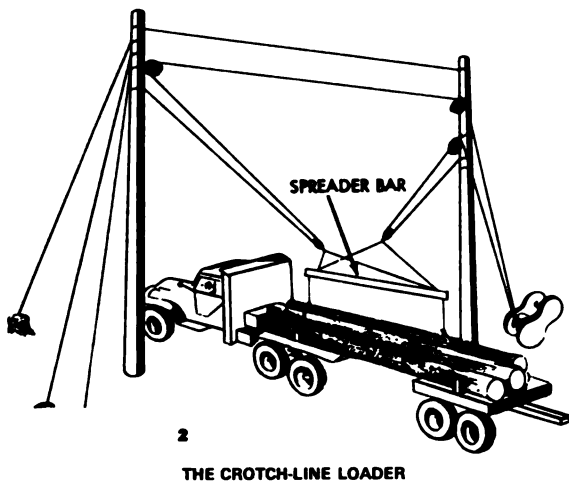

Figure 7-17. Cross-haul method of loading sawlogs.



1 THE McLEAN LOADING BOOM



2 THE CROTCH-LINE LOADER

Figure 7-18. Loading devices.

fittings used with it. For economy, speed, and safety, wire rope of adequate strength should be used, together with the proper fittings. Clips to fasten wire rope should not be used on loaders, particularly on live lines, because they cannot be expected to feed through sheaves properly, or to develop sufficient strength for lead and swing lines. Blocks of the right design and of sufficient diameter should be used.

(2) Wire rope on loaders is often subject to many jerks. Consequently, it is best to use 6 by 10 preformed plow-steel rope (TM 5-725) of a diameter that will carry the intended loads with an ample safety factor. It should be lubricated frequently and thoroughly. Special care should be given to spooling it evenly on the drums, making sure that it is not subject to unnecessary abrasion in blocks and sheaves. Periodic and careful inspections should be made of all rope in use. Kinked, badly abraded, crushed, or nicked rope

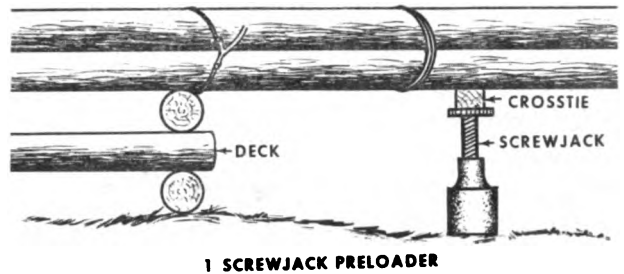

1 SCREWJACK PRELOADER

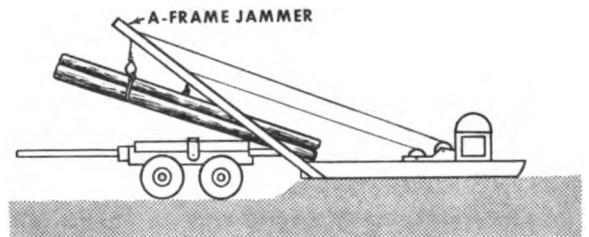

2 JAMMER PRELOADER

Figure 7-19. Preloaders.

should be cut out and discarded, or put to some less important and less dangerous use.

7-9. Unloading Logs

a. Long logs usually are unloaded by driving the load up alongside the landing place or pond on a tilt, releasing the stakes or bindings, and letting the logs roll sideways off the bunks. As a rule some of the logs must be rolled off with a cant hook. With long logs, a level landing bed is advisable to prevent breakage. Level dirt provides a springy landing, if it does not contain rocks. Where there is a steep slope down to a log pond, a permanent rollway of round or square timbers at a decided angle is more satisfactory, since it keeps the rolling logs from undermining the rollway and carrying dirt into the pond.

b. Where space is limited, and there is no pond, logs are frequently decked in the yard by a crane, crotch line (2, fig 7-18), grapple, or A-frame (fig 7-14) high-lead. Usually they are dumped off the trucks and picked up by the device being used, but in some cases they are picked off the truck bunks either individually or in bundles.

c. Another system of unloading is to use a crawler tractor with an improvised pushing device

mounted on the front end. This device is mounted similar to a bulldozer blade and consists of three or four steel rails welded vertically to the horizontal blade support.

7-10. Movement of Logs by Water

The use of waterways provides the least expensive way of moving logs from the forest. Wherever possible, this method of moving logs should always be considered, especially if the timber stand is located in an isolated place.

a. Floatable Species. In general, softwood species float and hardwood species tend to sink. This is not always the case, so it should be determined whether each species to be cut is floatable. A good method is to cut one of the trees and see if it will float. In many instances it is possible to float non-floatable logs by mixing them in rafts with floatable species.

b. Swift-Running Streams. In mountainous areas swift-running streams fed by melting snow and seasonal rains can be used if there are not too many rapids and short turns. If the water level in the stream changes rapidly, the depth and width of the stream will be affected and many logs will be stranded and lost. The chief advantage of moving logs along streams is that it alleviates the need for building skid roads and, in most instances, lessens the time required for moving the logs from the forest to the mill. Disadvantages are the losses due to sinking, stranding along the banks and in marshy areas, and breakage in jams and on obstructions encountered in the streambed.

The best criterion for the use of swift-running streams is to investigate whether or not the streams have been used in the past for driving logs. Since stream driving is the cheapest method of moving logs it would have been used if at all feasible. In the absence of local information, the decision on the use of the stream will be the responsibility of the person in charge of the logging operation.

c. Slow-Moving Rivers. In the delta areas of nearly every continent, particularly in the tropical and semitropical countries, the forests are transversed by wide, slow-moving rivers. The typical land areas are low, densely vegetated swamps or marshlands. Roadbuilding through these areas is a slow and costly process because of the insecure ground and dense vegetation. Log rafts can be made up at convenient points along the river and towed to the mill site or loading dock. The rafts should be bound together with wire rope or chains. The towing line between the raft and the towing vessel (usually a light bridge-erection boat) should be long enough to allow for full maneuverability of the boat. Also, the towing line should be attached to the boat in such a manner as to allow for quick detachment in case an emergency should arise warranting release of the load.

7-11. Wet Storage

a. Size of Wet-Storage Area. About 150,000 board feet can be floated per acre of pond. Non-floating logs should not be stored in large wet-storage ponds as recovery of sunken logs is a difficult and time-consuming job.

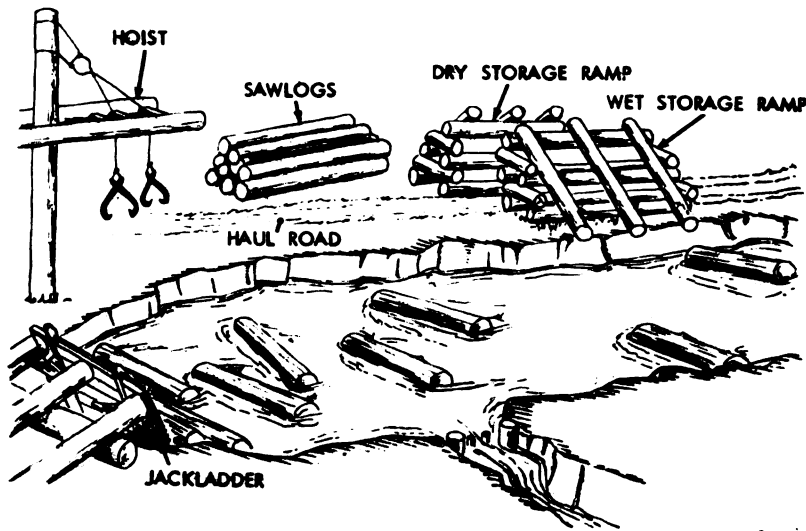

FB-342-16

Figure 7-20. Wet-storage facility.

b. Types of Wet-Storage Facilities. Streams, lakes, ponds, or log troughs can be used for wet storage. Usually it is best to use an existing facility since the construction of a dam for a pond or an excavation for a log trough can develop into an expensive and lengthy operation. In areas of extreme cold, wet storage can become a serious problem when ice forms over the storage area. Facilities for artificial warming or mechanical icebreaking must be considered during the planning for the sawmill site. Also, if mostly nonfloating timber is to be sawed, a deep or large area storage pond can create a problem in log removal.

c. Log-Handling Facilities.

(1) The wet-storage area (fig 7-20) must be situated so that the log-hauling trucks can approach and leave the unloading ramp without difficulty. If possible, the unloading ramp should be planned to extend along one side of the pond so that a dry-storage ramp can be built along the opposite side, parallel to the wet storage ramp. Planning the log storage yard in this way will facilitate the handling of logs intended for either dry or wet storage.

(2) Relatively small ponds holding only a few hours' supply of logs for the sawmill are used for species that sink as well as floaters. The purposes of this ponding are to wash grit and abrasives from the logs, thaw frozen logs, and provide a practical means of separating and feeding logs to the mill. Such ponds are either blocked off from larger water bodies or are constructed at the mill-site. These ponds must have a stable water level, a size small enough so that all logs can be reached from the margin with long pike poles, a depth limited to adequate log floatage, and a length to contain the required log volume. For logs not more than 16 feet in length, a 20-foot width, a 5-foot depth, and a length of between 50 and 150 feet will usually suffice for a small sawmill operation. The sides of the pond should be vertical and stabilized by cribbing, planking, or concrete construction. A spillway should be planned that safely carries off excess water. Another requirement is a gate or outlet pipes for draining when the pond needs cleaning.

(3) Logs can be conveyed from the pond to the log deck (platform by sawmill upon which logs are collected and stored previous to placing them on the sawmill carriage for sawing) by means of trams, conveyer chains, boom hoists, or sling chains. A simple device suited for small-mill production is a jackladder (fig 7-21). It hoists the logs sidewise from the pond to the deck. The jack-

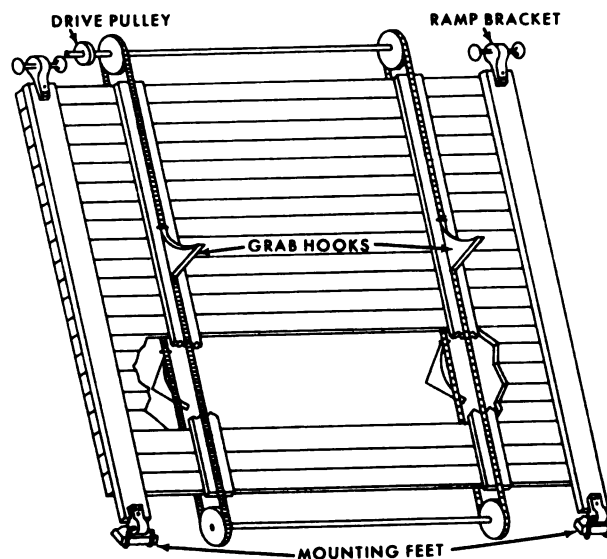

Figure 7-21. Jackladder.

ladder must be firmly anchored at the base by piling or a concrete slab and secured at the top of the log ramp as in figure 7-20.

7-12. Movement of Logs by Chute or Flume

The use of the log chute or flume is generally determined by the volume and size of logs to be removed from the forest, and by terrain features. In considering the use of the chute or flume, an analysis is made of the expense (manpower, man-hours, and materials) of installing the system. Usually it will be found that construction of a cable logging system or skid road system will be less expensive. However, there are situations that require the use of a chute or flume and these should be considered in planning every logging operation.

a. Chute. There are two classes of chutes: the trailing chute, and the gravity or running chute. If the grade is sufficient to allow the logs to slide down the chute unassisted, it is a gravity chute. If the grade is insufficient to allow the logs to slide of their own weight, it is a trailing chute.

(1) *Trailing chute.* As shown in 1, figure 7-22, the trailing chute is of simple construction, laid on the surface of the ground. The construction of the chute depends upon the type of log to be transported. The heavier the log, the heavier the construction of the chute. The chief disadvantage of the trailing chute is that some sort of road must be constructed to accommodate the towing vehicle or animal. The trailing chute might best

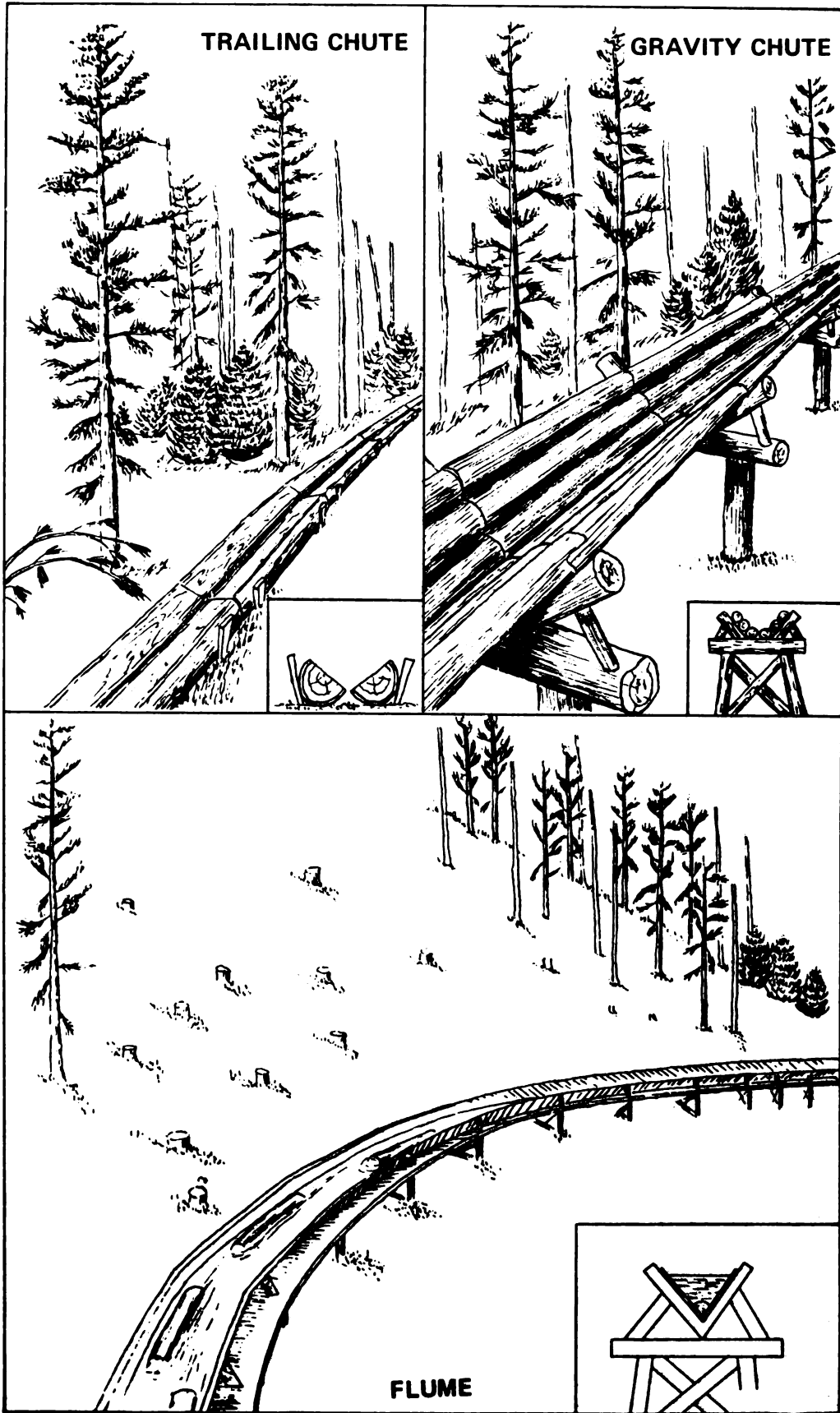

Figure 7-22. Chutes and flumes.

be utilized by indigenous personnel using their own motive power, such as oxen or horses.

(2) *Gravity chute.* The construction of the gravity chute (2, fig 7-22) may resemble the trailing chute (1, fig 7-22) since each is designed to avoid rough terrain and maintain proper grade. The depth of the trough depends upon the size of the logs to be transported. All curves built into the chute are gradual and the depth of the trough generally is increased on curves to prevent swiftly moving logs from leaving the chute. The grade maintained on chutes should be within a 10 to 35 percent range. A chute should be constructed of the least desirable species of trees and the bark should be peeled to decrease rot, friction, and snagging. In summary, the gravity chute can be used to excellent advantage over short stretches of extremely rough terrain, but if a lengthy chute is constructed its engineering requirement may far exceed that of the skid road or cable system.

b. Flume. The flume (3, fig 7-22) has a limited use in most logging operations. Its use is confined to smaller logs and bolts. There must be an abundant source of water at its point of origin and the construction of the flume must be sound enough to hold the water throughout the flume's length. Unless there is already a flume in use in the area being logged, it is recommended that construction of a flume be avoided in a military operation.

7-13. Logging Under Unusual Conditions

The mechanized equipment supplied to the forestry team is generally adaptable to almost every climatic condition. Under certain extremes of climate, modifications of the equipment may be necessary such as the installation of snow plows on wheeled and tracked vehicles. Additional equipment is usually needed to cope with particular situations. An example of this is the use of a bridge-erection craft as the motive power for a log raft. Unit commanders can best meet unusual conditions by adopting the logging methods which are already in use in the area in which the military unit is located.

7-14. Safety in Handling and Transporting Logs

a. Skidding Crew.

(1) The tractor operator should be responsible for the condition of the rigging and not permit the use of chokers and winch lines with broken strands.

(2) All workers must be in the clear before the tractor or winch is moved.

(3) Lines on cable systems should not be guided with the hands while the line is being wound on the winch drum.

(4) The skidding-tractor operator should check the overhead guard (fig 7-1) daily to make certain that it has not been broken.

(5) The skidding-tractor operator should at all times be alert to catch signals from the rigging slinger and to be positive that these signals are understood. Hand signals should be clear so that there is no chance for a mistaken meaning.

(6) When skidding off a steep slope, the rigging slinger must be in the clear, especially when pulling at an angle, since such a pull has a tendency to roll the logs.

(7) If, in the judgment of the tractor operator, the situation is not safe even though he has the signal from the rigging slinger, he should not pull.

(8) Any logs which stick out into the skid road so that they interfere with the skidding should be taken out in the first drag (collection of logs, choked, and attached to a towing vehicle), if possible, to clear the road for safe skidding.

(9) When working in deep snow, it is hard to move fast in the brush, and the rigging slinger should set the hook in the choker and come back to the skid road before yarding the log.

(10) Under no circumstances should either the choker setter or the rigging slinger ride the drag.

(11) Choker setters and rigging slingers should not remain on or near the rear of the tractor and the drag while the winch is in use.

(12) Do not stand near the skid road while the tractor pan or tractor and drag pass. Unexpected action of the pan can only be avoided by standing completely clear of the skid road.

(13) If a crawler tractor must be left unattended on a slope, it should be turned so it will not be able to roll down the hill uncontrolled. Even though brakes are set, vibrations may loosen the ratchet.

(14) All mechanical failures should be repaired immediately. This includes breakage, poor performances, loose controls, or the presence of anything which may be a hazard to the skidding crew.

(15) If it is absolutely necessary for rigging men to ride the tractor, they should be permitted to ride on seats only and the operator should be

responsible for their safe riding position. Rigging men should not get on or off the tractor while it is moving.

b. Loading Equipment Operator.

- (1) Only an authorized and trained person should operate any loading equipment.
- (2) All cables should be inspected daily and all defects corrected.
- (3) At least three wraps of hoist line should be on the drum before any heavy pull is made.
- (4) The engine should be shut off during servicing or repair, except for adjustment or diagnosing of trouble.
- (5) Equipment windows should be kept clean at all times.

c. Hookers or Tong Setters.

- (1) The hooker nearest the loading equipment should give all signals to the operator (except those the truckdriver must give to put the log in its proper notch). When the hooker is out of sight of the operator, he should transmit signals through the other hooker or truckdriver.
- (2) The hooker nearest the loading equipment hooks his end of the log last and indicates to the operator when the log is to be hoisted.
- (3) Activity involved in unhooking chokers or hoisting logs should be confined to one side of the load at a time.
- (4) No work should be permitted while a load of logs is leaving the landing.
- (5) No logs should be hoisted while the skidding tractor is pulling loose from the drag.
- (6) Hookers should concentrate on the log while it is being transferred from the drag to its notch on the load.
- (7) No logs should be hoisted while the knot bumper (limber) is limbing the logs on the drag.
- (8) The landing crew should keep the landing clear of all chunks, logs, limbs; and debris.
- (9) Where running lines are used, they should be placed in such a position that men are not in the bight of the line.
- (10) If a log must be guided, a handline should be used and controlled from the ground to one side.
- (11) Personnel should not stand so that logs will be swung over their heads.
- (12) Personnel should stand in the clear when trucks are being spotted.

d. Truckdrivers.

- (1) The truckdriver or top loader is responsible for the loading operation. The loading equipment operator must place the log where the truckdriver or top loader indicates.
- (2) Logging trucks and trailers should be equipped with stake bunks or bunks with chockblocks or both, at a height of at least 8 inches above the edge of bunk. Chains of sufficient strength to withstand the maximum imposed impact should be used. The gear should be so constructed that the chockblock can be released from the opposite end of the bunk.
- (3) Not less than two binders should be used on each load when transporting on public highways.
- (4) Logging trucks should be loaded in pyramidal form so that the center of the outside logs of each succeeding tier is inside the center of the outside log of the tier below. If stakes are used, the pyramid should start with the first tier above the top of the stakes. The load should be stable without binders and well balanced over the center of the bunks.
- (5) When trailers are loaded on trucks for the return trip to the woods, they should be securely fastened to the truckbed rather than being pulled behind the trucks. No truck with trailer loaded or a high load of logs should be backed without a signal from the head loader, or some member of the landing crew, because the trailer or load of logs interferes with the driver's view.
- (6) Logging trucks and trailers should be equipped with brakes that will safely stop and hold the maximum load on all steep grades.
- (7) All trucks and trailer units should be equipped with standard lights, horn, flags, flares, fire extinguishers, and so on, to conform to state motor vehicle laws. In case of an accident or breakdown involving a truck, flags or flares should be immediately set out as the condition of daylight or darkness requires.
- (8) Truck tires worn beyond a point of safety should not be used.
- (9) While loading, no person other than the top loader or truckdriver should be on the truck.
- (10) No loose tools or equipment should be carried inside the vehicle.
- (11) The horn should be sounded when a load is leaving the landing.
- (12) Drivers should not unhook or loosen wrappers before the unloading line is tight.

Section II. GRAPPLE YARDING

7-15. Introduction

A recently developed logging technique uses a grapple (fig 7-23) to transport logs to a main road or directly to the mill. The grapple may be attached to a running skyline, crane, tractor, or truck. The grapple takes the place of chokers in skyline grapple yarding. Figure 7-24 shows a typical logging grapple and carriage attached to a running skyline. Figure 7-25 shows a typical three-line running skyline rigged for grapple yarding. Figure 7-26 shows grapple yarding with the running skyline.

7-16. Advantages of the Grapple

a. *Skyline Grapple Yarding.* Grapple yarding

increases production, decreases the cost of lumbering, requires fewer personnel, and is less dangerous. It requires no chokermen, rigging slingers, or chasers, which are hazardous jobs. The spotter is able to stay a safe distance from running lines and has ample time to move safely from one position to another. He can direct the operator by voice radio communications, which improves efficiency. The operator can land logs at the roadside for convenient pickup without being concerned about a chaser being in a hazardous area. Grapple yarding saves both time and wood. Since it holds the log close to the rigging, fewer logs are lost or broken than in choker logging. Logs can be windrowed along the road to make the loading

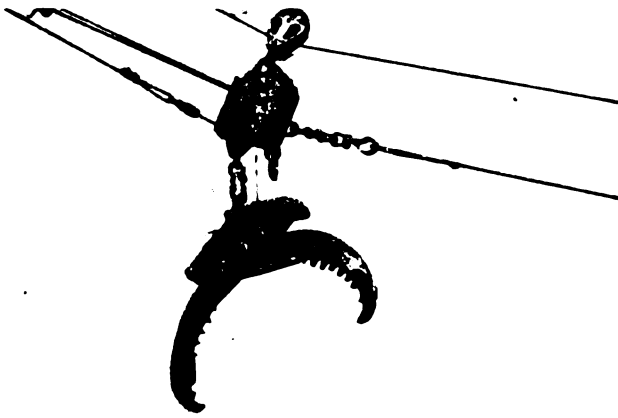

Figure 7-23. The grapple.

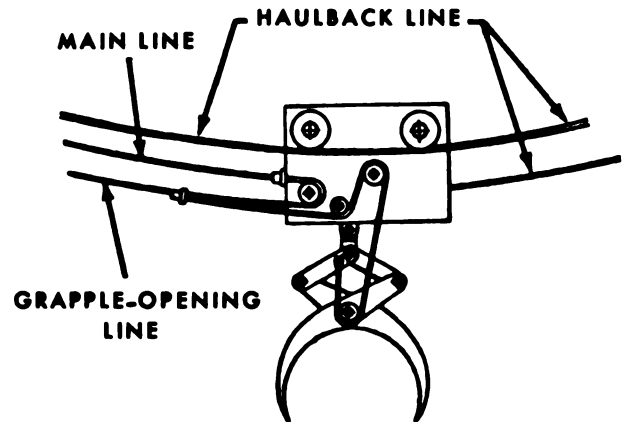

Figure 7-24. Logging grapple and carriage.

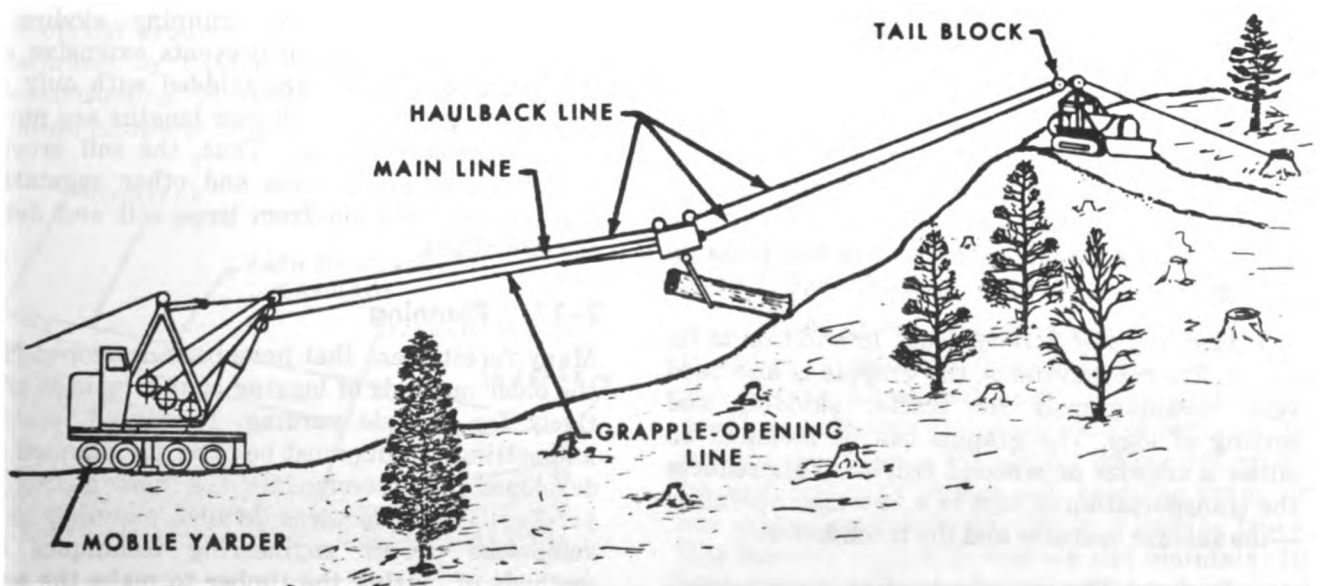

Figure 7-25. Typical three-line running skyline rigged for grapple yarding.

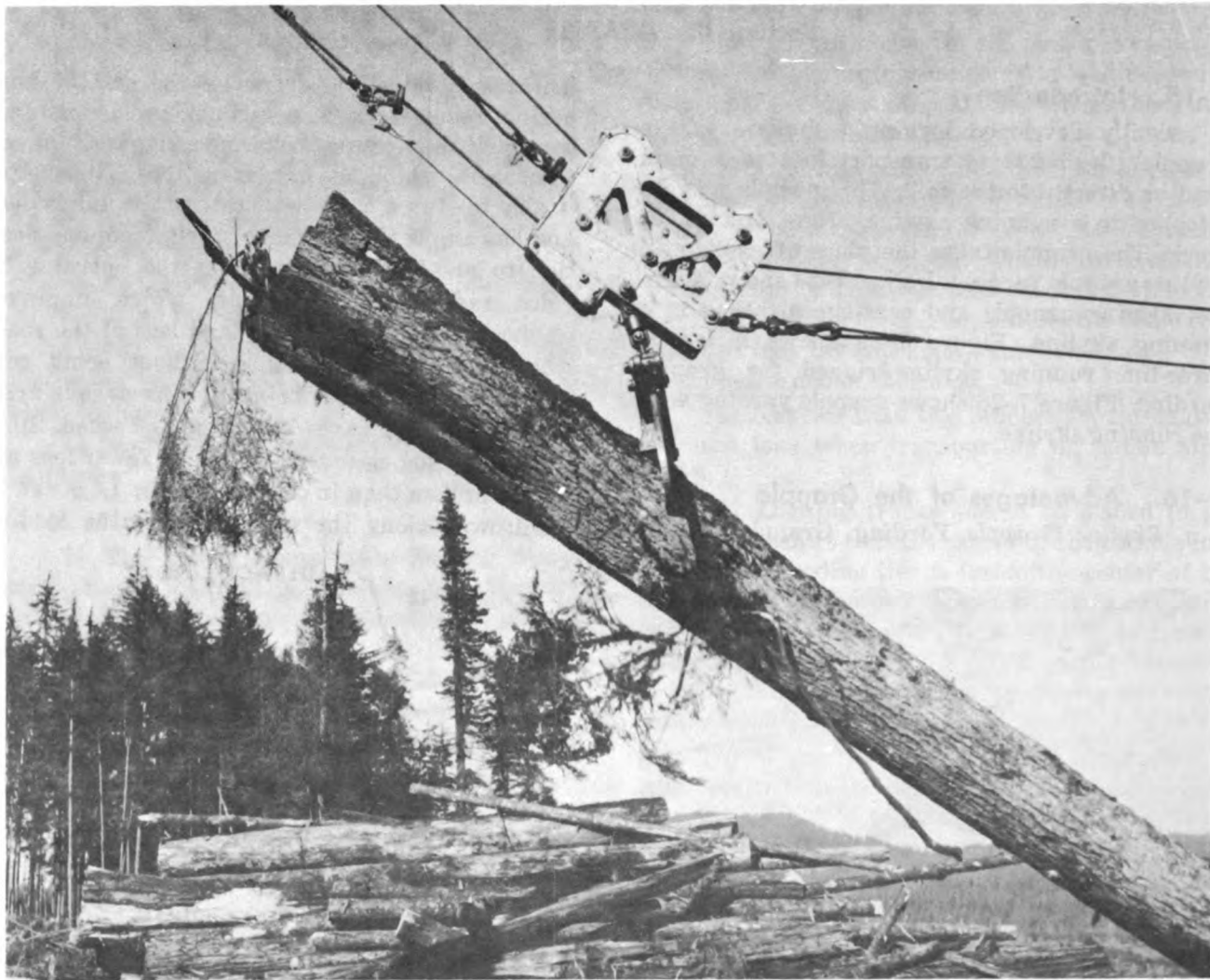

Figure 7-26. Grapple yarding with running skyline.

easier and faster. The trucks can be used more efficiently because they can be scheduled according to the requirements of the loader with no interference from the yarding operation. Grapple yarding is safer and more efficient than choker yarding in deep snow because no people are required to work with and around rigging. The grapple simply reaches into the snow and picks up the logs.

b. Skidding and Sorting Logs. In addition to its use on line cable systems, the grapple is also used very advantageously for tractor skidding and sorting of logs. The grapple can be mounted on either a crawler or wheeled tractor. This reduces the transportation of logs to a two-man operation—the skidder operator and the truckdriver.

c. Ecology. The grapple yarding system minimizes soil disturbance on both the uphill and

downhill operations. The running skyline is moved frequently, which prevents extensive erosion. Tree-length logs are skidded with only one end on the ground and shorter lengths are moved with no ground contact. Thus, the soil erosion, damage to standing trees and other vegetation, and stream pollution from loose soil and debris are minimized.

7-17. Planning

Many forest areas that have been developed from the older methods of logging cannot be used effectively for grapple yarding. New road locations and setting layouts must be carefully planned and developed to accommodate the new method of yarding. It also requires detailed planning to develop the proper engineering techniques and methods of cutting the timber to make the areas practical for grapple yarding and loading. Consid-

erable attention must be given to training crews for the entire grapple yarding operation.

a. Difference in Operation. Grapple yarding differs from the conventional high-lead logging in offering more options. For example, high-lead logging is usually done with a fixed landing and a movable tailblock, whereas the mobile grapple yarder has the following options:

(1) Move the tailblock around the landing, which reduces the average yarding distance to $\frac{2}{3}$ of the external distance (from the loading to the farthest point within the cutting boundary).

(2) Move around the tailblock.

(3) Move the tailblock and landing together in a series of parallel settings. Generally, the most efficient arrangement is parallel settings used in combination with a movable tailblock.

b. Deflection. In planning high-lead logging, deflection from suspended lines is generally ignored. Grapple yarding, on the other hand, is a specialized form of skyline logging in which deflection must be considered. In laying out a grapple yarding system (fig 7-27), adequate deflection must be provided to carry the weight of the lines, the carriage, and grapple over the logs. The minimum condition is where deflection is barely enough to position the grapple above the logs. Under this condition the system would provide insufficient lift to the logs and therefore should be avoided. A preferable deflection is to locate the landing tailblock so it will lift the front of the logs. The grapple system has the ability to suspend all or part of the weight of the load. The determination as to whether a grapple system can suspend a log free of the ground for a given setting may be determined by trial and error. This method is time-consuming. To remedy this, a desk-top combination computer and plotter has been developed

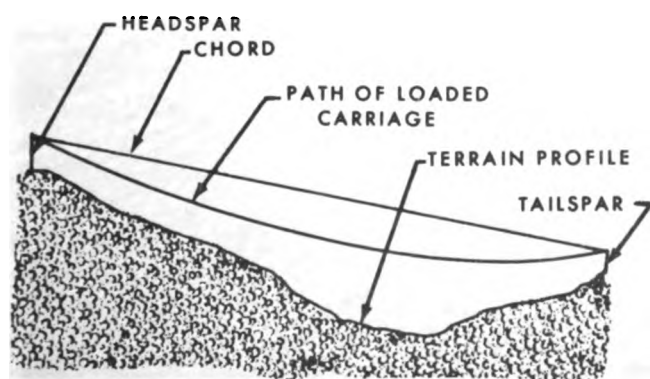

Figure 7-27. Typical profile plot of a grapple yarding layout.

which solves this problem of grapple yarding with running skylines. Its use requires no prior knowledge of special mathematics or computer programming.

7-18. The Grapple Carriage

There are several types of grapple carriages in use which are characterized as either mechanical or radio controlled.

a. Mechanical Carriages. The mechanical carriages (fig 7-24) in use contain sheaves and lines which are controlled from the yarder. They are a three-line apparatus which operates from split drums.

b. Radio-Controlled Grapple Carriage System.

(1) Several radio-controlled carriage cable grapple systems have been developed. One system is an electrical power unit where one motor opens the grapple; it closes by gravity. A second motor orbits the grapple.

(2) Another type of radio-controlled carriage uses air to open the grapple. Air is supplied by a compressor run off the skyline sheave on the carriage.

(3) A third carriage is built with a clamp and a split drum on the skyline and is controlled by a truck brake. The skidding line is wrapped around the drum and the tong line is wrapped on the other side of the drum and then threaded through the grapple. To open the grapple, the clamp is applied to the skyline and the truck brake is released with the skidding line slack. The weight of the grapple pulls the slack through and allows the grapple to open. The truck brake is applied, which keeps the grapple open on the trip back. When the grapple is over the log, the brake is released and the grapple closes. This unit has a constant pressure on the grapple while yarding which reduces the log damage.

7-19. The Yarding Crane

Figure 7-28 shows a yarding crane in operation. It seldom requires guylines or chokers and can be operated by a two-man team under almost any weather conditions and every type of terrain. The yarding crane can safely climb a 30 percent grade. Its undercarriage brakes will hold the crane on any grade that can be traveled by a logging truck. The machine is easy to operate and maintain. Its controls are air actuated for instant response and arranged for convenient operation.



Figure 7-28. Yarding crane.



Figure 7-29. Truck-mounted grapple.

7-20. Truck-Mounted Grapple

A popular grapple for small jobs which can be mounted on a truck in 2 hours or less is shown in figure 7-29. It has a lift capacity of 16,000 pounds.

7-21. Fork and Grapple Attachment

Figure 7-30 shows a special fork and grapple attachment designed to move and sort logs. A special notch or "frog" is designed into the fork so that the grapple can pull a log in and still have enough of the fork exposed (approximately 18 inches) for sorting. By using the exposed 18 inches, an operator can put a log on the end of the fork and flip it off with a reverse action of the top

clamp. When the machine is not used for sorting logs, the fork may be taken off and a blade or bucket attached for moving dirt or loading gravel.

7-22. Night Operations

Grapple yarding can be carried out effectively at night. A night shift increases the output and reduces the capital outlay for equipment. Approximately 5 foot-candles of illumination is enough for lighting the working area. This amount of light is obtained by using three 1000-watt mercury vapor lamps, or two 1000-watt metallic vapor lamps, or six 1500-watt quartz lights, or nine 1000-watt incandescent lamps in the logging area. The grapple and the carriage should be painted with reflective paint.

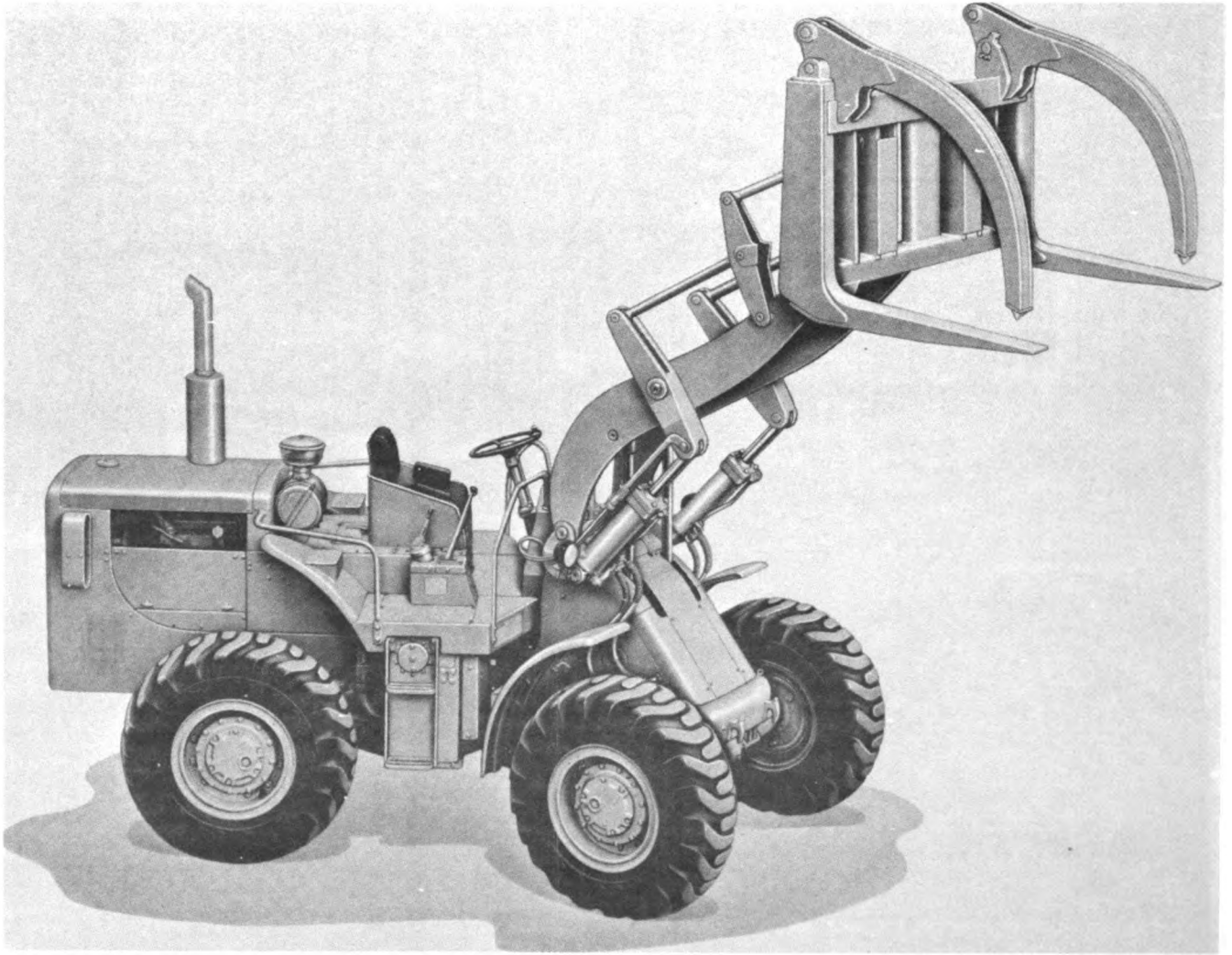

Figure 7-30. Fork and grapple attachment.

Section III. BALLOON AND HELICOPTER LOGGING

7-23. Introduction

Logging engineers have searched for years for a sky-hook to simplify logging problems, mainly for lifting logs out of inaccessible places and over obstructions. Experiments have been performed by commercial logging companies. Some of these projects were evaluated by the US Department of Agriculture as mechanically feasible, but perhaps too costly for general use.

7-24. Balloon Logging

a. A balloon logging system has been developed which employs a balloon to fly logs from inaccessible mountainsides to yarders at roadsides. The gases used as lifting agents are helium and ammonia, each involving very expensive charges for inflating the balloon. Another type of balloon which

is more feasible has been constructed to fly wood out of flooded (swamp) areas. The balloon is charged with hot air produced by a propane burner located at the bottom of the balloon. The balloon has a lifting capacity of 10,000 pounds. The cost of transportation per cord of wood is less than that of conventional harvesting systems.

b. Balloon logging may become feasible for commercial logging companies, but not for general military use because of the equipment. The special types of balloon are very expensive and too cumbersome for military use.

7-25. Helicopter Logging

Helicopter logging is still not a conventional method of logging, but useful criteria have been developed for situations in which it may be ad-

vantageous. Two main factors hinder this method at present—there is no specially designed helicopter for logging, and the cost of logging by this method is too high. This paragraph presents some additional information on helicopter logging.

a. Crew.

(1) *Two-man helicopter crew.* The pilot maneuvers the helicopter and the copilot monitors all instruments to assure that the aircraft is operating properly.

(2) *Ground crew.* One logging helicopter requires two fellers, five buckers, two chokermen, and one hooker.

b. Communication. Communication between the helicopter and the ground crew is carried on over a two-way radio.

c. Load Capacity. The load that can be transported depends on the size of the helicopter. The

average load flown is about 8,000 pounds. The largest helicopter hauls a payload of 20,000 pounds. The logs normally transported range from 16 to 32 feet in length and are about 3 feet in diameter. Logs as long as 48 feet and as thick as 56 inches can be flown.

d. Speed. The loaded helicopter delivers a log at a speed of about 40 miles per hour; the return flight to the logging area is made at about 60 miles per hour.

e. Slings. Military log transportation by helicopter will be done in accordance with the TM 55-450 series. Commercial logging companies have successfully transported logs by helicopter using 1/2-inch plow steel wire rope (TM 5-725).

f. Proplash. The wind velocity produced by the helicopter is about 70 miles per hour.

CHAPTER 8

SAWMILL EQUIPMENT

Section I. SAWMILL COMPONENTS

8-1. Introduction

This section describes and illustrates the major components of portable sawmills.

8-2. Headsaw

The headsaw is the saw which cuts the log into boards. The main types of headsaws in use are the circular and the sash-gang. Various arrangements of circular saws have been used including single-circular with or without a top saw, twin-circular, and gang-circular. The most common arrangement is the single circular without a top saw.

a. Circular Headsaw. The circular headsaw is the most common type of headsaw in use. It consists of a flat steel disk with the saw teeth cut around the circumference. The saw is mounted on a shaft to which power is applied. The log is cut into boards by successive passes through the saw.

b. Sash-Gang Headsaw. A sash-gang headsaw is a series of vertical reciprocating saw blades. As the log is fed through the saw it is cut entirely into boards on one pass. The sash-gang saw has a high cutting accuracy and recovers more lumber from each log than other headsaws. Its primary disadvantage is its inflexibility in cutting to various thicknesses.

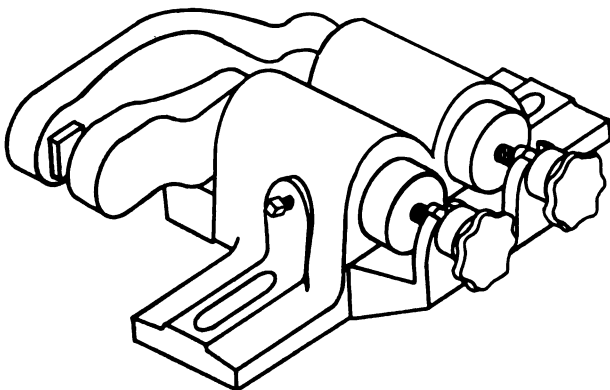

Figure 8-1. Headsaw guide.

8-3. Headsaw Guides

Headsaw guides (fig 8-1) are used on circular saws to steady the saw. The guide is mounted on the husk timber next to the track on the sawyer's side in either of two positions, depending on the size of saw used. The two wooden guide pins are mechanically adjustable and secured with a locking device. The saw guide, when properly adjusted, clears the saw by approximately 1/32 inch on both sides of the rim of the saw.

8-4. Husk and Mandrel

a. Husk. The husk is a box-like frame of wood or metal that supports working parts of a circular headsaw, including the mandrel and usually the feed-works mechanism. Two bearings are provided for mandrels up to 6 feet in length and additional ones are added for longer mandrels. Provision is usually made to fix the husk to supporting horizontal timbers, or sills, with bolted metal brackets. In some models, brackets are also used to hold the track and husk in a fixed relationship.

b. Mandrel. The mandrel is the mechanical, hardened steel shaft carrying the saw, several pulleys, and possibly a flywheel. The mandrel is commonly belt-driven but direct drives are also used. Clutches may be placed in the mandrel so that the saw can be shut down independently of other machines. The saw is clamped between a fixed saw collar sealed to the end of the mandrel and a loose collar held by big pins and bolted on the mandrel.

8-5. Carriages and Trackways

The carriage is a movable truck on which the log travels to the saw. The carriage consists of two main parts, the carriage frame with wheels and axles, and the superstructure by means of which the lateral movement of the log toward the saw is controlled. This superstructure may be either the

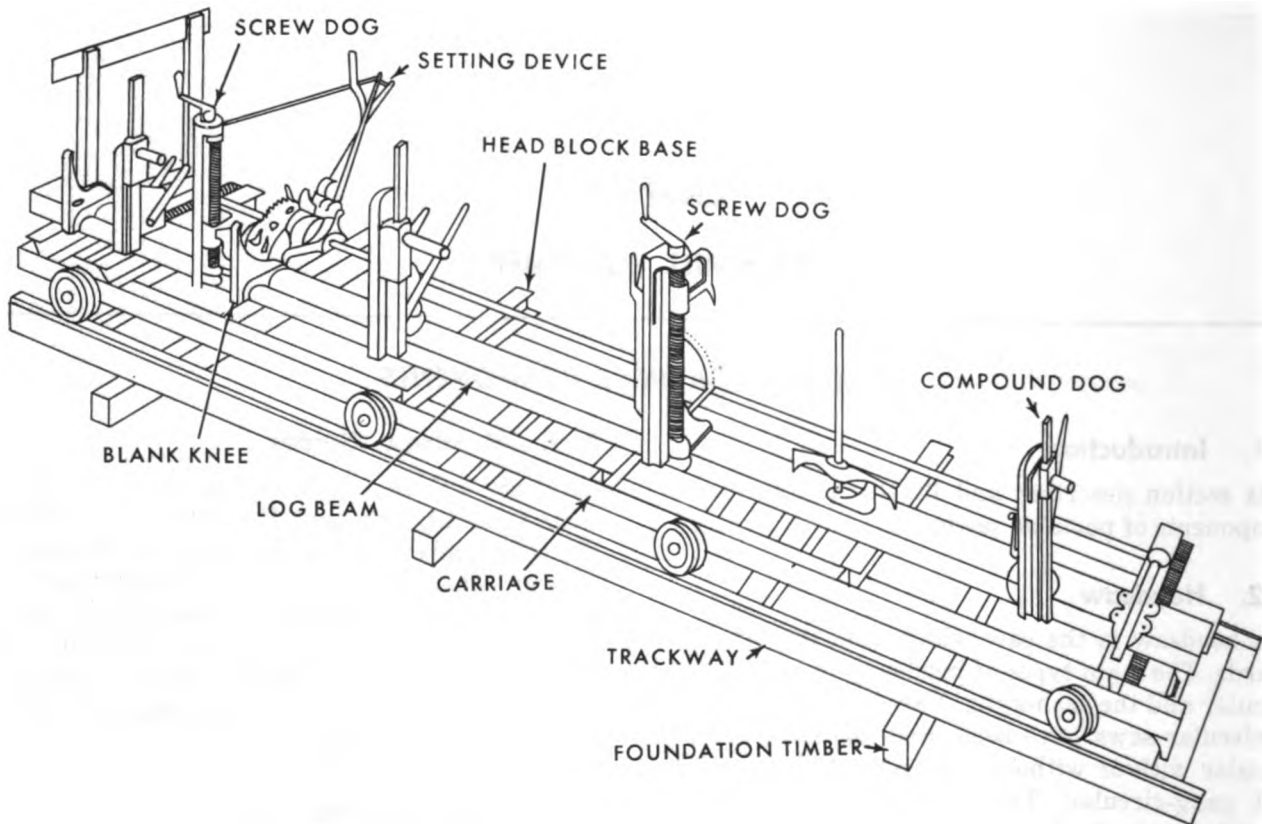

Figure 8-2. Log-beam type carriage.

log-beam or the headblock type. The carriage framing is of heavy timbers or metal beams. This framework is mounted on four heavy trucks and truck axles which work in roller bearings mounted on the under side of the framework. One wheel is usually pressed on each axle. These wheels are either ground or flanged so that side play of the carriage is eliminated.

a. Log-Beam Type. The log-beam mechanism (fig 8-2) operates on several bases made of light metal or timber beams. These beams are mounted on top of the carriage framework. The log-beam mechanism consists of a beam which extends the length of the carriage, and on this are mounted several knees of varying types to which are attached different kinds of dogs for holding logs and cants. The log-beam mechanism moves at right angles to the length and travel direction of the carriage thus pushing the log into the saw according to the thickness desired to be cut.

b. Headblock Type. The headblock type superstructure (fig 8-3) for the carriage consists of two or more bases fastened to the frame. In each base slides a knee; each knee is connected to a mechanism for pushing the log into the saw. With

this type only the knees move back and forth across the carriage.

8-6. Feed Works

Small-mill feed mechanisms, by which the sawyer controls the rate of log feed to the headsaw, are operated by straight friction; friction combined with belts and pulleys; belts and pulleys; belts, pulleys and clutches; gears and clutches; electric, hydraulic, or steam-piston drives. All may use the cable-over-drum or rack-and-pinion drives.

a. Straight Friction. In straight friction types, beveled plates powered by the mandrel operate a beveled friction wheel and shaft that rotate a disk continuously. By bringing the rim of a lever-actuated friction wheel into contact with this disk, motion is transmitted through shafts and gears to turn the drum and move the carriage. Reverse motion is obtained either by crossing the disk center with the friction wheel contact (1, fig 8-4) or by contacting the reverse face of the disk with a second friction wheel after breaking contact with the first one (2, fig 8-4).

b. Friction With Belts and Pulleys. In the types

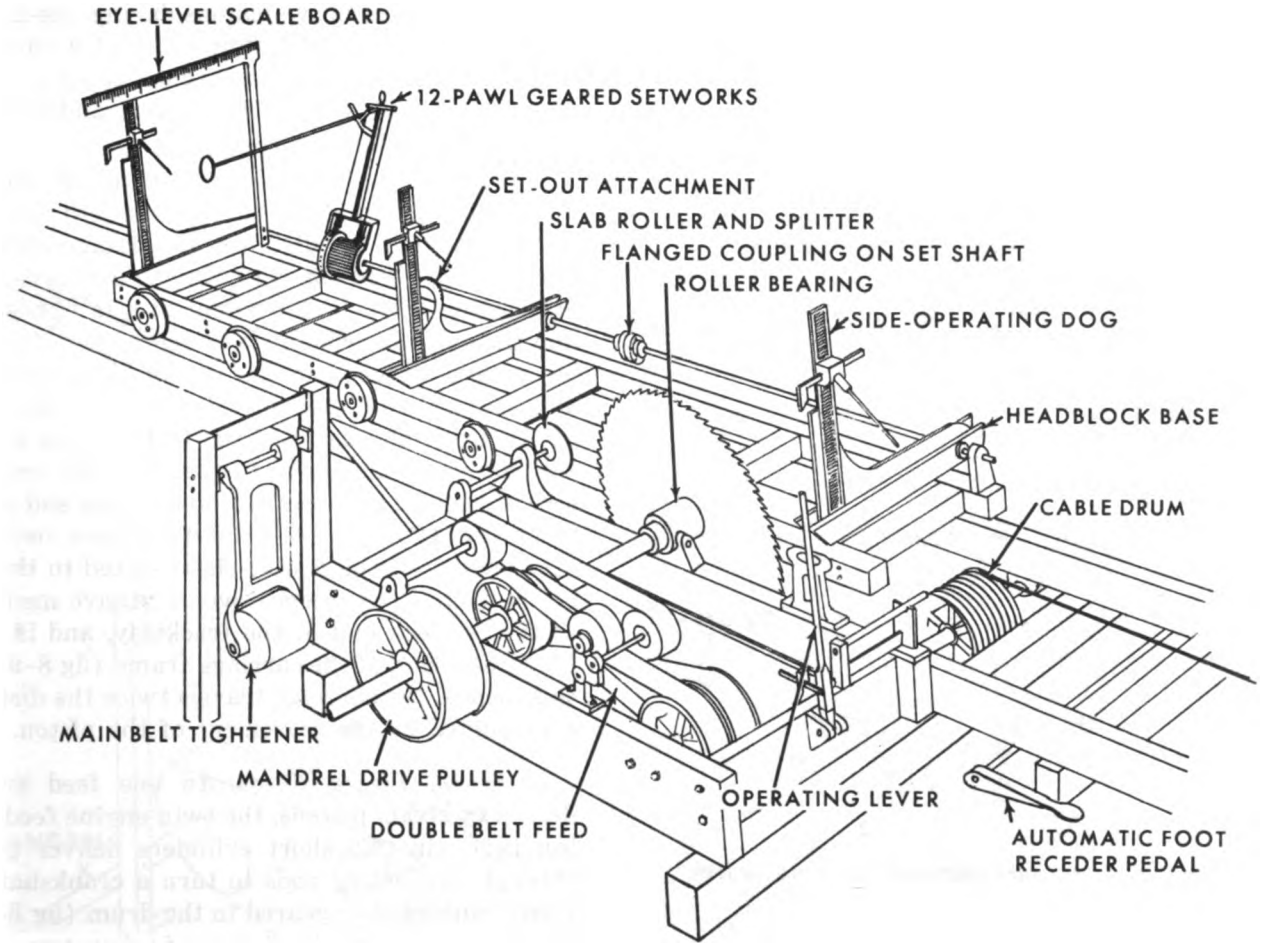

Figure 8-3. Headblock type sawmill.

employing friction with belts and pulleys, power is transmitted in one of three ways: (1) from a pulley or sprocket fixed to the mandrel through a belt or chain to a pulley or sprocket shafted to a friction wheel that is lever-actuated to contact a bull pulley shafted directly to the drum (1, 8-5); (2) from the drive pulley on the mandrel by belt to an intermediate pulley, which is shafted to a sprocket transmitting power through the chain to the drum shaft (2, fig 8-5); or (3) from the drive pulley on the mandrel by belt to a second pulley equipped with an enlarged hub and wide rim (3, fig 8-5). A friction pulley is placed between the hub and rim (3, fig 8-5) on a movable shaft connected to the drum. Feed action results from engaging the hub face while gig action results from engaging the inside of the rim. Both feed and gigback can be obtained by the feed works shown in 4, figure 8-5.

c. *Belts and Pulleys.* In the types employing belts and pulleys, the power for feeding the carriage is transmitted by belt from a pulley fixed to

the mandrel to a lever-actuated movable pulley ahead of the mandrel, and thence through a fixed pulley behind the mandrel and the fixed pulley on the drum shaft. Power for reverse motion is transmitted by belt from a second pulley fixed to the mandrel to a second pulley fixed to the drum shaft. A lever-actuated rider is so adjusted in a rocker arm frame that one belt can be tightened and the other loosened by moving the lever to feed or gig position, as desired (fig 8-6).

d. *Belts, Pulleys, and Clutch.* The type employing belts, pulleys, and a clutch has the same hookup as the type with belts and pulleys alone, but the belts are tight in order to rotate the two pulleys continuously on bearings about the drum shaft or a shaft geared to the drum shaft. Drive or gig is provided by contacting one disk or the other fixed to each of these pulleys with a corresponding disk fixed to lever-actuated pulleys sliding along a key seat on the drum shaft (fig 8-7).

e. *Gear and Clutch.* In the type operated with gears and clutch, power taken from the mandrel

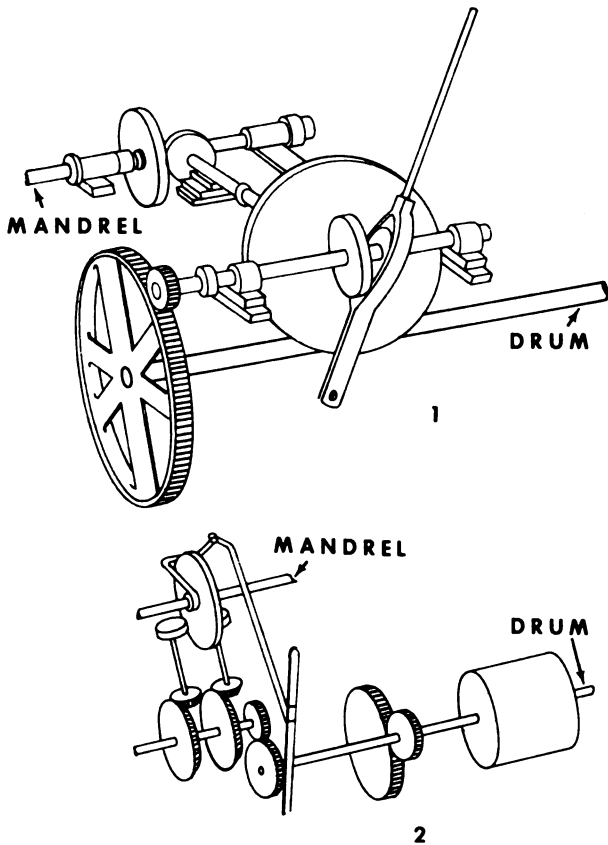

Figure 8-4. Straight friction types of feed works.

through chain sprockets drives a floating axle and, by means of planetary gears and a drum-brake mechanism, turns the drum shaft (fig 8-8). This has a lever-controlled brake and bevels on a split housing.

f. Electric Feeds. In electrically powered feeds, the drum is usually installed near the deck end of the track and a reversible direct current motor is connected to it. Rod connections from the sawyer's lever to the transformer control the direction of rotation and speed attained by the motor.

g. Hydraulic Feeds. Hydraulic feeds employ at least three variations in power transmissions: the turbine, the oil motor, and the single-piston.

(1) In the turbine, oil under pressure from power usually taken off the mandrel is forced through the turbine blades, thus turning a shaft connected to the drum.

(2) In the oil motor, a series of small pistons is radially placed on a rotating cylinder that is concentric with a fixed core that contains oil ducts. The piston heads are contained by an outer ring placed eccentrically to the core and free to turn on its axis. The inlet oil vents are so placed that oil under pressure is simultaneously forced

into several consecutive pistons during one-half of a complete cycle of the cylinder, and withdrawn during the other half of the cycle, and oil is closed from the circuit during the longest and shortest phase of the piston stroke.

(3) In the single-piston variant of the hydraulic feed, a cylinder having a length approximately one-half the distance of carriage travel is anchored between the rails. One end of a cable is attached to the cylinder mount at *a* in figure 8-9, and the cable is brought over one pulley of a double sheave attached to the end of the piston rod and over a second sheave anchored at the deck end of the track and thence fixed to the front end of the carriage frame at *b* of figure 8-9. One end of a second cable is anchored at the opposite end of the trackway (Point *e* of fig 8-9), passes over the other pulley of the double sheave fixed to the end of the piston rod, thence over a sheave anchored at the nondeck end of the trackway, and is fixed to the back end of the carriage frame (fig 8-9). By this means, the carriage travels twice the distance represented by the movement of the piston.

h. Steam Piston Feeds. In one feed system driven by steam pistons, the twin-engine feed, piston heads in two short cylinders deliver power through connecting rods to turn a crankshaft directly connected or geared to the drum (fig 8-10). In another system, the shotgun feed system, a piston head in a single cylinder that extends the full distance the carriage travels is connected by a piston rod directly to the carriage (fig 8-11). In the twin-engine feed, a lever controls the direction of rotation and size of valve opening. In the shotgun feed, the lever controls the intake and exhaust at each end of the cylinder so as to apply steam pressure to either face of the piston head and thereby advance or reverse the carriage.

8-7. Operating Features of Feed Works

a. In all except the steam piston, electric, and hydraulic types, the feed works is geared to recede the carriage about twice as fast as it advances it. On all types, the sawyer seeks to adjust the rate of advance to the load capacity of the saw or power source.

b. The rope-drive and single-cylinder feeds (hydraulic or steam) have the advantage that they can be centered on the carriage, thus minimizing strains in the frame. The rope-drive can be extended more readily to saw long logs than can the single-cylinder variant. The rack-and-pinion drive, applying the propelling force along the edge

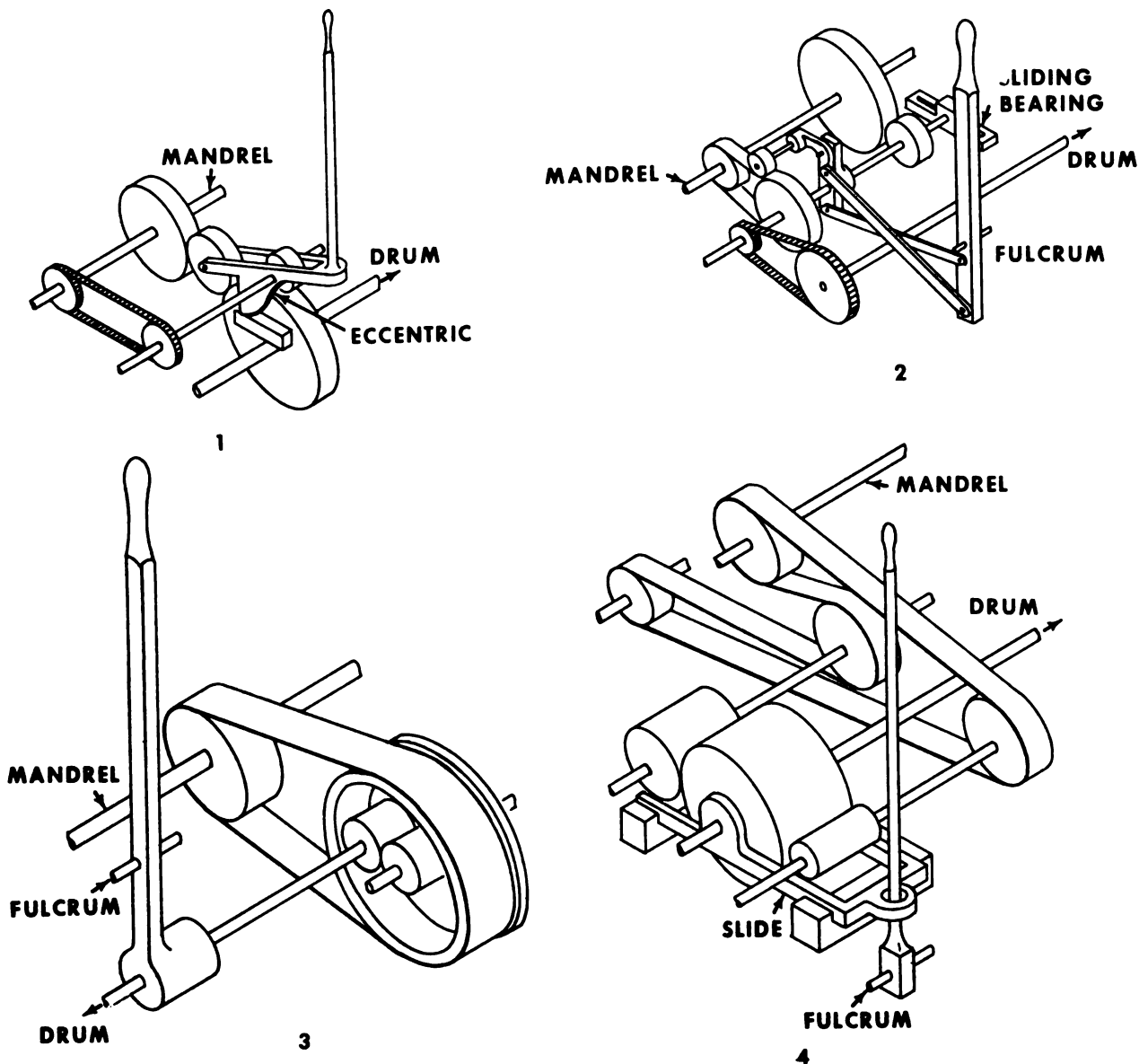

Figure 8-5. Friction-belt-pulley feed works.

of the carriage, is more subject to racking, and the carriage travel is limited by the length of the rack fixed to it. This drive therefore is less suited to cutting long logs.

c. In the straight friction mechanism, the braking action and power transmission are dependent upon the friction where the wheel and disk are tangent. Considerable leverage must be used, and the carriage is braked into reverse by holding the friction wheel in static contact with the moving disk, thus tending to wear flat spots in the friction wheel. Carriage reverse is normally sluggish. In the belt- and pulley-type, braking action and power transmission are dependent on the contact of belt and pulley over areas approximating one-

half the circumference of the pulley; consequently, wear is dispersed over a greater area, and a quicker response to the lever is possible. In the type employing friction, belts, and pulleys, the continuously rotating friction wheels tend to wear more uniformly and exert a quicker response than in the straight friction type. The type using belts, pulleys, and clutch and the planetary-gear type exert a quicker response and action than does the type using friction, belts, and pulleys. Moreover, they can be used where steam is not available, and are suited to mills producing 2,000 board feet or more per hour.

d. Steam piston, electric, and hydraulic types combine speed with excellent control, and are used

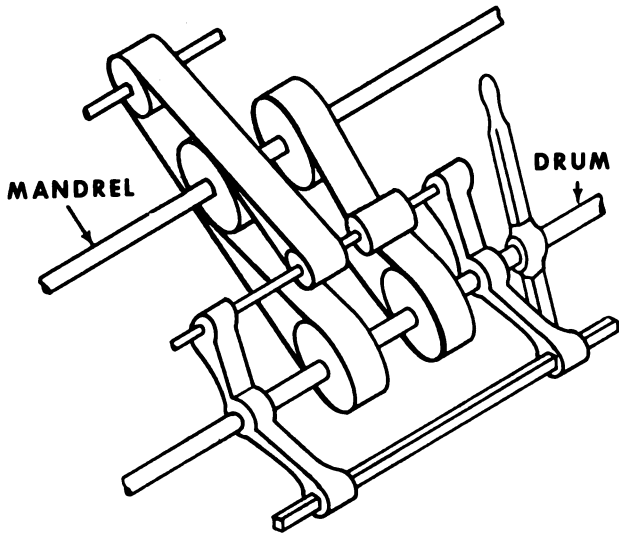

Figure 8-6. Belt-pulley feed works.

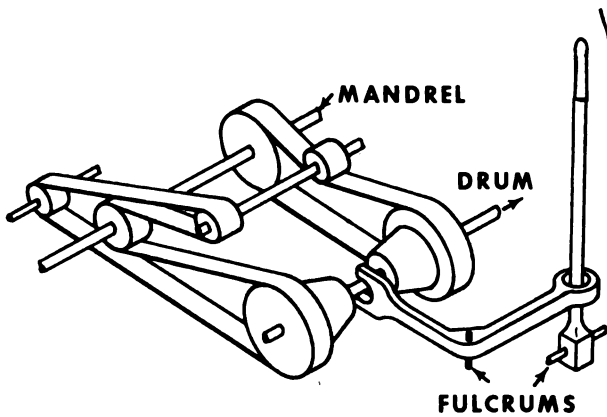

Figure 8-7. Belt-driven feed works with clutch.

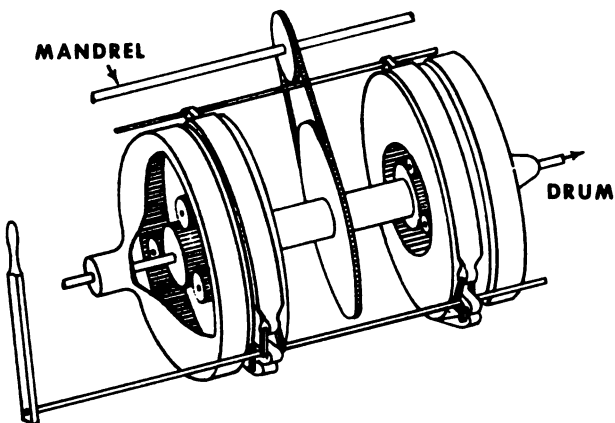

Figure 8-8. Chain-driven feed works with lever-controlled brake bevels on split housing.

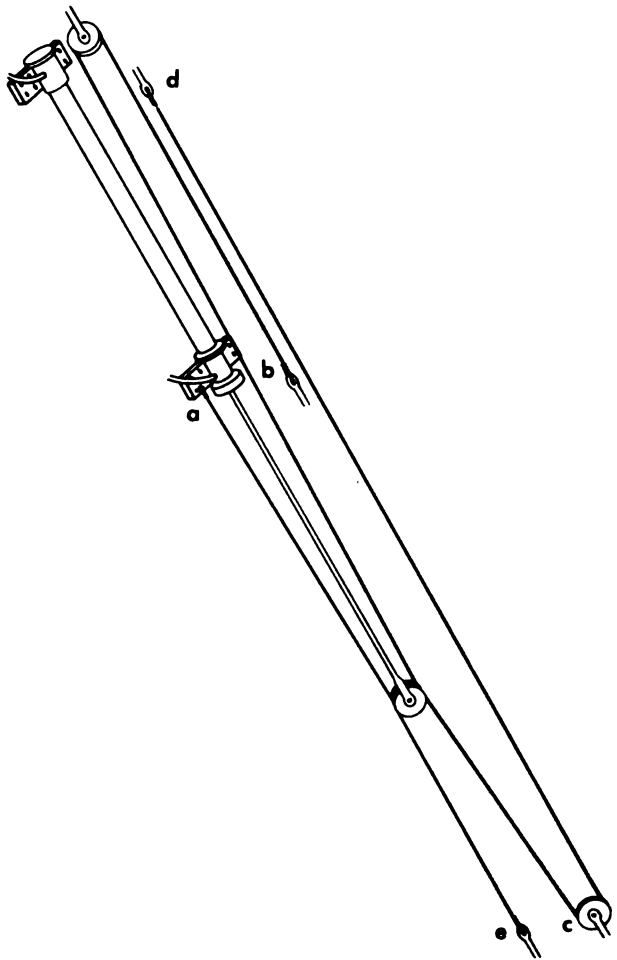

Figure 8-9. Hydraulic feed works.

mills with a capacity of 2,000 board feet or more per hour.

8-8. Dogs

Dogs are used on small mills to hold the log firmly on the carriage. They employ either a spike or a hook to grip the log, but the different types vary widely in mechanical details. The basic types are those using a fixed post with the spike attached or revolving about it; those with a sliding post; the hammer dog with spike arm and hammer moving through a fixed arc; and the "boss" dog with lever-actuated hooks thrusting out from the knees.

a. Fixed Post.

(1) Included in the fixed-post, manually operated types are those shown in figure 8-12. The rack variation (1, fig 8-12) consists of the spike and pinion wheel fixed to the dog housing and the rack machined or stamped into the fixed post. Pawls engaging the rack help keep the spike embedded as the pinion is turned when the lever

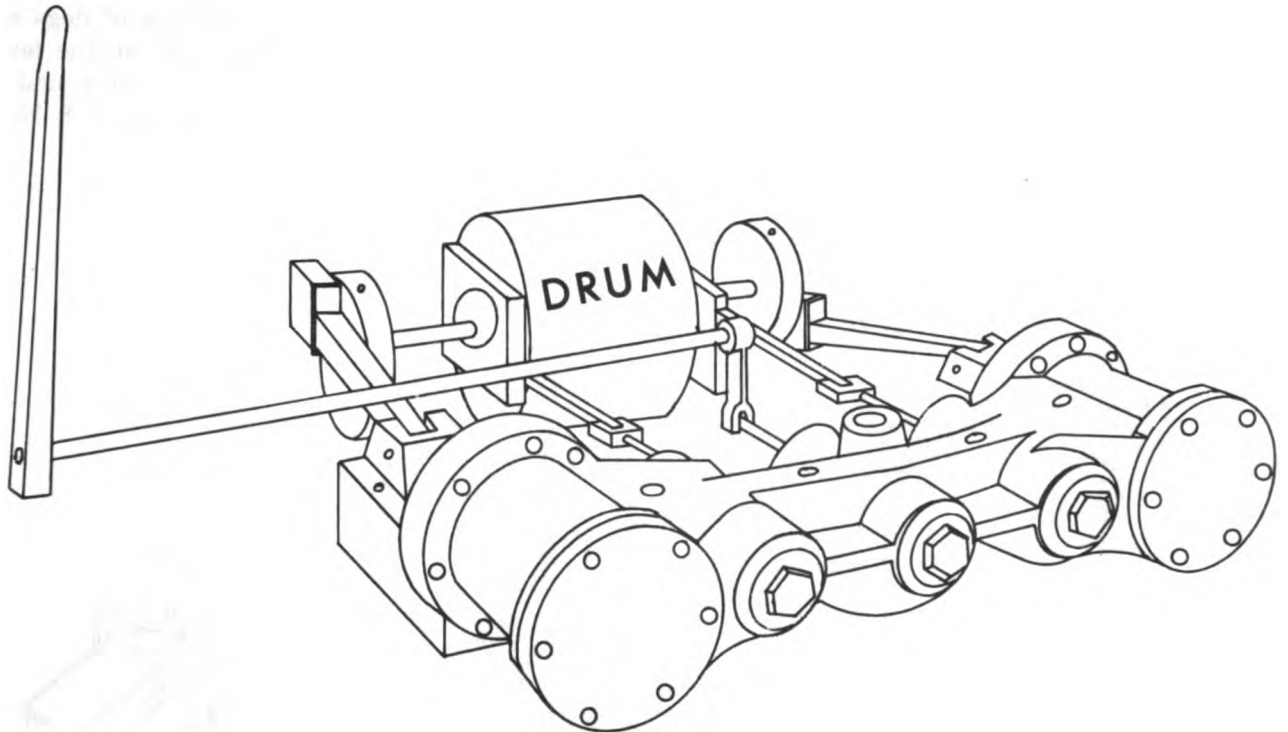

Figure 8-10. Two-cylinder steam feed works.

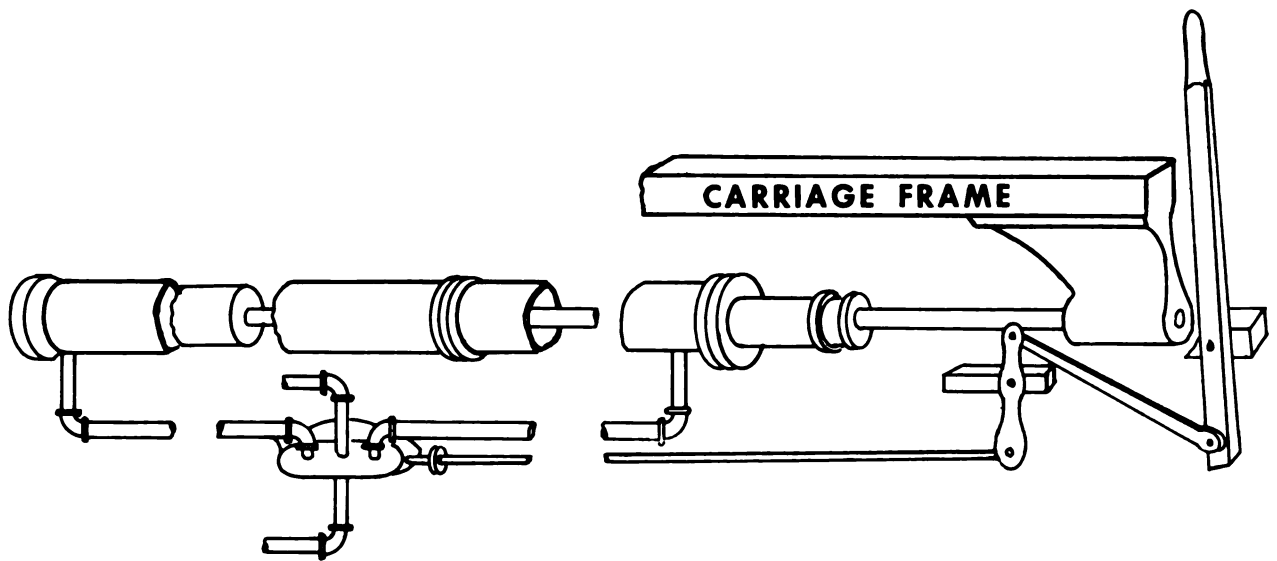

Figure 8-11. Single-cylinder steam piston feed works.

is pulled down. The dog shown in 2, figure 8-12 employs an eccentric to hold the housing to the post. In the threader post or screw dog (3, fig 8-12), the hooks are fastened to a housing threaded to the post. Pawls hold the housing in place or can be withdrawn to permit rapid lifting or lowering of housing. By turning the fixed post, the dog is raised or lowered as desired. The type of dog shown in 4, figure 8-12 consists of a spike at each end of unequal length lever arms that can

be rotated around to provide additional dogging for large logs. The weight of the dog is relied on to clinch the log properly.

(2) Fixed-post, power-operated dogs are actuated by air or hydraulic cylinders and electric motors. The air or hydraulic dog (5, fig 8-12) consists of a cylinder fixed to the spike housing with the piston rod anchored to the base of the dog. When the cylinder is actuated it pulls the dog into the log. The electric dogs have a chain at-

tached to the top and bottom of the spike housing and thence over sprockets propelled by the motor (6, fig 8-12). Provision to break the current at a definite load prevents strains on the assembly.

b. *Sliding Post.* Moving-post types of dogs are shown in figure 8-13. A down pull on the lever gives a downward movement of the spike, and in those illustrated in 3, 4, and 5 of figure 8-13 it

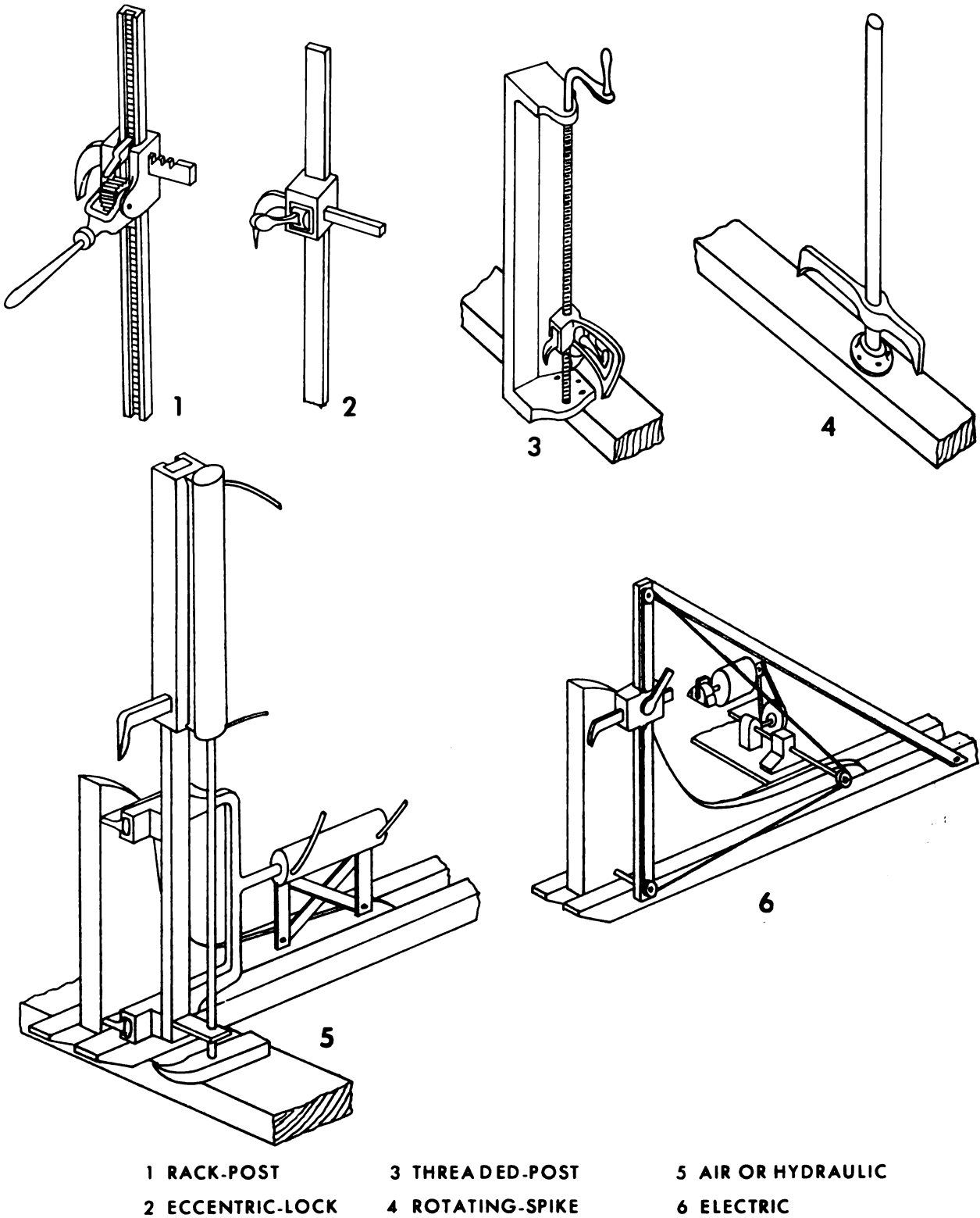

Figure 8-12. Fixed-post types of manually operated dogs.

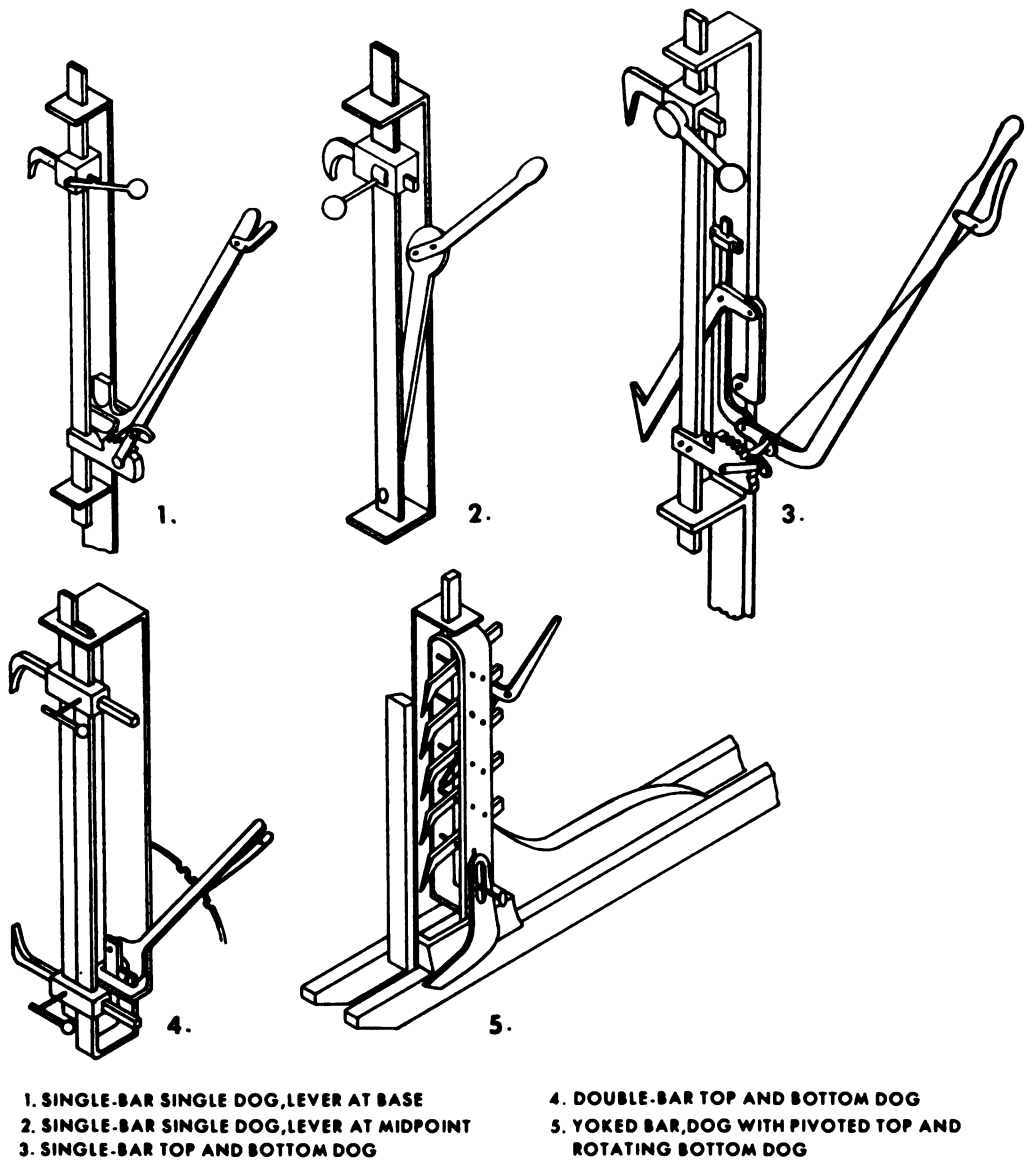

Figure 8-13. Housing-post types of manually operated dog.

also gives a simultaneous upward movement of the bottom dog.

c. Hammer Dog. The hammer dog (fig 8-14) is at the end of a radial arm; the opposite end is fixed to the knee. The hammer and lever are also pivoted at the same point, the hammer following the arc of the spike as the lever is raised. This dog is intended to provide additional dogging on large logs when the first cuts are made.

d. Boss Dog. The boss dog (fig 8-15) consists of a series of levers and fulcrums that synchronize the upward and outward thrust of one set of hooks with the downward and outward thrust of another set as the lever is pulled down.

8-9. Networks and Receders

The function of the networks is to advance the log quickly toward the saw line by intervals accurately held to the thickness being cut, and to reverse the knees speedily. Precision in reversing is not vital. The mechanism by which the knees of small mills are advanced may be lever-operated or power-operated. They may be receded by lever, by springs, or by power-actuated devices.

a. Lever-Operated Equipment. To advance the knees in lever-operated equipment, the toothed rim of the set wheel fixed to the set shaft is engaged by pawls attached to the lever (fig 8-16). A pull on the lever is transmitted as a turn on the

set shaft to the pinion wheel fixed to the shaft at each knee. The pinion turns in the rack of the fixed bolster and advances the knee. With single-acting levers, the knees are advanced by forward lever movement only (1, fig 8-16). With the double-acting type (2, fig 8-16) knees are advanced on the back stroke as well, through a second set of

pinions or pawls below the fulcrum of the lever arm.

b. *Spring-Actuated Equipment.* In spring-actuated receders (fig 8-17), a spring coiled about

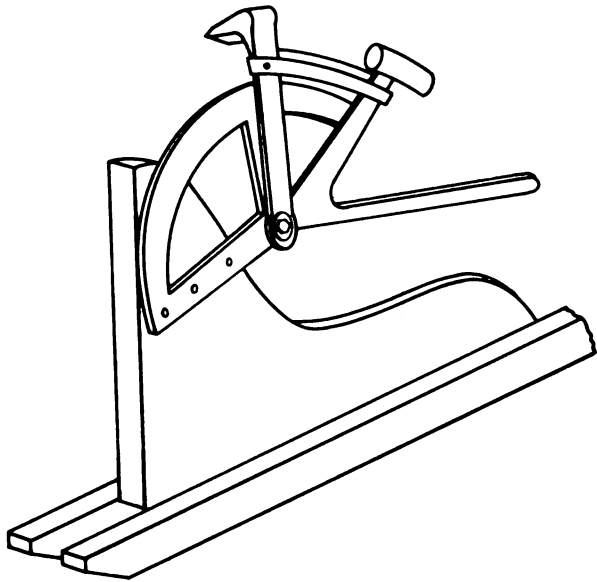

Figure 8-14. Hammer dog.

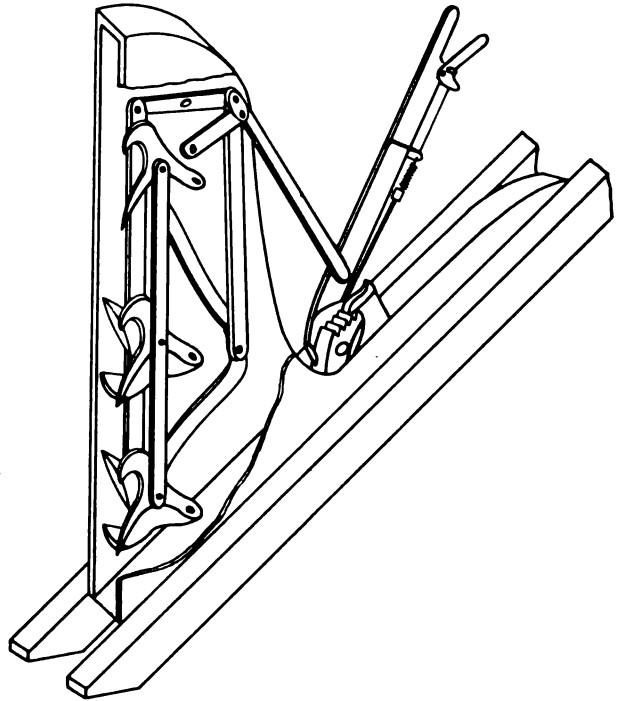

Figure 8-15. Boss dog.

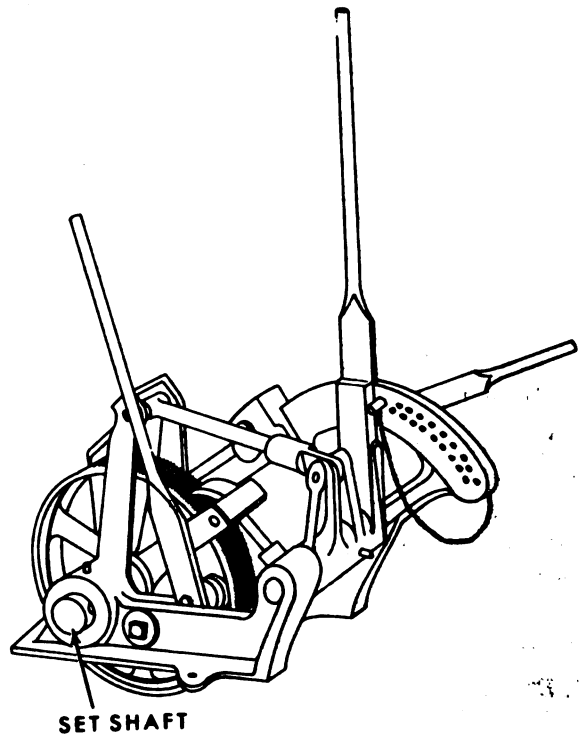
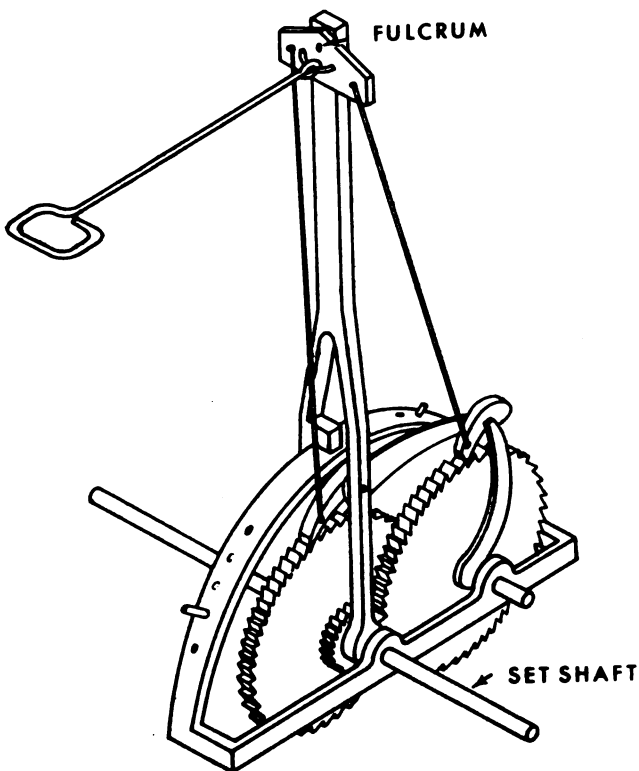

Figure 8-16. Lever-actuated networks.

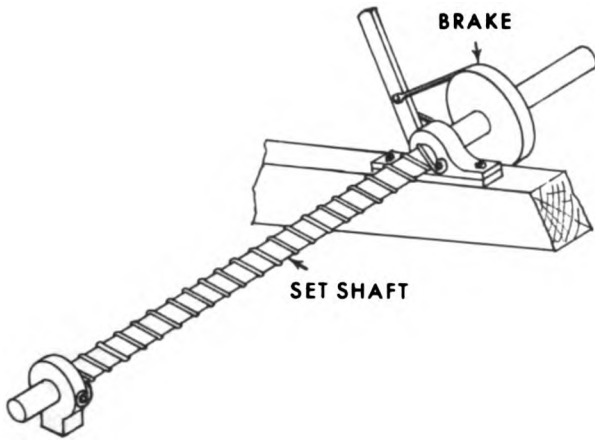

Figure 8-17. Spring-actuated receder.

the set shaft has one end anchored to a collar fixed to the set shaft and the other end anchored to the frame of the setworks. It is so oriented that as the set shaft is turned in advancing the knees, the spring is tightened.

c. Power-Actuated Equipment. Power-actuated receders vary widely in design. Knees may be moved by means of power taken from movable beams, chains, ropes, drums, electric motors, or hydraulic pistons.

(1) *Beams.* A common power source (1, fig 8-18) is an elevated beam alongside the track that rotates a wheel fixed to a shaft having a set of bevel gears connecting with the set shaft. As the carriage is giggered back, the sawyer steps on the foot lever and the knees are receded. Another (2, fig 8-18) takes power from a carriage truck wheel to turn the set shaft.

(2) *Chain.* In the chain type of power setworks and receder, both setting and receding are done by meshing a sawyer-operated foot lever to a power-driven sprocket anchored inside the track. The sprocket engages a chain drive on the carriage that is connected to bevel gears that actuate the set shaft (fig 8-19).

(3) *Rope.* In rope-actuated types, the rope may be stationary or a continuously running belt. The stationary system (fig 8-20) consists of a heavy manila rope extending the full track length about 5 feet above the outside trackway and passing over one and under another grooved pulley of the setworks mechanism anchored on the carriage. When the rope is held taught by the sawyer, as the carriage is advanced or giggered back, the headblocks are advanced or receded. With the continuously running system, the rope, powered by an electric motor, is run over a grooved pulley at

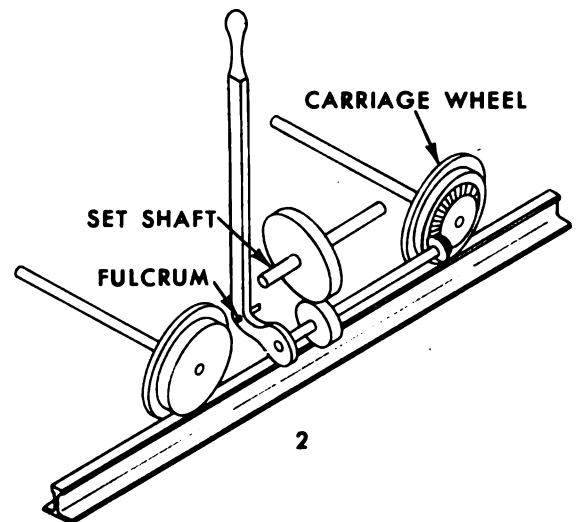
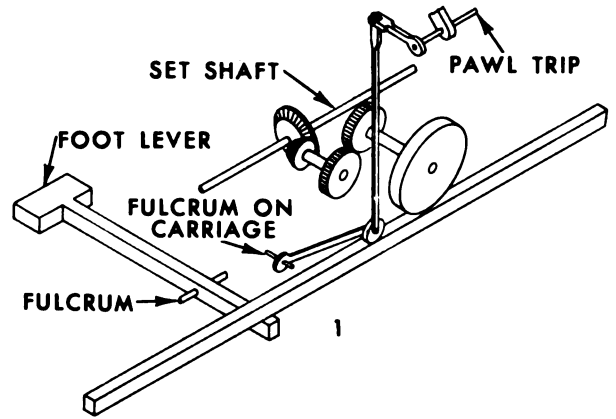

Figure 8-18. Power receders.

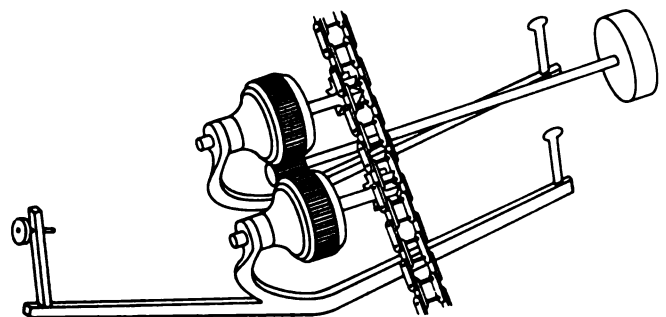

Figure 8-19. Power-actuated setworks.

each end of the carriage track and returned below these pulleys. A friction wheel is placed on the shafts of both pulleys of the mechanism attached to the carriage. The knees are advanced or receded when one or the other friction wheel is brought against the disk by tilting the frame with a lever.

(4) *Drum.* The drum-actuated type (fig 8-21) consists of a constantly revolving cylinder that can be moved laterally by means of a lever

operated by the sawyer. Two friction wheels are fixed to the under side of the carriage so that either may be in contact with the revolving cylinder which engages one friction wheel to advance or the other to recede the knees. The friction

wheels are connected by belts or gears to the set shaft.

(5) *Electric motor.* In the type of setworks and receder actuated by an electric motor, a reversible motor is connected through a gear train to the set shaft. Power is supplied to the motor when the knees are to be advanced or receded.

(6) *Hydraulic.* Hydraulic setworks may be of two types. In one type a hydraulic turbine is connected to the set shaft through a gear train. By operating the turbine in the forward or reverse direction the knees are either advanced or receded. In the other type hydraulic cylinders are connected to the set shaft with a rack and pinion gear train. As pressure is applied to the cylinder the piston is extended and the set shaft is rotated.

8-10. Indicators

All types of setworks have indicators to show the distance between the face of the knee and the saw line. Some, in addition, indicate the number of boards of a given thickness that can be taken by sawing through the cant (1 and 2, fig 8-22). The type having numbers and pointer on the bolster and knees (fig 8-23) is least satisfactory because

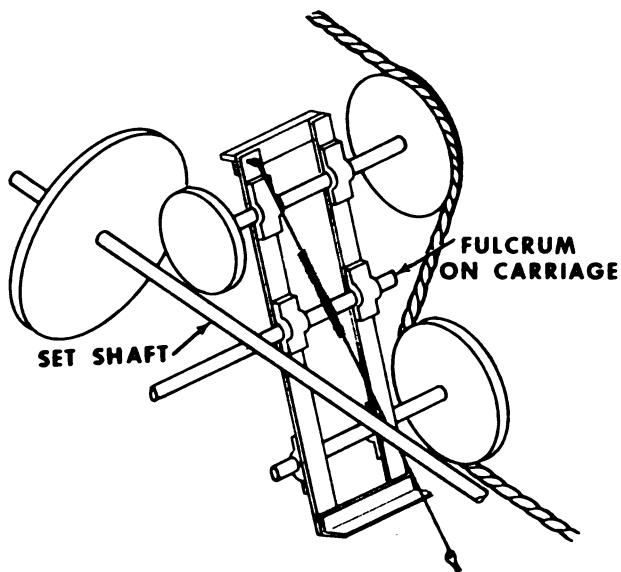

Figure 8-20. Fixed-rope, friction-wheel type of power setworks.

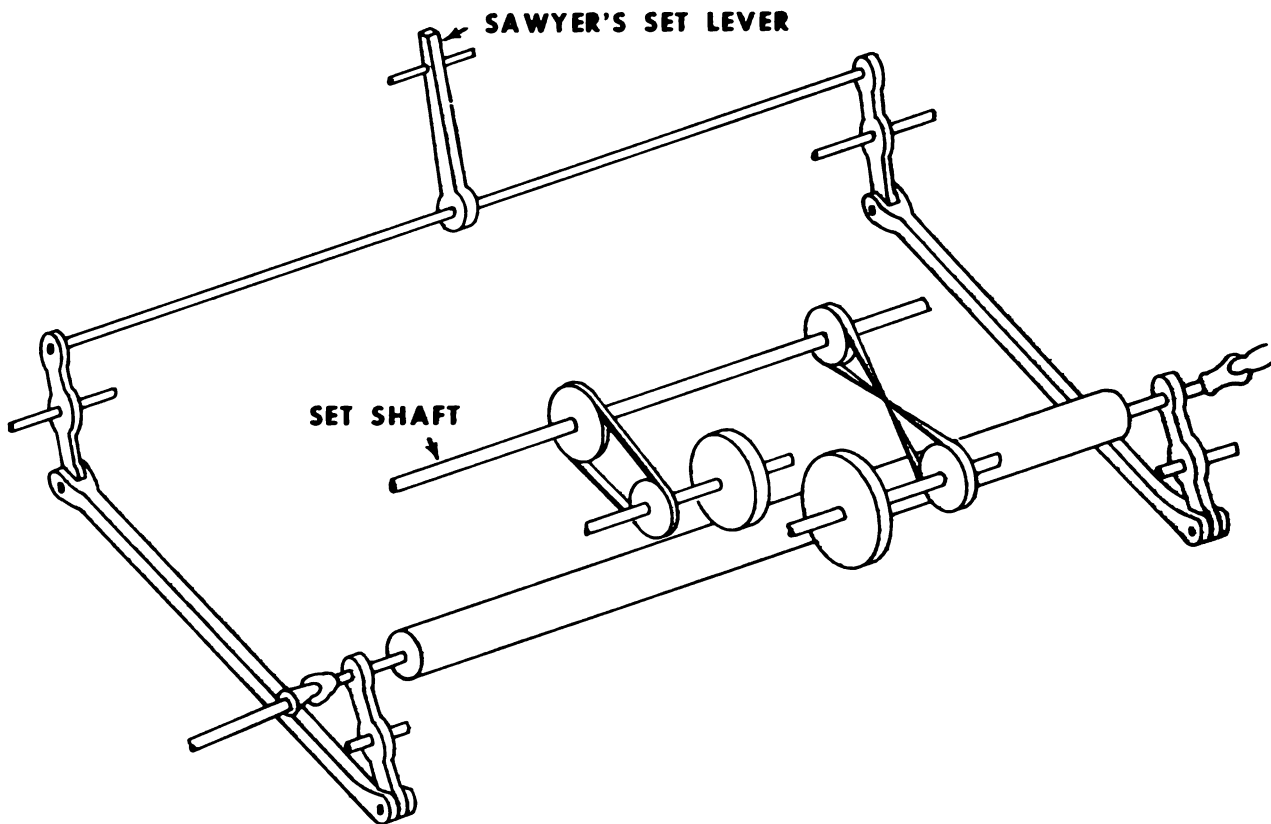

Figure 8-21. Drum-actuated setworks.

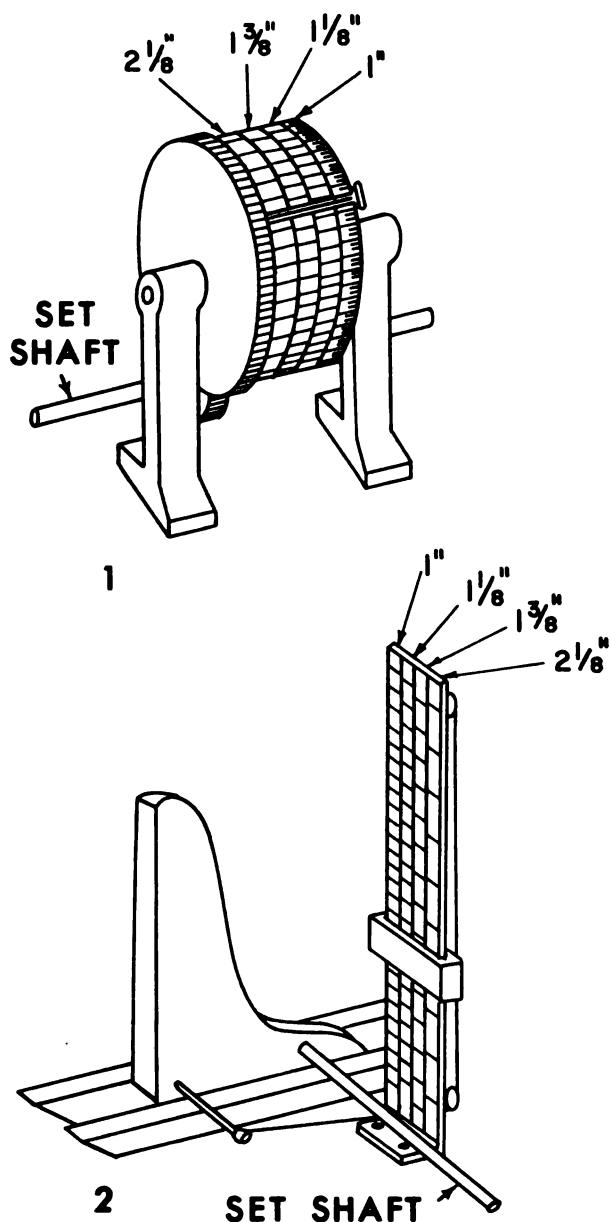

Figure 8-22. Types of indicators.

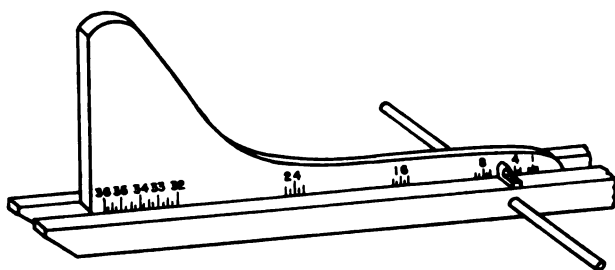

Figure 8-23. Indicator on bolster and knees.

of poor visibility and the difficulty of quickly centering the pointer on the desired mark. A vertical gage board in sawyer-operated networks or a

wheel gage where the sawyer rides the carriage, is easier to read and can guide the sawyer after the final turning to utilize the cant fully.

8-11. Log Turners

Small mills operating in small timber find log turners of little practical value. An experienced deckman with a short-handled cant hook can turn logs under 20 inches in diameter as quickly as can power turners, and with less shock to the carriage. They are rarely used in really portable mills, but are practical in semipermanent sets cutting large logs. Types of log turners used on small mills include the slip-block or the hinged-block; the overhead; the friction; and the rocker-arm type. The slip-block mechanism is useful in medium and large logs because it lessens the shocks to equipment and the physical work of placing the log. It turns the log toward the deck. The overhead type is practical where large logs must be handled because it is durable and faster than cant hooks. The friction and rocker-arm types must be kept in accurate adjustment and be backed up by heavy carriages and trackways; they require a pit or elevated mill and a sturdy carriage.

8-12. Rolls and Spreaders

Standard equipment on most circular mills is a roll or bar attached to the husk ahead of the saw and a spreader and roller immediately back of the saw. The bar steadies the slabbed log (cant) and expedites its passage into the saw. The spreader and roller keep the board from binding the saw and expedite its passage. Usually spreaders are disks that are flat on the log-side face and beveled to a thin edge from the board-side face. Many operators replace this disk with a spreader shaped like a scythe blade and curved to parallel the perimeter of the saw. Knife-type spreaders are required by some State safety codes.

8-13. Edgers

Three types of edgers are used by small mills. The single-saw type usually employs a light flatcar pushed along a trackway to carry the board through the saw one edge at a time. In the type having two or more saws on a single mandrel, the boards are fed through the saws by power rolls and one or both sides are edged or ripped for grade and size requirements. The vertical-edger type with two or more saws on a vertical mandrel is installed ahead of the headsaw to edge the boards as the carriage carries the log through the saw.

a. *Single-Saw Type.* The single-saw carriage edger carries a saw 14 to 16 inches in diameter running approximately 2,000 revolutions per minute on a mandrel about 1-1/2 inches in diameter. The carriage is a platform about 14 feet long and 2 feet wide mounted on trucks, the flanged wheels of which run over a flattopped track.

b. *Multiple-Saw Type.* In the multiple-saw type, all saws may be movable along the mandrel, or one may be fixed and the others movable. The fixed saw is usually attached to the mandrel about 6 inches from one edge of the feed bed. A movable guide on the feed bed can be placed so that any width edge can be taken up to the full 6 inches. The movable saws slide along two keys to opposite sides of the mandrel. Each saw is connected, by means of a fork engaging opposite sides of the collar or guides on the saw, to a lever arm that extends to the front of the machine and is fulcrumed at about its midpoint. An indicator fixed to the lever arm just ahead of either the saws or the feed table guides the operator in spacing the saws. Notches or holes in the frame, together with pawls or pegs on the lever arm, hold the saw in the position required. The board is fed through the saws by means of top and bottom powered feed rolls, one pair just ahead of and another behind the saws.

c. *Vertical Type.* Vertical edgers are mounted on a specially built metal husk frame in such a way that the perimeter of each horizontally mounted saw exactly reaches the log side of the headsaw cutting plane at a line about 2 feet ahead of the headsaw. Thus, as the carriage is advanced the edger saws the edge to the thickness set. The bottom saw may be fixed to the vertical shaft, or all saws may be movable up and down the shaft by means of levers or hydraulic pistons manipulated by the tail Sawyer.

8-14. Trim and Cutoff Saws

Types of trim saws used on small mills are the single cutoff, the two- or three-saw cutoff, and the battery trimmer.

a. *Single Cutoff.* The single cutoff saw (fig 8-24) consists of a swinging frame pivoted to bring the saw across the flow line of the material. The frame normally rests so that the saw is within a guard clear of the flow line. Trimming is done by pulling the saw across the material. The pivot can be above or below the flow line. If its function is mainly to make boiler room fuel, it may be located opposite the tail Sawyer-edgerman,

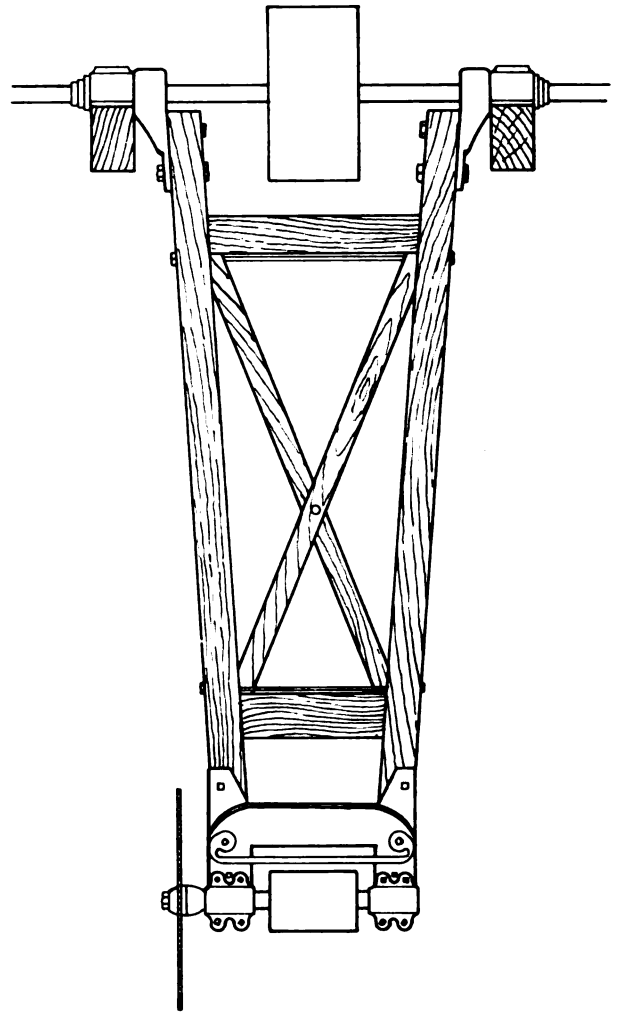

Figure 8-24. Single cutoff trim saw.

who pulls slabs across the edger feed table and segments them with or without assistance. If its function is mainly to cut up slabs for fuel or to trim ties and timber, it is usually located near the back end of the edger in the rolls from the headsaw. If the main function is to trim boards, it is usually near the back end of the edger across from these rolls. The larger sizes take a saw up to 42 inches in diameter, but saw diameters normally are 24 to 30 inches.

b. *Two- or Three-Saw Cutoff.* The standard two-saw trimmer consists of two (or, rarely, three) saws on a single mandrel. The saws are movable along the mandrel, their spacing being controlled with a crank or wheel to permit trimming a variety of lengths. In hand-feed trimmers, the material is placed in front of a movable straightedge guide and pushed through the trim saws. In the power-feed type, moving chains with

lugs carry the boards through the trim saws. In some models the saw-spacing crank or wheel is attached to a movable transfer block; in others it is fixed to the frame. The thickness of the stock trimmed depends upon the saw diameter; 16-inch saws take 3 inches, 20-inch saws 5 inches. Saws run at a rim speed of 9,400 feet per minute, and the feed rate is gaged at 30 or 50 feet per minute.

c. Battery Trimmer. The battery trimmer is the

small-mill adaptation of the multiple-saw trimmer used on larger mills. Four or more saws, each on a separate mandrel and each in a pivoted frame comparable to that of the single cutoff saw, are placed in line across the line of flow material. The operator, through lever action, can extend a selected saw to cut a given length. The remaining saws are retracted either above or below the line of flow of the material.

Section II. MILITARY SAWMILLS

8-15. General

This section briefly describes the two military portable sawmills. The operation of these sawmills is explained in chapter 9.

8-16. Trailer-Mounted Sawmill

The 50-inch trailer-mounted sawmill used by the military is constructed of steel tubing with a main frame assembly welded to form trusses. The carriage is mounted on rollers and is power-driven along rails by rope feed. The sawmill is mounted on a single axle fitted with pneumatic-tired

wheels. It produces 1,000 board feet of softwood cants 1 inch thick and 12 feet long per hour. The sawmill cuts both softwood and hardwood logs. It is powered by a separate diesel or gasoline engine. In an emergency a belt may be put on a wheel (tire) of a jeep to power the sawmill.

8-17. Semitrailer Mounted Sawmill

The military 60-inch semitrailer-mounted sawmill is designed to saw rough lumber from softwood and hardwood logs at a rate of 10,000 to 30,000 board feet of lumbar per day. A diesel engine drives the husk and moves the carriage.

CHAPTER 9

SAWMILL OPERATION

Section I. CREW

9-1. Introduction

This section describes the size of each crew that operates the log yard, the sawmill, and the lumberyard, and outlines the duties of the personnel. The description of duties is that of an ideal operation. Variable local factors may change this plan.

9-2. Crew Members and Duties

a. Portable Sawmill Crew. The crew for a portable sawmill varies, depending upon local conditions. When large, uneven logs are being handled, additional men will be needed on the log skids. With small or medium-sized straight logs, two men can easily handle the log skids. Two to four men are required to take the lumber from the edger and cutoff rig, depending upon the sizes of lumber and the distance to the yard. One man may also be required to perform more than one operation when the number of crewmen is limited. The following is a description of the various jobs performed by a sawmill crew.

(1) The sawyer is usually the sawmill foreman and is responsible for the crew's safety as well as for production.

(2) The block setter works closely with the sawyer. He operates the setwork and also the dogs on the front headblock.

(3) The dogger operates the dog levers on the center and rear headblock knees.

(4) The log-skid man (deckman) keeps a supply of logs ready to be rolled onto the headblock bases. He also holds the log against the headblock knees when the log is being secured to the knees. If logs are heavy or crooked, one or two extra men may be needed on the log skids.

(5) The off-bearer is stationed at the tail of the headsaw to handle boards sawed from the log. In most cases the off-bearer puts the board on the lumber rolls to the edger man. If boards do not require edging, the off-bearer passes the board along the lumber rolls to the cutoff rig.

(6) The edger man operates the edger to remove the bark edges or defective edges from the board.

(7) The edger tailer man removes the board, strip, end, and bark edges from the edger rear table. If a board requires end trimming, the edger tailer man passes the board along the lumber rolls to the cutoff operator at the cutoff rig.

(8) The cutoff operator operates the cutoff rig to square off the uneven ends of the boards.

(9) Two or three lumber stackers are needed to carry the lumber from the edger or cutoff rig to the yard.

(10) The refuse man keeps the cutoff rig and edger free from accumulation of strips, slabs, knots, and ends. He also keeps sawdust from accumulating in the dust holes under the edger and cutoff rig.

(11) The millwright is responsible for keeping belts, accessories, tools, and spare saws in good operating condition. He continually checks the power unit engines and cutoff engine for satisfactory operation. The millwright and his assistant help replace saws and check the installation.

(12) The millwright assistant helps the millwright in the duties outlined in (11) above. The assistant keeps fuel tanks and radiators filled as required.

b. Trailer-Mounted Sawmill Crew. The minimum crew size for the trailer-mounted sawmill is five men: a sawyer, two log deckmen, and two off-bearers. Their duties and responsibilities are the same as those outlined in *a* above.

c. Coordination of Sawmill Crew. For effective sawmill operation, each crew member must understand his duties. He must have enough training to work efficiently with other crew members. It is especially important that the sawyer and block setter work closely together when scaling logs, preparing for cuts, and making cuts. Working as a team, the sawyer and block setter will soon

adopt a few simple operating signals for figuring, turning, and sawing the log.

9-3. Yard Crew

The yard crew responsibilities will depend upon the type of operation taking place. If lumber is

not being stacked and dried but is being shipped as soon as it is sawed, three or four yard workers can keep the lumber moving onto the lumber-hauling trucks. If the lumber must be stacked and stored, then the size of the crew should be increased to handle both stacking and shipping.

Section II. SETTING UP AND OPERATING THE TRAILER-MOUNTED SAWMILL

9-4. Setting Up of Sawmill

a. General. The 50-inch diameter saw trailer-mounted sawmill is usually setup daily. On large setups the trailer is moved ahead progressively to other skidways and away from the lumber, slabs, and sawdust. Ten to twenty thousand board feet is the average cut per setting. An experienced sawmill crew can set up the sawmill in 30 minutes.

b. Setting the Sawmill. Place the trailer-mounted unit within 3 feet of its desired position longitudinally. Dig a hole about 6 inches deep in front of each wheel on level ground so that when the sawmill is leveled up 50 percent of its weight will be removed from the tires. If this is not done, the sawmill will not be rigid enough. Pull the unit ahead to fit the holes. Be careful not to have the holes so deep that the sawdust conveyor rests on the ground when the unit is in the holes. Unhitch the towing vehicle from the sawmill. Place the power unit near the sawmill. At this time check that no difficulties will prevent proper alinement of the drive belt from the power unit to the sawmill husk.

c. Leveling. Proceed with leveling the sawmill and removing its weight from the wheels. Place the two center legs down first and level the sawmill crosswise at this point. Next, place the two legs on the log end into position (down) and level. Then lower the two legs on the lumber end and allow just enough tension to give adequate support. Slide the carriage forward so the crank can be used to adjust the legs. The frame must be relatively level before the carriage can be released to move it for the final adjustment of the legs. Be sure that some support, such as a plank of timber, is placed on the ground underneath each leg to prevent it from settling into the soil as operations proceed.

d. Bracing. Secure a brace from the frame of the sawmill to the ground or power unit in order to compensate for drive belt tension. If this brace is put between the sawmill and the power unit,

there should be some means, such as a jack, for increasing its length in order to have proper belt tension. Where longer drive belts are used and the brace extends from the sawmill to a stake driven in the ground, the tightening adjustment should be placed between the power unit and the stake.

e. Sawdust Conveyor. Set up the sawdust chain and anchor it. Use a steel bar 3 or 4 feet long and about 1-1/2 inches in diameter. Sharpen one end of the steel bar and drive the bar into the ground at a slight angle so the top leans away from the sawdust conveyor assembly and towards the center of the sawmill. This will prevent the vibration from loosening the anchor.

f. Reeving Feed Rope.

(1) First secure one end of the rope by passing the end through the loop at the bottom of the feed lever (which is the free lever in the center of the carriage). Hook the end of the rope securely on one of the hooks provided on the side of the lever for convenience in tightening the rope.

(2) Next, pass the free end of the feed rope toward the log end of the frame under the carriage above the cross shafts. Pass it down through the pulley on the extreme log end and back toward the center through the idler loop and over the top of the large feed drum. Then make two complete coils around the feed drum from the side of the drum toward the saw. This will bring it in alinement with the pulley near where the frame hinges. Pass the ropes up through this pulley and back toward the log end of the frame again. Be sure that the feed rope is above the cross shafts and under the carriage to the extreme log end of the carriage. Then, pass it up through the loop provided and secure it through the hook bolt in the pipe winch. By tightening this winch, the rope can be adjusted to the proper tension.

g. Reeving Reverse Rope.

(1) To reeve the reverse rope, proceed as with the feed rope, except that it is reeved in the opposite direction with only two coils around the drum. The reverse rope is fed onto the drum from

the bottom whereas the feed rope is fed onto the drum from the top.

(2) When both feed rope and reverse rope are threaded, tighten the winch on each end of the carriage until the feed lever is in a vertical position. Leave enough slack for at least 1 foot of movement (not over 2-1/2 feet) when a reasonable pressure is applied. If ropes are left in overnight, be sure to slacken them at each end.

(3) The feed rope is usually 64 feet long and the reverse rope 56 feet. In this way, the feed rope, after it is worn in the middle, can be spliced and used as a reverse rope, thereby obtaining maximum use from a set of ropes. One set of ropes should last through 40 thousand board feet (Mfbm) of sawing or one week's sawing, after the drums are worn smooth.

(4) After threading the ropes into the sawmill and checking the tension, be sure that the neutral position lock on the feed lever and the handbrake are set before operating the power unit and sawmill. Be sure that the lock pin which prevents the carriage from traveling is in a locked position; remove it only after the sawyer is in position on the carriage. Test the slack in the feed lever look for a slight forward or backward movement of the carriage as the set lever is moved. With a little experience it is not difficult to determine the proper tension to have on the ropes before releasing the lock pin.

h. Operation Test. Make several short travels of the carriage. Increase the length of travel until several full length travels are made before attempting to take on the first log. This should be practiced after every shutdown of the lumber sawmill to make sure that the carriage is in the clear and that the ropes are properly threaded and tensioned.

9-5. Operation of Trailer-Mounted Sawmill

a. Controls. The controls for operating the trailer-mounted sawmill are located on the sawmill carriage. They consist of the feed lever, the set lever, and the trip release lever. The operator rides the carriage and stands facing the headsaw with all operating controls located to his rear. The three dogs are also operated by the sawyer. The dogs are of the ball, lever type, adjustable to different size logs up to 30 inches in diameter. There are five headblocks on the carriage.

b. Log Sizes. Although the trailer-mounted unit will saw logs up to 30 inches in diameter, the maximum desirable log diameter is 26 inches.

Heavy logs longer than 20 feet tend to tip up the opposite end of the entire sawmill frame.

c. Maintenance.

(1) All working parts must be lubricated in accordance with the lubrication order on the equipment.

(2) During operation, check the saw for overheating due to dullness, misalignment, pitch deposits, and chips collecting on the headsaw apron.

(3) Before starting the saw, check the natural lead and arbor alignment of the saw with the carriage.

(4) Check saw guides for correct setting.

(5) Check that saw mandrel is running evenly and bearings are not overheating.

(6) Make sure that the entire unit is level crosswise and lengthwise.

(7) Make sure that the sawdust auger and chain are free of sticky material.

(8) Make sure that the feed and reverse ropes are dry before operating the sawmill. Check the condition of the ropes before starting the operation; replace worn or frayed rope. Keep sawdust clear of the ropes underneath the carriage because pitch and moisture from sawdust on the ropes will cause them to run unevenly. This is especially true when sawing frozen timber.

d. Starting and Stopping.

(1) *Starting.* The husk of the trailer-mounted sawmill is not provided with a clutch. If the power unit is in gear then the headsaw will be running and the carriage will operate. Before starting the headsaw, make sure that all personnel are clear of the drive belt and the headsaw. See that feed set and trip release levers are in their neutral position. Before placing a log on the carriage, test its operation by moving it along the full length of trackway several times; see that the saw is running true.

(2) *Stopping.* Set all levers in their neutral position and then stop the engine or set the engine clutch in its neutral position. If the unit is to be shut down for an extended period, slacken the drive belt, the feed rope, and the reverse rope. Protect all mechanical parts of the sawmill from the weather. Make sure that ropes and belts are not exposed to rain or snow.

9-6. Operation of Semitrailer-Mounted Sawmill

The 60-inch semitrailer-mounted sawmill (para 8-17) is operated in approximately the same way

as the trailer-mounted sawmill. The larger saw (60-inch) will saw somewhat larger diameter timber.

9-7. Movement of Sawmill to New Location

a. Dig sawdust out from under the sawdust auger before retracting the legs, to eliminate the possibility of bending the screw conveyor on the sawdust mechanism.

b. Disconnect the power unit drive belt from the husk. Place the drive belt with the sawmill.

c. Take out the removable section of the guide rail before attempting to fold up the folding end of the frame.

d. Remove the sawdust and soil from in front of the wheels to facilitate forward movement of the trailer.

e. Inspect the entire unit for worn, damaged, or missing parts. Repair or replace all parts necessary.

f. Be sure that the carriage is securely locked before attempting to move the trailer over the road.

g. Be sure that headblocks are well advanced to a position which will eliminate projection of the gear racks and provide clearance for road travel.

h. Check that all tools and equipment necessary for operation of the sawmill are with the unit and in good condition.

Section III. SAWING PROCEDURES

9-8. Basic Factors

a. The most advantageous method of sawing logs on any operation depends upon the demand for different grades and the thickness desired within a grade. Thick stock of the better grades is normally more desirable than inch lumber. In hardwoods (graded from the poor face) the likelihood that the grade on the inside face will hold up to that on the outside decreases as thickness increases; hence, to capitalize on thick stock requires expert knowledge by the sawyer.

b. The sawyer must know the following details of lumber grading:

(1) The minimum width and length provisions of each grade, as a guide when slabbing.

(2) The defect allowance of a clear-face requirement of the grade as a guide in log turning.

(3) The grade provisions applying to the lowest desirable grade, in order to avoid wasting time or making undesirable stock.

c. The edger operator must know—

(1) The minimum width-length provisions of each grade.

(2) The amount of permissible wane.

(3) The provisions covering standards of manufacture, particularly that applying to crook.

d. Both the sawyer and the edger operator should take into consideration the minimum thickness, width, and length provisions of the grade rules that apply to dry lumber. They also must allow for shrinkage in thickness and width in cutting green lumber. Hardwoods are edged to give

the widest possible board in any fraction of inches above the minimum required. Softwoods are sized to give widths in 1- or 2-inch intervals.

e. Recommendations applicable to milling both softwood and hardwood logs are:

(1) Clear faces should be taper sawed in order to get the maximum possible footage in upper grades.

(2) Thin stock should be taken next to the slab to minimize edging waste.

(3) The pith should be inclosed within a boxed heart item where splits and checks are not considered a degrading characteristic.

9-9. Milling Softwood Logs

a. To minimize waste, boards of different sizes should be made, the particular sizes being varied according to the log. In this way complete utilization is most nearly attained. It is also desirable to saw the log in such a way as to produce lumber of maximum grade values.

b. The size and grade standards for desirable items are given in grading rules and a sawyer should master these provisions for the species sawed. Normally, however, there is a greater demand for certain sizes or grades than for others. For instance, the nominal widths specified under softwood rules include each inch class from 3 to 12 inches, but a need rarely exists for widths of 7, 9, and 11 inches. Likewise, for some softwood species, No. 1 common boards are in little demand, whereas No. 1 common dimension is readily uti-

lized. Since softwood is graded from the best face, usually the sawyer can estimate the approximate grade before setting is done and readily substitute dimension for boards.

c. The several methods of sawing softwood logs differ mainly in the sequence used in turning. The two objectives of a sawyer are to recover maximum grade values and get maximum volume production per hour. It is not possible to get both by any one method. Either the frequent turning required to recover the maximum grade values reduces volume, or the minimum turning necessary to get maximum production sacrifices grade. In order to get a balance between grade values and production volume, turning procedure must be varied in accordance with log qualities, sizes, and mill facilities. No rigid set of instructions can be universally applied. The ones suggested herein are commonly used and provide the beginner with a definite starting point.

d. The turning sequence (1, fig 9-1) is easily identified by referring to the first log face to be sawed as face 1, after which faces 2, 3, and 4 will be turned in sequence, starting from the top and ending with the bottom. Face 3 is opposite face 1. Greater production volumes are possible by using the 1-3 sequence; better grades usually result from some combination of 1-2-3-4. This is true because the best grade of lumber in a log is just under the slab, while the heartwood contains the poorest grade. In the faster 1-3 sequence there will be some heartwood in the majority of boards, while in the slower 1-2-3-4 sequence heartwood will appear only in the last few.

e. In sawing logs, the sequence in which faces can be sawed is limited by the requirement that adjoining sawed faces must be at right angles. To insure this, the first face sawed must be turned to the bolsters or to the knees. On mills equipped with dogs incapable of preventing the log from turning while face 1 is sawed, a slab is taken from face 4 and the log turned so that face 4 rests on the bolsters. In the following instructions it is assumed that the dogs will hold the log firmly; otherwise, the outlined procedure must be changed so that face 3 is slabbed and turned to the bolsters before face 1 is worked.

f. For logs 12 inches or less in diameter and promising only common grades, the 1-3 sequence is used, sawing nearly to the center from face 1 and then turning the log 180° and finishing it. The dog board (the final board) is usually cut to dimension size. If the first face is not worked to

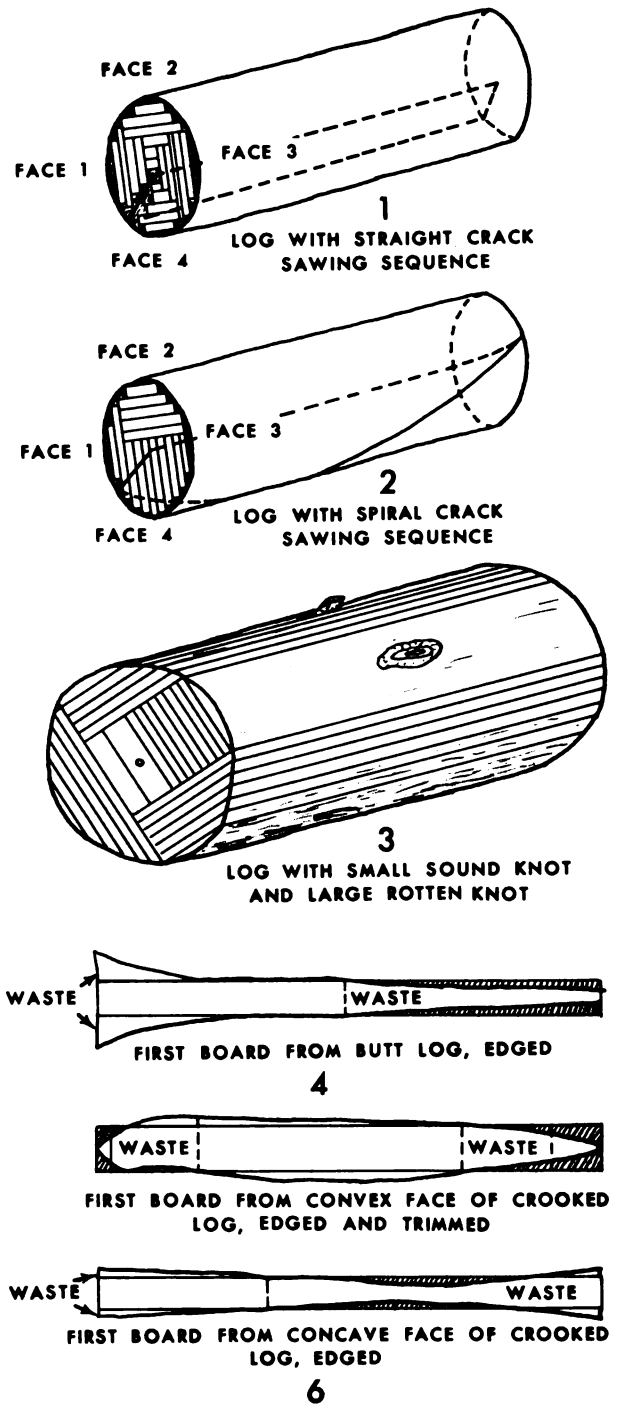

Figure 9-1. Sawing procedures.

near the center of the log, most types of dogs will fail to hold the piece as the opposite face is worked beyond the center.

g. The first slab should give a face of a minimum desirable width. In slabbing the opposite face, the sawyer adds to the thickness and saw kerfs remaining to be cut and so slabs the piece as to end up with a dog board of proper size. In

practice the second face to be cut is brought to the saw line to give a tentative face of minimum width, and the sawyer then decides whether a thicker slab is required in order to have a dog board of proper size at the finish.

h. For logs of common grade quality exceeding 12 inches in diameter, the 1-3 sequence has disadvantages. The edger operator is prone to lose potential footage in the wide center boards through improper ripping. Lumber from rip lines along or near the pith tends to crook in drying. For such logs, a 1-2-3 sequence is recommended if turning is done with cant hooks, or a 1-2-3-4 sequence if powered equipment that turns the log up and over is used. In using the 1-2-3 sequence, faces 1 and 2 are slabbed to give boards of minimum width, and face 3 to end with a dog board of proper size. In the 1-2-3-4 sequence, face 1 is slabbed to give boards of minimum width, face 3 to end with a cant thickness of 6, 8, 10, or 12 inches instead of a dog board, face 2 to give a face of minimum width, and face 4 to give a dog board of proper size as sawing is completed.

i. A secondary refinement in sawing of common grades is that knots should be toward the center and away from the edges of sawed stock. Thus, so far as possible, the log should be placed on the carriage so that the visible knots will be toward the center of the face rather than at the margin.

j. The recommended practice for logs promising a portion of their lumber in grades above common is to place the high-grade faces to the saw and taper-saw them (parallel to the bark). If all but one of the faces is clear, the log is placed with the poor face to the saw, slabbed, and turned to face 2 on mills employing turndown equipment. Before face 2 is sawed, the small end of the log is set out to get a slabbed face of uniform width and length of the log. After slabbing to a face of minimum width, this face is sawed until the grade drops to common.

k. The log is next turned to bring face 3 to the saw, which is slabbed and sawed as was face 2. By slabbing face 1 as instructed, face 3 will be taper-sawed without setting out the small end. Next, the log is turned to face 4, the small end set out as for face 2, and this face is sawed until common lumber develops. Before turning to another face the taper is taken out by retracting the taper blocks, bringing the cant (a log that has been slabbed on one or more sides) against the knees, and sawing the wedge so as to have a cant thickness of 6, 8, 10, or 12 inches. If short pieces are useable, one or

more short boards are taken in straightening the cant. In order to end up with a dog board of proper size, the sawyer adds the thickness and saw kerfs remaining to be cut and slabs accordingly on the third and fourth faces of the log.

l. If two adjoining faces are clear, the log is placed so that one poor face is to the saw and the other is up. Face 1 is slabbed and may be sawed lightly, then face 2 is brought to the saw and treated likewise. Faces 3 and 4 are successively taper-sawed deeply without use of taper blocks.

m. If two opposite faces are clear, the log is placed with a clear face on top. After face 1 is worked as described above, face 2 is brought to the saw, the small end of the log is set out, and this face is worked until common lumber develops. Next, face 3 is sawed as described for face 1. Face 4 is taper-sawed after the small end is set out, and before the cant is turned to another face it is straightened as previously described.

n. A log with a single clear face is placed on the carriage with this face against the knees, thus permitting the clear face to be taper-sawed without the use of taper blocks. These instructions are for mills employing equipment which turns down logs. For mills turning up, the log is turned either 180° or 270° after face 1 is worked and the procedure modified to conform to this different turning system. Small mills having no demand for upper grades saw around large logs as described, except that the small end is not set out.

o. Rough softwood lumber that is to be surfaced, or surfaced and patterned, must be edged and trimmed to widths and lengths that allow for the manufacture of finished lumber of definite size standards. Usually nominal widths are 3, 4, 5, 6, 8, 10, and 12 inches with even-foot lengths. A flitch that can be edged and trimmed to produce a board of 9-inch nominal width and 11-foot length, but cannot be made 10 inches wide by 12 feet long, should normally be sized to 8-inch nominal width and 10-foot length. Since wane is excluded from surfaced or patterned material for most items, edging and trimming should remove wane that will not be surfaced out.

p. A simple rule to guide the edger operator is that normally material should be edged to get the widest stock possible and in the maximum even-foot length, but that the width should be reduced by 2 inches wherever 4 feet or more can be gained in length. The edger operator thus tentatively estimates the even-foot length for a board of a given

maximum width and decides if a width reduction of 2 inches allows for a length extension of 4 or more feet.

q. The edger operator should have definite instructions on the green width required for each width class manufactured in the mill. Basically these widths depend upon an allowance for shrinkage in drying, usually 1/16 inch per inch of width, and an allowance for planing, usually 1/16 inch per face planed. These allowances are added to the actual width standards set up for yard items by military specifications.

r. Wide pieces should be ripped into any series of widths that will raise the grade of one board above that of the wide piece. If no grade rise is possible, the piece should be ripped to produce a board 12 inches wide and the others as wide as possible, but normally avoiding 7-, 9-, and 11-inch widths. Where possible, wide pieces should be ripped so as not to intersect a knot that may fall out during seasoning, nor should material be ripped so that the pith is at the edge.

s. The trimmer operator trims to produce a desirable board of the maximum even-foot length possible. Usually a 2-inch allowance in excess of the even-foot length is made when trimming.

9-10. Milling Hardwood Logs

a. Sawed hardwood is mainly channeled to two outlets—sources using material of random width and length, or construction units which require material of specified size.

b. The sawing practice for grade-sawing random size hardwood lumber should be to work the high grade material from the better faces by taper sawing, then turn to a different face as the grade drops below that promised by adjoining faces. This process of working around the log is usually profitable if it results in raising the grade from No. 1 common to No. 2 common.

c. As the log is transferred to the carriage, the sawyer should decide how to divide it into four cutting faces and the probable sequence to be followed in sawing them. Deciding on one face automatically fixes the other three. A mirror at the deck end of the track enables the sawyer to see end defects of logs. It reflects a view of the end of the log that is farthest from the sawyer when the log is against the knees of the carriage. This helps the sawyer in determining faces and the sawing sequence. In the following description, face 1 is to

the saw, face 2 on top, face 3 against the knees, and face 4 on the bolster for initial sawing as shown in figure 9-1.

d. For clear, straight, sound logs with the pith as the approximate center it makes no difference how the log is divided into faces, and the cutting sequence from one face to the next is that involving the least delay. Thus, at mills turning down, the cant is turned down 90°. At mills turning up, the cant is turned at least 180° from the first face. If the pith is offcenter, the log should be placed so that one face is perpendicular to the longest radius.

e. Logs with a straight crack are placed so that the crack is at the board edge that is to be taken out in edging (1, fig 9-1). The log is placed so that the crack coincides with the radius that is 45° to the bolster and toward the saw. If, however, face 2 promises high-quality material and hence should be taper-sawed, a slab is taken from face 4 before turning to face 1. This high-quality face 2 is taper-sawed as described so that a board of minimum useful width can be taken the full length of the log. At right-hand mills turning down, the cutting sequence usually is face 1, 2, 3, and 4. At right-hand mills turning up, the sequence is usually face 1, 3, 4, and 2.

f. Logs with spiral cracks (2, fig 9-1) are placed so that one end of the crack is in the same position as logs with straight cracks. The damaged zone is downward and back toward the knees. At mills turning down, the first face is usually sawed until the crack appears on a board edge, after which the other faces are successively worked; but where spiral cracks extend for 1/3 or more of the circumference, the unaffected faces are sawed deeply before short pieces are cut from affected faces. At mills turning down, face 1 is worked lightly, face 2 deeply, and the cant finished on face 3. At mills turning up, face 1 is worked lightly, face 3 is slabbed, and face 2 is worked deeply, face 1 is worked nearly to the pith, and then face 3 is finished.

g. Shake, rot, or spider heart (several splits radiating from the pith) that is restricted to the center does not influence the manner of dividing the log into faces or sawing sequence. The undesirable core is boxed and discarded. Logs with shake or rot in the outer zone are placed on the carriage in such a way that a cutting face is parallel to the straight line, thus connecting the ends of the arc of shake or the long axis of the rot area. The face affected is sawed last.

h. Logs with wormholes should be placed on the carriage so that faces visibly free from holes are sawed before the log is turned to the affected areas.

i. Downgrading defects listed up to this point usually are detected from the ends of the log. Defects detected by surface inspection, such as bud clusters, bird pecks, bulges, bumps, burls, butt scars, cankers, conks, holes, knots, overgrowth, and wounds, can be treated as a group so far as they influence the manner of dividing the logs into faces and the sawing sequence. Defective logs include the full range between those with few indicators (defects) affecting a localized area and those with many indicators spread over the entire surface. Surfaces free of indicators are determined as the basis for initially placing the log, and it is then successively turned so as to cut the high-grade material from these faces before deep cuts are made into the defective ones. Thus, for a log with three high-grade faces, the defective one should be slabbed and turned down 90° or up 180°, depending on mill practice. The defective face is sawed last.

j. A log having a single high-grade face is placed with this face against the knees. At mills turning down, a 90° turn is used for successive faces. At mills turning up, the turning sequence after the first face sawed is 180°, 90° and 180°.

k. Where a clear face adjoins one having one or more defects that seem likely to be removed in edging, the log is placed so that these defects will be near the edge of the defective face. Cankers, conks, holes, and large dead knots, however, are indicative of extensive defects not likely to be removed by edging, and the sawyer should center them on the poor face (3, fig 9-1).

l. Logs with sweep should be placed on the carriage with the sweep facing out. The four faces should be successively worked in the sequence dictated by the turning equipment. Better-grade recovery usually results when the widest boards are cut from the faces that are at the top and bottom with reference to the first face sawed.

m. It is important that the location of the faces be in accordance with the factors outlined. The high-grade faces are usually sawed parallel to the bark and the low-grade ones in the most convenient way to speed up the work. If a high-grade face is opposite a low-grade one, the good one should be sawed parallel to the bark. This can be done either by placing the poor one against the

knees and setting out the small end of the log, or simply by placing the good face against the knees and slabbing the poor face first.

n. If the high-grade faces are opposite each other and the log is characteristically free of defects nearly to the pith (as with red oak, ash, and yellow poplar), one good face is placed against the knees and the other is partially sawed without regard to parallelism. In this manner each good face is taper-sawed and log length boards of high-grade will be obtained. If the log is characterized by interior defects that extend beyond the pith zone (as with sugar maple and birch), the small end is set out enough to permit cutting a slab of uniform width the full length of the log. When the opposite good face is turned to the saw, this process is repeated. After this face is cut and before the log is turned to another, the cut is "straightened" by retracting the taper levels, setting the small end back against the knees, and sawing the face to produce a cant with opposite faces parallel. The purpose of this is to take out the taper from the low-grade material in the core instead of from high-grade material in the outer zone.

o. When slabbing parallel to the bark, the face of the slab should be the minimum width required—6-1/2 inches for grades above No. 1 common and 3-1/2 inches for No. 1 common or lower. With any face, a 4/4 cut is usually taken next to the slab in order to minimize edging waste, but if the face is opposite a previously sawed one, the sawyer slabs so that the final piece will conform to the size requirements, thicknesses, or widths of the intended item. Faces of high-grade material are sawed deeply and those of low grade are sawed lightly. The usual practice is to continue sawing a face until the grade drops to that of the adjoining faces. This progressive turning continues either until the central portion is sized to meet construction item specifications or until the grade of lumber becomes substandard. For small mills that specialize in cutting factory lumber, such turning is justified as long as lumber better than No. 3 common can be cut.

9-11. Procedure for Edging

a. Normally, material for random size use is edged to get the maximum width possible in inches and fractions thereof. For construction items, it is edged to conform to definite width specifications.

b. The minimum width for dry random size lumber is 6 inches for firsts and seconds and 3

inches for common. Normally, a shrinkage allowance of 1/16 inch per inch of width is made, so that green firsts and seconds should be at least 6-3/8 inches and green common at least 3-3/16 inches in width. Boards are usually edged with the narrower (bark) face up.

c. Boards below firsts and seconds are edged so that the surface area of the wane or rot left on the board is approximately equal to the area of sawed, sound face of the edging (4, 5, and 6, fig 9-1). For firsts and seconds, wane and rot cannot exceed 1/12 the surface measure nor aggregate more than 1/12 the length of the piece. Shakes and splits in first and seconds cannot total in inches more than twice the surface measure of the piece in feet, nor diverge from the parallel more than 1 inch per foot of length unless they total 1 foot or less in length. They should be removed by ripping or trimming if they violate this requirement in firsts and seconds or extend more than 1/3 the length of the piece in common grade.

d. All pieces more than 16 inches wide should be ripped if the grade of the resulting two boards does not fall below that of the wide piece.

e. Boards are ripped to raise the grade when 1/2 or more of the original surface measure is raised at least one grade.

f. Material for specific construction jobs is edged to conform to definite width requirements. Items may be made from a limited number of species and sized to a restricted series of widths, thicknesses, and lengths as for car stock (flooring for box cars) and construction boards. The sawyer edger operator and trimmer must know the size, species, and allowable-defect provisions of grading rules for such items. The 1/16-inch allowance per inch of width should be made to take care of shrinkage from the green to the dry condition. Material more than 3 inches thick is normally edged on the headsaw. A high percentage of all construction items is produced by the headsaw from squared cants and requires no edging. The small amount requiring it is edged according to the size and quality specifications for the particular product. These products are usually so varied that general edging instructions cannot be given.

9-12. Procedure for Trimming

a. Each piece should be trimmed 2 inches over the nominal foot, and boards below firsts and seconds should be trimmed so that the surface area of the wane or rot left on the board is approxi-

mately equal to the area of the sawed sound face of the trim (4, fig 9-1). For firsts and seconds, wane or rot in excess of 1/4 of the affected area within 1 foot of the end must be trimmed. At least 1/2 the area of this last foot must have a clear face. The rule for edging boards with splits in firsts and seconds also applies to trimming them. They are trimmed so that splits total no more in length in inches than twice the surface measure in feet, nor diverge more than 1 inch to the foot in length, except when the board is 1 foot or shorter.

b. For specific construction jobs, each item is trimmed to conform to specific length requirements and with wane, shake, or crack provisions for the item as listed in the applicable grading rules.

9-13. Sawing Oversized Logs

a. There is no efficient saw-around technique of cutting logs that are too large for the headsaw. The relation between saw diameter and maximum log diameter is given in paragraph 10-3a.

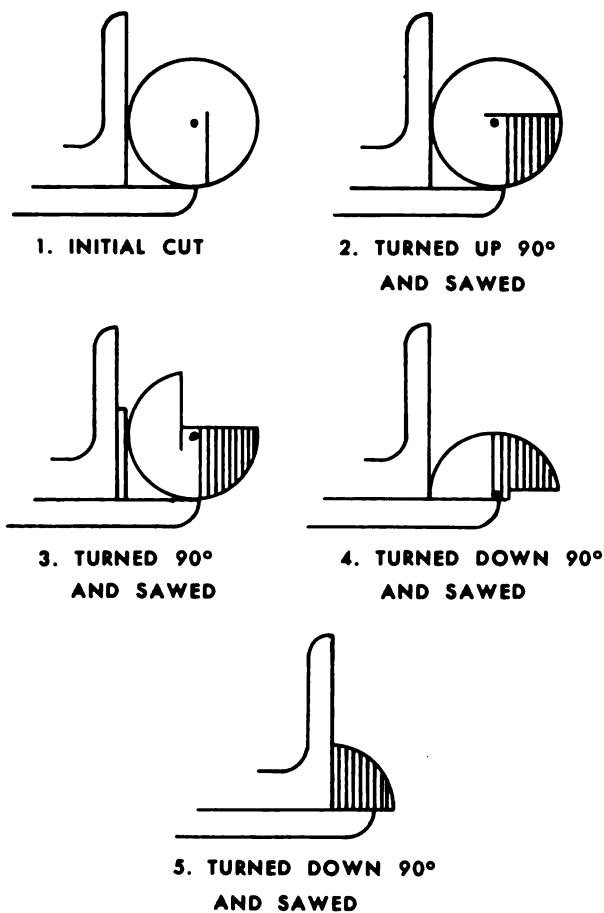

Figure 9-2. Sawing oversized logs.

b. Logs having diameters slightly larger than those tabulated may be sawed by using approximately a 1/8 turn instead of the 1/4 turn which is common with the turning-around method, after as much is taken as can be sawed from one face. Ultimately the many-sided piece thus formed can be squared and sawed as in the normal procedure. This method is wasteful of material and time.

c. Logs with diameters nearly twice the height of the portion of the saw above the bolsters can be reduced in the manner outlined in (1) and (2) below.

(1) Set the log to the saw so that the saw line will be a distance from the face of the knee equal to the height of the saw above the bolsters, and cut a line (1, fig 9-2).

(2) Dogs must be fixed to hold the log firmly; feed must be slow. The log is turned up exactly 90° and the stock items sawed. Sawing is discontinued before reaching the log pith or center (2, fig 9-2). Series of cuts should extend exactly to the first saw line. The log is again turned up 90° and the small end is set out so that the ensuing saw lines will follow planes parallel to the first saw line taken. The sawing of the stock items is discontinued before reaching the center (3, fig 9-2) The log is turned down 90° and stock items are sawed to beyond the center (4, fig 9-2) then the log is turned down 90° and finished (5, fig 9-2).

Caution: This procedure is extremely difficult and should not be attempted by any but thoroughly experienced sawyers. Otherwise, considerable damage can be done to the saw and sawmill equipment.

d. Powered drag saws and chain saws are sometimes used to reduce oversized logs to segments that can be cut on the head rig.

9-14. Size Standards

a. Lumber, timbers, and ties must meet the precise size standards given in military specifications. Sawing inaccuracies are the cause of failure in producing standard size timber and ties. Shrinkage (green-to-dry) and sawing inaccuracies are the causes of failure in producing standard size lumber and light framing material.

b. The causes of inaccurately cut lumber are—

(1) Faulty condition of the saw. This may be due to teeth being out of line with the perimeter, holders or teeth out of line with the saw plane,

excessive or uneven swage, teeth that are dull on one side, or incorrect tension.

(2) Worn bearings on the mandrel, the carriage wheels, or the setwork.

(3) Poor installation of the carriage and saw.

(4) Lodging of chips between the log and headblock or on the tracks.

(5) Careless setting or miscalculation.

(6) Inaccurate manipulation of the dogs, or use of types of dogs mechanically unfit to hold the log firmly.

(7) Frozen timber or unequal stresses in the wood.

9-15. Common Causes of Faulty Sizing

a. *Dog Board Thicker or Thinner at Top Than at Bottom Edge.*

(1) Faulty alinement of the saw and headblocks will cause unequal thickness of the dog board. The knee face should be at right angles to the top of the bolster, and the saw plane should be parallel to the knee face. The specific cause of this type of inaccurate sizing can be in the track, carriage, or saw mandrel.

(2) The cause of the misalignment can be checked by stopping the carriage so that the headblock is opposite the saw, placing one leg of a carpenter's square along the face of the knee and then flat against the saw. If either the saw or the knee face fails to show a right-angle relationship to the bolster top, the adjustment is faulty. Each headblock should be checked and corrected by leveling the track. Where faulty alinement is due to worn headblocks, the headblocks must be replaced. Bolsters should be firmly anchored to the carriage bed.

b. *Dog Board Thicker at One End Than Other, or Variations in Thickness Between Ends.*

(1) Variations in thickness along the length of the dog board may be due to a twist or dip in the track, to sideplay between carriage frame and wheels, to misalignment of knees, or to end play in the saw mandrel. Track alinement can be the saw mandrel. Track alinement can be checked by stretching a fine brass wire just clear of the top of the guide rail from the deck to a distance of a carriage length beyond the saw. Sideplay can be detected by giving the carriage frame a vigorous sideward shove.

(2) The check of knee alinement consists of setting the faces of the knee so that they are about 2 inches from the front of the bolsters. To

do this, the carriage is stopped so that the front knee is opposite the saw. The exact distance from the saw blade to knee face is then measured. The place on the saw where measurement is taken is marked. The rack of the knee should be tight against the pinion of the set shaft. Then, the carriage is moved to bring the next headblock opposite the mark on the saw and measurement is taken as it was for the first block. This procedure is repeated for all headblocks. All readings should be identical. Differences in readings may be due to a sprung set shaft, to a worn rack and pinion, or to loose or worn keys on the pinion. Most mills provide for some adjustments, either by resetting the rack or by recoupling the segments of the set shaft, but worn parts need replacements.

(3) End play of the mandrel can be detected by trying to force it toward or away from the track by using a lever on the driver pulley.

c. Consistent Failure to Cut Boards of Similar Thickness.

(1) Inconsistent thickness may be due to causes already listed or caused by malfunctioning dogs, setwork, or saw. One source of inaccurate sizing is inherent in the setwork mechanism of many small mills. It may be caused by the pinion-rack connection being so loose that the knee can be moved backward or forward as much as 1/2 inch without use of the set lever. Such looseness also results from worn gears. With fast feeds this looseness can cause a light cant to pull toward the saw. Faulty sizing also results from play in the setwork gears or in the pawl contacts. Either is usually traceable to worn keys, cogs, or pawls. Faulty sizing may also be due to miscalculation by the setter or to lack of a fixed backstop. This makes it difficult to set the exact interval desired in the setwork.

(2) Faulty sizing from slack dogging shows up in fast feeds or when sawing cants that have unbalanced stresses ("springy" timber). Some types of dogs are better designed to hold the cant more firmly than others. The boss dog normally grips firmly and draws the cant tightly to the face of the knee. Dull tooth points, knots, or loss of the correct hook when the point is sharpened may also result in faulty sizing.

(3) The saw can be the source of faulty sizing if the mandrel has end play, if the lead is not correct, or if the fitting of plate or teeth is incorrect. If any of these conditions are present, the saw has a tendency to deviate when overloaded, as when using excessively fast feeds, cutting hard or frozen woods, or making deep cuts. A dull saw is more erratic than a sharp one.

9-16. Tallying and Grading

a. Tallying. A daily tally of green lumber cut at the mill is kept by small mills. As a rule, small mills depend upon recording the amounts of product shipped out of the yard and the amounts in the yard as shown by periodic inventories. Large mills usually record the daily production at the green chain (conveyor which carries finished lumber to the loading dock). If the product is shipped green, the number of truckloads is recorded.

b. Grading. Usually all species are lumped together, but a series of tally sheets may be used where separate tally by grade and species is possible. At some mills where edging is done on the headsaw, the sawyer records items on a tabulation sheet. Headings are written in for each size (length, thickness, and width) normally sawed and a dot placed for each item sawed. Footage is computed from these records.

Section IV. SAFETY

9-17. Introduction

This section discusses the proper location of a sawmill and its cautious operation to avoid accidents. It notes the hazardous parts of the sawmill and explains how each part is operated safely. It lists the safety regulations to be observed by the sawmill crew and the repairmen.

9-18. Sawmill Safety

a. When selecting a sawmill site, avoid soft or spongy ground. The trackway, husk, and foundation timbers must remain absolutely level after

the sawmill is erected. If any part of the sawmill settles lower than the other parts, it may cause serious trouble.

b. When the headsaw is operating, always secure the sawyer's lever in the neutral position when it is necessary for the sawyer to leave his post. Swing the neutral stop rest to the left and against the sawyer's lever. This prevents the lever from being accidentally moved to either of the engaged positions.

c. Before running the carriage past the headsaw under engine power, always make sure there is

proper clearance between the headsaw and the three headblock bases. Push the carriage past the saw by hand to check clearance. Be sure the head is stopped when checking the clearance between the headblock bases and headsaw.

d. When removing or installing the headsaw, use heavy gloves if available. If gloves are not available, use pieces of heavy canvas or other cloth to protect the hands from injury by saw teeth.

e. When operating the cutoff saw, make sure that footing is secure. If footing is slippery, place heavy boards on the ground and across the dust hole, and be sure that they are not slippery or become a stumbling block.

f. Do not apply nonslip belt dressing to the feed belt or backing belt. These belts must slide freely on the pulleys when the the sawmill is idling.

g. Do not attempt to stop a board already started into the front feeder rollers or to change its course. This may result in injury to personnel or damage to the equipment.

h. Do not use the pawl release lever to stop the receding action of the knees. This harmful practice will throw unnecessary strains on the setwork parts and cause rapid wear on pawl holders and the ratchet wheel. Always use the brake to stop the knees at the desired position.

i. Every time the adjusting screws for the seven V-type drive belts are disturbed, be sure to check the mandrel for alinement.

j. Safety should be the first consideration in sawmill operation. The sawyer, as well as the entire crew, must constantly be on the alert to avoid accidents which would cause injury to himself or to others. Every crew member should avoid forming careless operating habits which cause unnecessary wear and tear on the working parts of the sawmill. To prevent accidents, the sawmill crew should follow these safety rules and suggestions.

(1) Keep trash, rags, and tools from carriage platform.

(2) Keep knots, slabs, or tools from husk cover box.

(3) Do not allow slabs to accumulate around edger.

(4) Keep slabs, boards, and knots from trackway.

(5) Make sure the carriage foot guards are fastened tightly at all times.

(6) Sawyer must never remove hand from sawyer's lever when saw is running unless the neutral stop is holding the lever in neutral position.

(7) Always keep the husk cover box on husk when cutting lumber.

(8) Avoid working too close to the edger drive belt and feed belt.

(9) Avoid wearing loose, ill-fitting clothing when working near saws, belts, or pulleys.

(10) Always wear gloves when handling saws, tools, equipment, and timber.

(11) Avoid piling too many logs on log skid.

(12) Avoid careless piling of crooked logs which might roll into personnel or equipment.

(13) Use cant hooks and peavies to move and handle logs. Do not use hands, feet, or timber sticks for this purpose.

(14) Use wedges or blocks to prevent logs from rolling into equipment.

(15) Keep walkways clear of bark, slabs, knots and tools.

(16) When sawing logs with loose bark or with loose splinters, place the safety screen between headsaw and sawyer.

(17) Avoid careless operating habits which might result in tripping and falling into saw.

(18) Do not operate the cutoff rig unless the guard box is installed.

(19) Do not handle logs with broken, damaged, or dull cant hooks. Keep hook points sharp.

(20) Do not burn slabs or dust close to the sawmill.

(21) Do not install or adjust the saw guide pins while headsaw is running.

(22) Do not crawl under or over the power unit universal joint when the saw is in operation. Build a box guard and steps over and around the universal joint, and a skeleton guard at the side of the edger drive belt.

(23) When sawing at night, make sure the sawmill is sufficiently well lighted to permit safe operation.

(24) When removing small splinters or bark from the husk cover box near the saw, use a long stick, not the hands.

(25) Do not walk on the husk cover box while the saw is running.

(26) After installing the sawmill, run the carriage past the husk by hand before operating it under power.

(27) Do not operate the saw when the belts are only partly connected, or when the connecting pin is broken or damaged.

(28) Make sure large crooked logs are securely dogged before starting the cut. This type of log is liable to break away when the saw is part way through it unless the log is held firmly in place. Such a breakaway may injure personnel as well as damage equipment.

(29) Always watch for imbedded metal objects in logs. Spikes, wires, lag screws, or shell fragments should be chopped out. Better yet, do not saw this part of the log.

(30) Make sure the saw guide is in place before starting a cut. All drive belts and pulleys must be adequately guarded.

(31) If a knot of a slab becomes caught in the edger rollers, do not attempt to dislodge it with the edger running. Stop the sawmill.

(32) Do not try to run badly split or shattered boards through the edger.

(33) Do not remove heavy knots or slab ends wedged between headsaw and husk cover box by standing on top of cover box. Stay away from saw, and either use a cant hook or stop the saw.

(34) Do not kick off the last board (backing board) when carriage has started back and is too near the saw. Make sure the backing board does not fall into the saw.

(35) The sawyer should not operate the sawmill unless he is in good physical condition.

(36) The sawyer is responsible for the safety of the entire crew, especially those on the car-

riage. Hence, the sawyer must avoid careless operating habits such as jerky, uneven application of the sawyer's lever. This practice may throw crew members off balance and into the saw.

(37) Before starting any repairs on the sawmill, stop the engines. Remove the battery connections to prevent accidental or unauthorized starting of the engines.

(38) The frequency of fires in mills is very high, and the control of fire hazards must be a continuous effort.

9-19. Saw Safety

- a. Never saw with a dull saw.
- b. Never saw with a hot saw.
- c. Do not allow chips to rub saw.
- d. Keep saw clean of pitch. Pitch sticks only to a hot saw.
- e. Always carry extra teeth for the saw and be sure to place them in oil before putting them in the saw.
- f. When handling saws always wear heavy leather gloves. Keep all parts of body protected when filing or handling saw blades. Wear protective clothing, including safety shoes, if available.
- g. Use two men to handle and carry large-diameter saws.
- h. Use goggles or face shield to protect eyes from flying chips or particles and when grinding or gumming with a power-driven emery wheel.

Section V. OPERATION OF CIVILIAN SAWMILLS BY ENGINEER UNITS

9-20. Operation

The most desirable method of operating a civilian sawmill taken over by the military is to allow indigenous personnel normally employed at the mill to continue its operation. A member of the forestry company should be assigned to the mill as an administrator and expeditor. The mill personnel may be paid by the Army to operate the mill without remuneration for the lumber sawed, or the civilian operator may sell the lumber to the Army at current local prices. It may be necessary for the Army to supply fuel and repair parts to the civilian mill operator.

9-21. Maintenance

Because of the different size standards used in manufacturing equipment it will seldom be found

that United States manufactured sawmill parts will interchange with any of those of a foreign sawmill. In some instances, headsaws may be interchangeable on circular sawmills, with minor modifications. Therefore, immediately after the sawmill is acquired plans should be made to set up a supply system for parts. Information for normal lubrication, adjustments, and inspections should be obtained from indigenous personnel employed at the mill. As soon as possible, standard military preventive maintenance practices should be enforced.

9-22. Rehabilitation of Civilian Sawmills

Usually, the best method of rehabilitating a sawmill is to move all salvaged parts into a well equipped maintenance shop. Before starting the

job a plan should be made of the contemplated unit. This plan should utilize the equipment available in assemblies. A military type power unit can be attached to a civilian type sawmill husk with only minor modifications to the power takeoff of the power unit. The greatest difficulty in rehabilitating civilian units in wartime is the lack of spare parts. Therefore, unless a well equipped machine shop is available, a "patched-up" sawmill can be a source of many breakdowns and work stoppages.

9-23. Safety Precautions in Operating Civilian Sawmills

a. *General.* Immediately after the civilian saw-

mill is taken over, the safety program should be put into effect. The same safety precautions listed in paragraphs 9-18 and 9-19 should be observed in the civilian sawmill.

b. *Faulty Equipment.* Many small civilian sawmills are usually kept in operation with inferior parts and maintenance methods which cause frequent breakdowns. Equipment breakdowns constitute a loss of time and manhours, a hazard to operating personnel, and limited production. Constant inspection of the equipment is necessary in order to avoid accidents caused by faulty equipment.

Section VI. OPERATION UNDER UNUSUAL CONDITIONS

9-24. Operation in Mud and Water

a. *Reinforcing Foundation.* If it becomes necessary to operate the sawmill in mud and water, use precautions to prevent the foundation from settling unevenly. Before operating the sawmill, level the trackway, husk, edger, cutoff rig, and power unit. If necessary, excavate under the foundation and block up by using boulders, stones, bricks, or heavy wood blocks.

b. *Drainage.* Dig drainage ditches to remove excess water from sections of the sawmill site. Use pumps if they are available.

c. *Belts, Ropes and Pulleys.* When closing down for the day remove flat belts, roll them up, and cover them if rain is probable. Cover flat surfaces of pulleys to prevent rust and corrosion. Remove rope drives if they cannot be adequately protected with covers.

d. *Saws.* Remove the headsaw and place it under cover to prevent rust and corrosion. Put waterproof covering on the cutoff saw and edger husk to protect the saws and edger parts, especially the saws. If no covering is available apply oil or grease protective compound to the saw faces and bits.

e. *Walks and Platform.* If mud is excessive, build walks and platforms for the sawmill crew with lumber or other material available.

9-25. Operation in Cold Weather

a. *Frozen Timber.* The sap in green timber

freezes in temperatures below 32°F. Under these conditions it may become necessary to service saw bits and teeth especially for frozen log conditions. Usually, saws should be set the same as when used for extremely hard wood.

b. *Ice on Equipment.* Precautions should be taken to prevent ice from forming on the trackway, carriage wheels, husk, and edger.

9-26. Operation on Uneven Terrain

If it becomes necessary to erect the sawmill on a steep slope or across a ravine, pay particular attention to the sawmill foundation. Use heavy supply posts and brace them well by using 2- by 6-inch or 2- by 8-inch boards. If support posts are used in soft terrain, place heavy blocks or boulders under the posts to prevent settling.

9-27. Night Operation

Lighting for the sawmill must be distributed evenly around the entire sawmill. The lights should be mounted high enough not to reflect in the operating personnel's eyes. It is also advisable to see that shadows are not cast on moving parts of the sawmill. A small spotlight situated so that the sawyer can easily see the butt of the log on the carriage will greatly aid in accurate sawing. Wires for night lighting must not be run on the ground or strung where loading or unloading equipment might damage them. All lights near the saws should be adequately protected from flying chips and debris.

CHAPTER 10

CARE AND MAINTENANCE OF SAWS

10-1. General

Personnel assigned to the care and maintenance of saws must know the types of saw teeth, how they perform in the cutting operation, and how they are kept in proper condition for sawing. This chapter is concerned primarily with the care and maintenance of headsaws. This information is generally applicable to other types of saws as well.

10-2. Saw Teeth

In order that a saw may function effectively, the saw teeth must be spread so as to make a channel that is wider than the thickness, or gage, of the saw plate. Two types of teeth are in common use to meet this requirement—spring-set teeth, and swage-set teeth.

a. Spring-Set Teeth.

(1) Spring-set saws are normally used as trimmer, straight line cutoff, and slasher saws which function as crosscut saws (cutting across the grain).

(2) In the spring-set type, the teeth are bent outward, alternate teeth in the saw direction and adjacent ones in opposite directions.

(3) In circular crosscut saws, the outline has zero or negative hook; that is, the radius from the point coincides with or is behind the cutting edge of the tooth.

(4) Crosscut bands with a spring-set, rip type of tooth are rarely used for crosscutting logs on deck.

b. Swage-Set Teeth.

(1) Swage-set saws are used for cutting parallel to the grain (ripping). Swage-set teeth, if properly fitted, cut out small chips of coarse cube-shaped, rather than fine, sawdust.

(2) In the swage-set type, the plate is spread at the cutting zone of each tooth.

(3) In all classes of headsaw (gang, band, and circular) the rip tooth has a hook; that is, the front outline of the tooth, from its point to the

throat of the gullet, lies behind a perpendicular extending from the point to the saw back in band and gang saws, or behind the radius to the tooth point in circular saws.

(4) Swage-set teeth may be solid, that is, cut from the plate, or inserted or fixed to the plate with special holders. Normally, inserted teeth approximate the degree of hardness of the plate, but harder teeth or cutting parts are available. Inserted points of high speed steel normally cut several times as much between sharpenings as do standard teeth. Still harder alloys, usually shaped to form cutting parts and welded or brazed to solid or inserted teeth, are coming into use. These normally function for several days or weeks between sharpenings, but are brittle and subject to damage from metal or rock. Special equipment is required for sharpening them.

(5) Inserted points on saw teeth and tooth holders are not produced uniformly by the different manufacturers. Table 10-1 lists the style symbols used by specific manufacturers for a given style. All symbols horizontal in the given column identify interchangeable products. The difference in styles includes not only the shape of the gullet, as shown in 1, figure 10-1, but also the holder and tooth, as shown in the three major variants (2, fig 10-1).

(6) Resistance to cutting increases with chip thickness and saw speed, with a change from a species of low density to one of high density, with knotty material, with progressive dulling of the teeth, and with increasing depth of the sawed face. Sufficient resistance can be built up to cause the saw to jam or deflect under extremes in any of these conditions. Without data on the force required to deflect a saw under given conditions, knowledge on what the saw will take can be gained only through use.

10-3. Factors Affecting Selection and Use of Saws

Many factors affect the selection and use of saws. Among these are saw diameter, which largely de-

Table 10-1. Interchangeability of Inserted Point on Teeth and Tooth Holders
(Tooth and holder numbers on the horizontal line are interchangeable)

Saw Part	Manufacturer's name and part No.								
	Atkins	Corley	Disston	Hue	Lippert	Ohlen-Bishop	Simonds	Southern	Spear and Jackson
Teeth	2		4½D	2	2		2	2	
Holders	2		4½D	2	2		2	2	
Teeth	2½	2½	2½	2½	2½	2½	2½	2½	2½
Holders	2½	2½	2½	2½	2½	2½	2½	2½	2½
Teeth	3	3	3	3	3	3	3	3	3
Holders	3	3	3	3	3	3	3	3	3
Teeth	3½		3½	3½			3½		3½
Holders	3½		3½	3½			3½		3½
Teeth	4		8	4			4	4	
Holders	4		8	4			4	4	
Teeth	4½		4½	4½			4½		4½
Holders	4½		4½	4½			4½		4½
Teeth	5		9	5			5		
Holders	5		9	5			5		
Teeth	B			B			**B. D. F.	B. F.	B
Holders	B. D. F.	B. F.		B. D. F.			**B. D. F.	B. D. F.	B. D. F.
Teeth	*C	*3D	*3D	6				*3D	
Holders	*C		*3D	6				*3D	
Teeth	*33	*33	*33	*33				*33	
Holders	*33		*33	*33				*33	
Teeth			ABC						
Holders			A						
Teeth			ABC						
Holders			B						
Teeth			ABC						
Holders			C						
Teeth			***1						
Holders			50						
Teeth			***1						
Holders			55						
Teeth			***1						
Holders			66						
Teeth						1		1	
Holders						1		1	
Teeth						2P		2P	
Holders						2P		2P	
Teeth		22				22			
Holders						22			
Teeth			44	44				44	
Holders			44	44				44	
Teeth				25					
Holders				25					

*Atkins No. C and Disston No. 3D saws will take No. 33 teeth and holders, but neither Atkins No. C nor Disston No. 3D teeth can be used with No. 33 holders.
 **B. D. or F teeth will fit either B. D. or F holders, but a saw milled for a given holder by the manufacturer must be fitted with that holder (holders not interchangeable). This pertains to Simonds saws only.
 ***Disston "Single Ball Invincible" tooth.

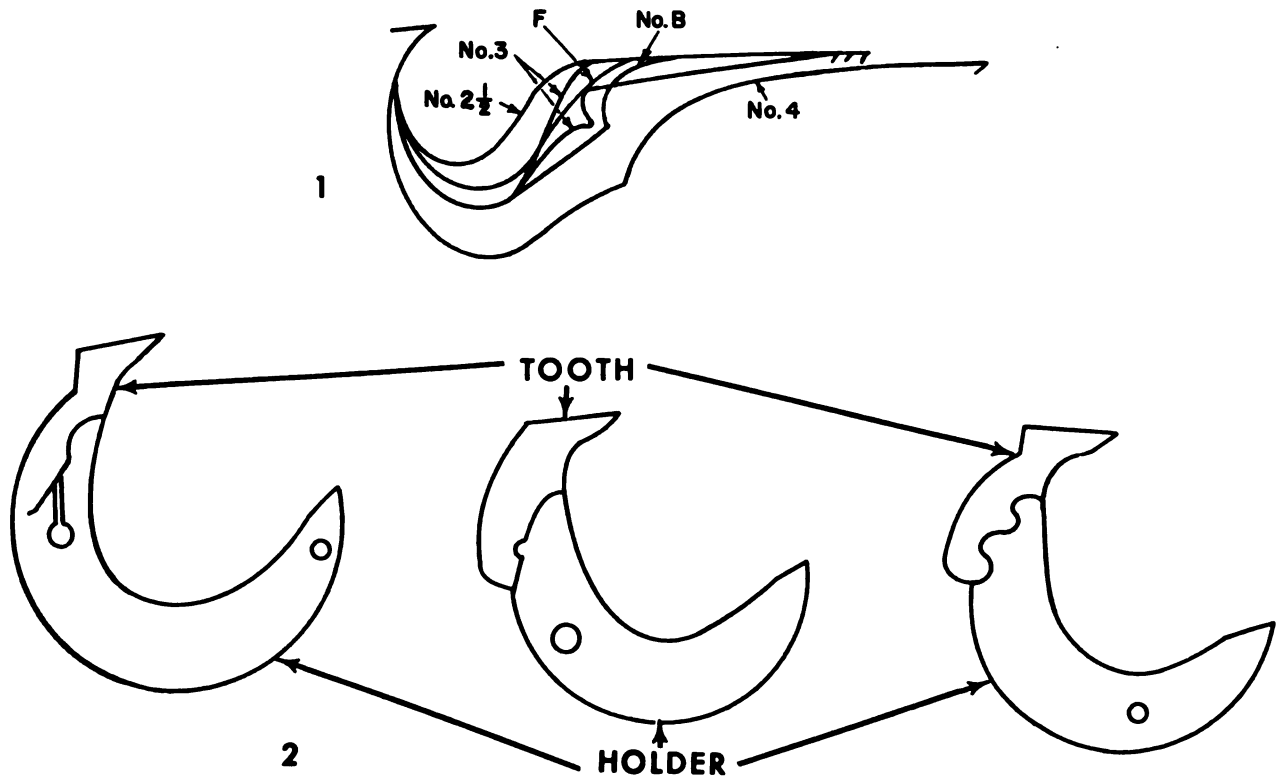

1 OUTLINE OF GULLET FOR COMMON STYLES OF INSERTED TEETH
 2 MAJOR VARIANTS OF STYLE IN HOLDERS AND INSERTED TEETH

Figure 10-1. Inserted saw teeth.

termines the size of log a mill can handle; saw gage, which varies with diameter but also to some extent with the density of the timber being handled; tooth pattern, including shape of gullets as well as points; tooth spacing; and saw speed.

a. *Diameter.* The diameter of the saw should not exceed that needed to saw up the larger logs. The relationship between the saw diameter and the diameter of the log that can be sawed by the standard method of sawing around the log is as follows:

Saw diameter (inches)	Log diameter (inches)
48	28
52	30
56	33
60	36

b. *Gage.* The extreme range in gage of circular headsaws used under normal conditions lies between 7 and 10, a difference of about 1/22 inch. Circular saws are usually beveled from near the collar to the rim, so that the rim is 1 or more

gages thinner than the center section. For solid-tooth saws, an 8-9 gage (8-gage center, 9-gage rim) is recommended for average conditions, with the alternative of a 9-10 gage for saws 50 to 60 inches in diameter when run at high rim speed (10,000 or more feet per minute). A 7-8 gage is generally used for 50- to 60-inch saws subjected to heavy loads, such as heavy hardwoods, or for feeds exceeding 1/22 inch per tooth. For inserted-point saws, the 8-9 gage can be used on all diameters up to 60 inches for general use. For use under heavy loads, an alternative for saws 48 inches or less in diameter is the 9-10 gage, and for saws 50 to 60 inches in diameter the 7-8 gage.

c. *Teeth and Gullets.*

(1) Ripping is most efficiently done by a chisel action and crosscutting by a knife action. Chisel action is easiest if the tooth tapers gradually from the cutting edge of the shank. In designing the headsaw tooth, the top face is carried back from the cutting edge to make as sharp an

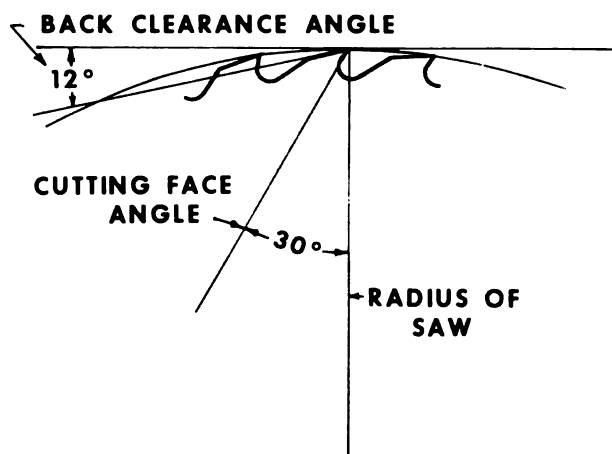

Figure 10-2. Design of tooth and gullet, showing proper clearance and hook angles for solid-tooth saws.

angle with the top face as possible and yet give enough body to the tooth to prevent noticeable vibration when cutting. In solid-tooth saws (fig 10-2) this cutting face normally makes an angle of 30° to the radius of the saw blade from the tooth point, although where heavy loads require a stronger tooth this hook angle may be as little as 15°. Inserted points are given more hook, approximately 41°. The rest of the tooth is shaped to provide the maximum gullet (rounded cavity in the saw plate in which sawdust accumulates and is carried from the cut) space consistent with an adequately supported point.

(2) The tooth should be only wide enough to assure clearance for the blade. Wider teeth put unnecessary strain on the saw, increase the chance that sawdust will work out of the gullet, take more power, and waste more material. In saws of 7—10 gage, at least 3/32 inch in addition to the blade thickness should be allowed; 4/32 inch is commonly used on the solid-tooth type for softwoods. For hardwoods or frozen timber, 1/64 inch less than the above stated allowances is recommended.

(3) Inserted points, which are narrowed back from the cutting edge, are not commonly swaged beyond the swage given them by the manufacturer. Repeated sharpening shortens the inserted tooth, thus continually narrowing the cutting edge. The new tooth, therefore, has excessive clearance (5/32 inch) in order to lengthen its service life. Cutting takes place not only along the cutting edge but back along the edges of the lower face for a distance usually between 3/32 inch and 6/32 inch, depending upon the size of chip taken. Hence, these edges must be carefully machined and dressed.

d. Spacing of Teeth.

(1) The gullets of saw teeth must have a curved outline (angles or corners in the gullet foster cracks) with an area ample to carry the sawdust yet with a strong backing to the tooth proper. The gullet space required to carry the sawdust limits the number of teeth that can be put in the saw.

(2) The capacity of the gullet to carry sawdust is always a limiting factor in determining power requirements for a saw. A feed rate in excess of gullet capacity results in miscut lumber and a jammed saw. Miscut lumber is lumber having a variation in thickness between any two points along its length.

(3) It is assumed that the gullet area must be twice that of the wood removed. This is a general approximation for all types of wood, and does not consider the variation in packing quality of sawdust as related to its density. The cross-sectional area of the gullet can be measured by outlining the gullet profile (fig 10-2) included under a straight line from point to point of consecutive teeth on a paper having lines making 1/4-inch squares. Each square thus equals 1/16 square inch. The cross section of the amount of wood is the bite per tooth multiplied by the cutting depth.

(a) The bite per tooth for a stated cutting depth which fills the gullet under the 2 to 1 assumption is found by the formula—

$$2 \text{ bites} \times \text{cutting depth} = \text{gullet area.}$$

Thus, for a cutting depth of 20 inches and a gullet area of 2.5 square inches, the bite is 0.0625 inch, which equals 16 teeth per inch of feed.

(b) The feed rate up to overloading, in terms of feet per minute, is—

$$\frac{\text{Number of teeth in saw} \times \text{saw rpm}}{\text{Number of teeth per inch of feed} \times 12}$$

For a bite taking 16 teeth per inch on a saw with 48 teeth running at 550 revolutions per minute, the feed rate is—

$$\frac{48 \times 550}{16 \times 12} = 137\frac{1}{2} \text{ feet per minute.}$$

(4) For normal work, inserted-point saws have approximately one tooth for each 3-1/4 inches of rim, solid-tooth saws one for each 2-1/2 inches. With fast feeds, gullet requirements raise the limit for solid-tooth saws to about 3 inches.

e. Saw Speed and Chip Thickness.

(1) The usual instructions that saw speed should be no greater out of the cut than can be maintained in the cut are inadequate without consideration of feed rate. Output hinges on feed rate, on the thickness of the chip taken per tooth, and on saw speed. In small mills, the feed rate ranges between 1/24 and 1/8 inch per tooth. A relatively thick chip is obviously desirable; it gives greater production with less wear on the cutting edge and corners of the tooth, and makes coarse sawdust that is less prone to crowd out of the gullet. At most mill setups, a thick chip also results in more efficient use of horsepower.

(2) A thicker chip results when the number of teeth in the saw is reduced, when the carriage feed rate is increased, or when the saw speed is reduced. In underpowered mills, the carriage feed rate usually cannot be increased; for such conditions, a saw with fewer teeth or one run at a reduced speed should prove more efficient. Given plenty of power, the carriage feed rate can be increased to the capacity of the gullets to carry sawdust. For additional increased production, both the carriage feed rate and the saw speed can be increased. The increased loads resulting from higher saw speeds and feed rates, however, require heavier equipment in the carriage and saw mechanism.

10-4. Tensioning Saw

a. *Purpose of Tensioning.* Forces acting to stretch the rim of a circular saw are centrifugal force (outward pull of the revolving plate), resistance to cutting, and heating of the saw when grinding out its gullet ("gumming" it). These are enough to expand the rim so that the saw will fail to hold to a true line unless it is properly treated. By stretching the midradial area uniformly, that is, tensioning it, the rim is steadied, so that the saw holds a true line. The midradial area is that area of the entire saw which lies one half the distance between the saw's center and its perimeter. This area, for the purpose of tensioning, is fairly large and is explained in e(2) below.

b. *Amount of Tensioning.* The amount of tension given this midradial zone is governed by certain considerations. A large saw requires more tension than a small one; a thin saw more than a thick one; a high speed saw more than a low speed one; and a heavily loaded saw more than one under light load. The measure of tension is the extent to which the midradial zone sags below a straight-edge held on the radius when the saw is supported as shown in figure 10-3. This sag may be as little as 1/75 inch on small, slow speed head-saws, or as much as 1/12 inch on large, high speed ones, since the amount of sag determines the ex-

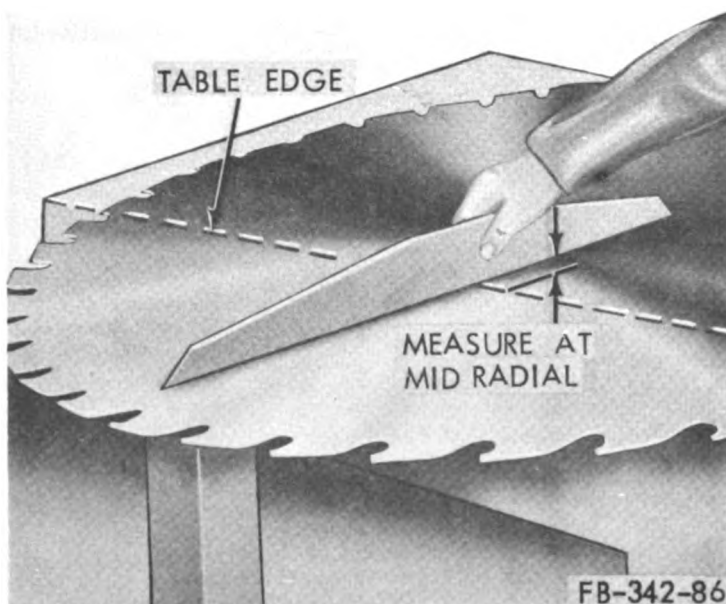

Figure 10-3. Method of measuring tension in a circular saw.

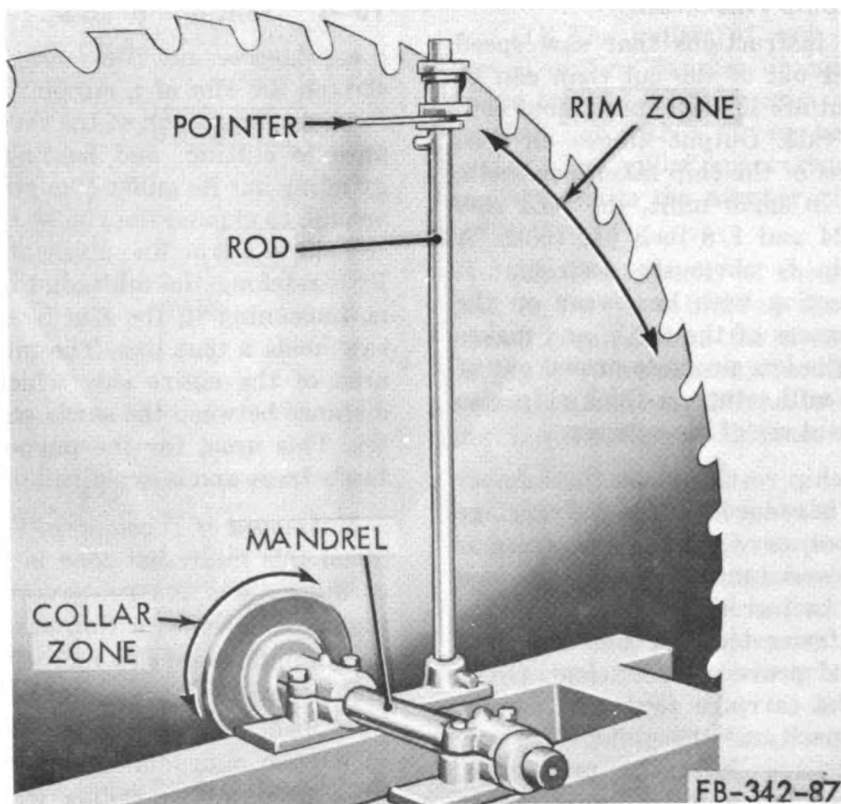

Figure 10-4. Trial mandrel.

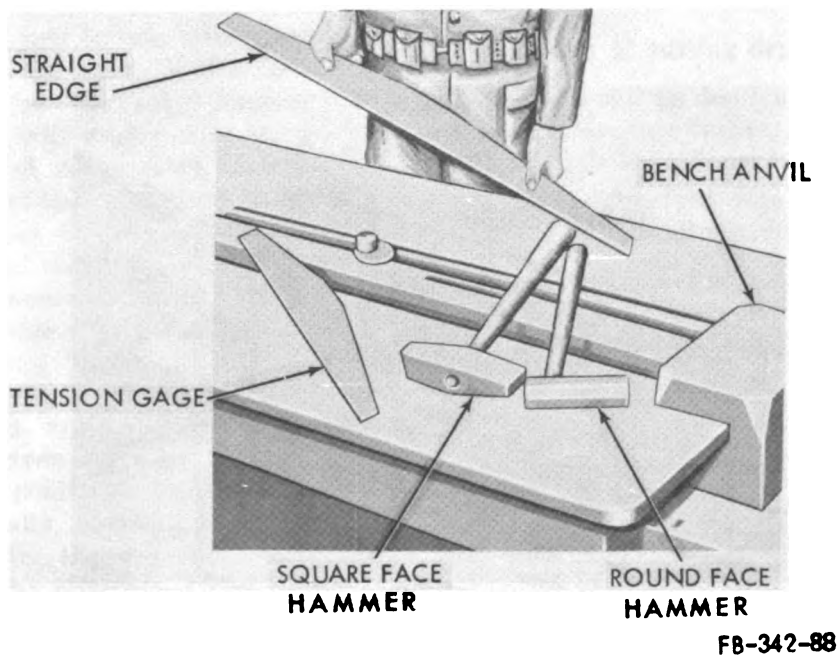

Figure 10-5. Equipment for tensioning saw.

tent to which the rim of the saw can expand without deviating, as discussed in *a* above.

c. Tensioning by Hammering. Where and how much to hammer must always be a matter of judgment for each tensioning. This can only be acquired by experience.

(1) *Tools needed.* The tools suggested are a trial mandrel (fig 10-4), a hammer bench with running board or back rest, a 150-pound anvil with crowned face, a 4- or 5-pound square-faced hammer, a 4- or 5-pound round-faced hammer, straightedges 6 and 60 inches in length, and a tension gage (fig 10-5). The 6-inch straightedge is used to determine the size and shape of small, localized high areas. The 60-inch straightedge is used to determine whether or not the saw is tensioned evenly over its entire surface. The tension gage is a straightedge altered to conform to the arc of curvature when the properly tensioned saw is tested for "drop." A headsaw gage can be made by dressing the edge of a thin strip of steel to fit exactly the arc of curvature of the correctly tensioned saw. When the saw is given the tension test, one end of the gage is placed about 4 inches from the bottom of a gullet and the other end about 4 inches from the eye (center hole) of the saw. One end of the gage is marked so that the same end can be placed at the rim in all tests. Neither the gage nor the straightedge should be allowed to lean from the upright position. They should be pressed gently against the plate.

(2) *Leveling saw.* To put a saw in condition, check for twists, lumps, and other high spots. Level these imperfections. Then put in the correct tension. The gage will indicate where to hammer for correct tension. To get background on the degree of uniformity sought in a properly leveled saw, put a correctly leveled and tensioned one on the trial mandrel, fix the pointer (fig 10-4) so that it barely clears the plate about 1 inch below the base of the gullet, and then slowly turn the saw, noting the degree of variation in the gap between the plate and the pointer. Check for uniformity at 2-inch intervals along a radius from the rim to the collar line.

(3) *Use of trial mandrel.* The trial mandrel (fig 10-4) must be flawlessly straight and held true in the bearings; saw collars must be perfectly fitted and planed. The rod to which the pointer is attached should be parallel to the planed faces of the collars.

(4) *Practice in striking saw.* To learn how hard to strike a saw for tensioning purposes, spread a film of oil over an area of a discarded

saw and place the saw on the anvil. Practice striking it until the face mark left by a round-faced hammer is maintained at a 7/16-inch diameter. This diameter should never be greatly exceeded; one of 5/8-inch indicates excessively heavy blows. In leveling, blows are ordinarily less severe than in tensioning, since leveling is preparatory to tensioning and must not impart any tension but only correct uneven surfaces.

d. Procedure for Finding High Areas. Put the saw requiring fitting on the trial mandrel. Turn the saw slowly and, where the gap between pointer and plate diminishes beyond the standards set up previously, draw a short chalk line on the plate. Repeat for each of the concentric circles 2 inches apart. The result should be a series of marks indicating areas of high spots. In some cases, high spots are indicated by particularly bright metal; in extreme instances, the metal may be blued by heat generated in sawing.

(1) *Confirming location of high areas.* These marked areas result from lumps and twists in the saw and must be hammered out. Before the saw is taken from the trial mandrel, confirm the extent and direction of these high spots by placing a 6-inch straightedge against the plate in such a way that it is centered on a marked high area. By sliding the straightedge in different directions over it, the size and shape of the high area can be correctly delineated and marked.

(2) *Hammering technique.* Put a double sheet of wrapping paper over the anvil, place the eye of the saw in the socket with the marked side of the saw up, and center one of the spots on the anvil. In all hammering, whether for leveling or tensioning, move the saw as needed to bring the anvil squarely under the blow. Circular high spots can be taken down with either the round or the square-faced hammer. Strike blows beginning at the center of the area and following a line to the margin. Space the blows about an inch apart, and taper off on the force of the blows in approaching the margin. Place succeeding series of blows on lines from center to margin, as in the first case. Be careful that the blows are no harder than needed. Too heavy pounding drives the high spot beyond the level condition and complicates later tensioning. Do not expect to level the lump completely the first time over the saw. In using the square-faced hammer, a second blow is always struck directly over and at right angles to the first.

(3) *Eliminating twists.* To eliminate twists, center the area over the anvil and hammer it so

that the long axis of the square-faced hammer is along, rather than across, the twist. Blows are spaced about an inch apart. The first line hammered should conform to the axis of the twist. Follow up by hammering a series of lines on each side if the width of the raised area indicates the need. Level the mid-zone area of the circular saw. Do not hammer the area inside the collar line or the 4-inch zone next to the base of the gullets.

(4) *Rechecking high areas on trial mandrel.* Having gone over the areas indicated to be in need of hammering, put the saw on the trial mandrel with the other face to the pointer, and mark the high spots as before. Hammer out these areas that require leveling. Take off the chalk marks from the saw, and repeat the process of remarking and hammering until the saw is properly leveled.

e. Determining Tension Attained. The saw is now ready to be checked for tension. With the saw on the trial mandrel, place the long straightedge firmly across the plate as close to the diameter as permitted by the collar. This diameter-wise application of the straightedge is repeated on six diameters equally spaced to divide the circumference into 12ths. The saw is evenly tensioned when the straightedge contacts it over its entire length at all checks. The initial checks will usually disclose high and low areas.

(1) *Hammering out remaining high areas.* Low areas indicate relatively great tension, and they should be outlined, but not hammered. The rest of the plate may contact the straightedge throughout the diameter, or unlevelled lumps or twists may show as localized high spots. Mark and level these twists. Eventually the straightedge will be completely in contact except at the low areas.

(2) *Use of concentric circles and radii.* Inscribe a series of concentric circles centered at the eye, the outer one about 4 inches from the base of the gullets and the others at 3-inch intervals until within about 2 inches of the collar line. For saws run at less than 700 revolutions per minute, draw radii to alternate tooth points; for saws run at higher speed, draw radii to each tooth point. The intersections of the radii and the circles are the spots to hammer.

(3) *Leveling along radii.* Place the saw on the anvil as for leveling, but without the paper cushion mentioned in *d(2)* above. With the round-faced hammer, strike a single blow at each intersection, starting near the collar line and progressing along the radius toward the rim. Then follow the next marked radius from the rim

toward the center. Continue this until all intersections to be hammered have been treated.

f. Uniformity of blows. For uniformity of blows, the tensioner is given the single job of hammering the plate. A helper at the bench side pulls or slides the saw between blows, so as to bring consecutive marked intersections over the center of the anvil. The saw is moved at a uniform rate in order not to interrupt the steady, even tempo required for uniformity in hammering. The tensioner stands in the position best suited to the individual for accurate hammering over the center of the anvil.

g. Leveling Opposite Saw Face. The saw is next marked on the opposite face with the identical pattern of radii and circles, so that hammering is done directly over targets on the reverse side. A single blow of equal force is given at each marked intersection.

(1) The saw is then placed on the bench and checked with the gage for uniform tension. Areas in need of further hammering are marked.

(2) This gage check is done by supporting one edge of the saw on the bench and raising the opposite edge so that the saw is supported only by the body and bench, and steadied by the left hand.

(3) With the right hand, the gage is placed on a radius exactly halfway between the bench and hand supports. This determines the degree of conformity between the gage edge and the saw plate.

(4) If the gage touches at the midzone but not toward the ends, further tension is required for that area. If the end zones touch but light shows under the midzone, the midzone should not be hammered, since its tension is now correct.

h. Further Hammering. Blows are struck at the intersections of radii and circles as before, but only in those areas showing need of additional tension. These blows usually are lighter. It is good practice to stagger the second series of blows from the original ones by placing circles and radii midway between those marked for the first treatment on the opposite face.

i. Final Check for Uniform Flatness. When the plate fits the gage on all radii, put the saw on the trial mandrel and again check the plate for uniformity of flatness by placing the long straightedge as close to a diameter as the mandrel nut allows. The plate should touch the straightedge throughout. If high or low spots show up, they are usually due to lumps. If in the rim or collar zone,

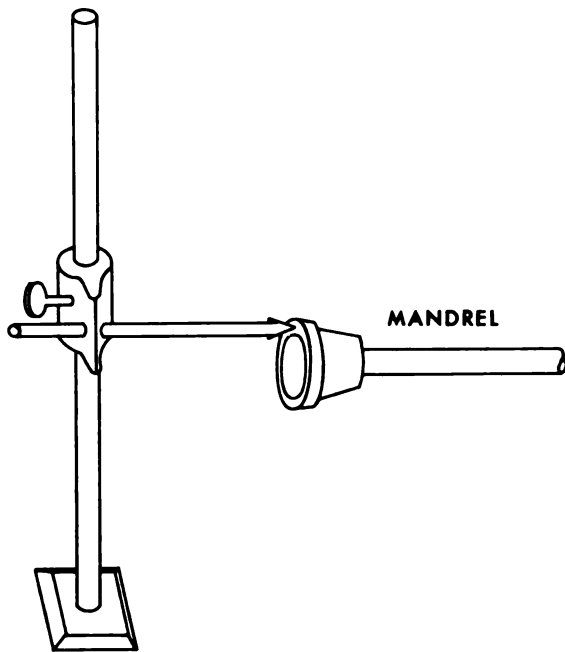

1 FIXED POINTER FOR CHECKING ALINEMENT OF MANDREL COLLAR

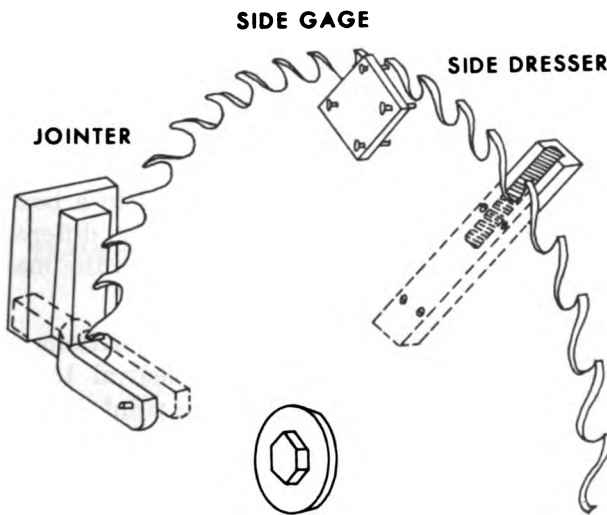

2 TOOLS FOR ALINING SAW

Figure 10-6. Alinement of saw.

these can be located by using a 6-inch straightedge while the saw rests flat on the anvil. Otherwise, the 60-inch straightedge must be used with the saw on the trial mandrel. Hammering inside the collar line or at the rim zone must be done very carefully and only after thorough checks indicate that other zones are properly leveled and tensioned.

10-5. Alinement of Saw and Teeth

A saw that is properly alined and tensioned cuts faces without visible scourgings. Scouring wastes

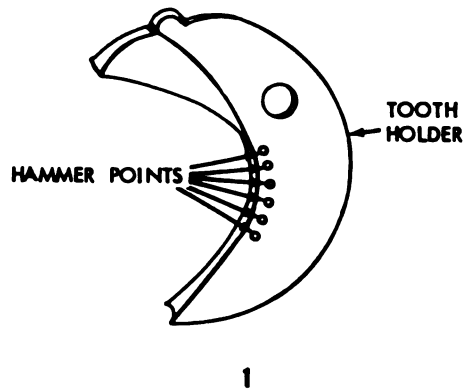

1

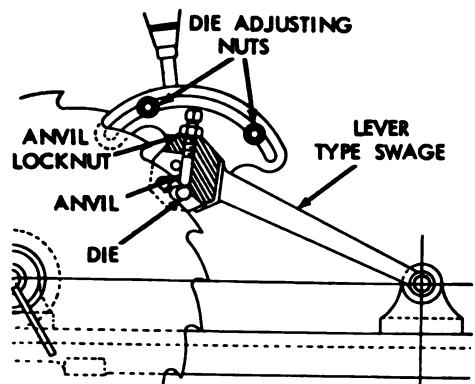

2

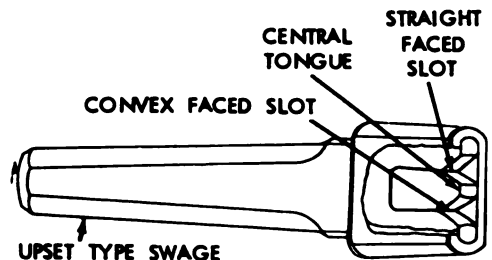

3

FB-342-90

- 1 Small circles indicate where to hammer tooth holder to stretch it
- 2 Lever type swage
- 3 Upset type swage

Figure 10-7. Tooth holder and swages.

both material and power. Tests indicate that approximately 10 percent more power is used in cutting scored faces than clean ones. Scouring results either because there is a flutter in the rim of the

revolving saw or because holders or teeth are out of line. The rim flutter may be due to faulty tension or faulty alinement of the mandrel or collars.

a. If the source of flutter is in the mandrel or collar, all saws will flutter. If the flutter persists even though the mandrel is held in place by its bearings, check the fixed-collar alinement.

b. The plane of the shoulder that bears on the saw plate should maintain, when the mandrel is turned, a uniform spacing with reference to a pointer that almost touches the collar (1, fig 10-6). If it does not, the collar should be ground.

c. The alinement of holders and teeth can be roughly checked by inspection, or more precisely with a side gage (2, fig 10-6).

(1) Misalinement due to inaccurate placement of tooth or holder can usually be corrected by careful replacement after the contacts of tooth, holder, and saw are cleaned with an oiled rag. In more stubborn cases, they can sometimes be brought into line by tapping them lightly on the bulge side while holding a block against the opposite side.

(2) Misalinement due to sprung parts can be determined by inserting a tooth and holder that is in line with its own setting. If it is out of line, the tooth can be brought in line by putting a saw set on the plate just back of the heel of the tooth and pulling the tooth in line.

d. A loose holder can be stretched by placing it on an anvil and striking a series of blows with the round-faced hammer at points indicated in 1, figure 10-7, repeating this procedure on the opposite face.

10-6. Filing Circular Ripsaws

a. Filing, as an operation, includes sharpening, swaging, sidedressing, jointing, and gumming (grinding out the gullets). The method of filing circular ripsaws is determined by the hardness of the teeth. The teeth of standard solid-toothed saws can be shaped and swaged with standard saw-fitting equipment, and cutting edges can be maintained with a file or emery wheel. Likewise, standard inserted points differ only slightly in hardness from the plate and can be maintained by similar equipment. The high-speed steel inserted points are not subject to swaging nor can they be sharpened with a file, but require an emery wheel. Still harder alloys are shaped for the cutting parts and welded or brazed to inserted and solid types of teeth. These require special sharpening wheels and cannot be swaged.

b. The teeth of solid-toothed saws can be fitted by swaging, sidedressing, jointing, gumming, and filing to restore their shape; inserted teeth are chiefly filed or ground. It is usually unnecessary to swage inserted points, since the design insures adequate clearance (of tooth thickness to blade thickness) for the useful life of the tooth. If swaging of inserted points is attempted with the upset swage (3, fig 10-7), the teeth should be held in a discarded plate or section in order to avoid damaging the milled juncture of the plate with the tooth and holder. If the lever type of swage is used, the anvil must be carefully adjusted to avoid gripping the tooth too far back, since the hard points crumble or crack under excessive spreading.

c. Solid teeth are swaged and usually filed two or three times, after which their shape is restored by swaging, sidedressing, jointing, and gumming. For swaging, either a lever type of swage or an upset type is used.

(1) The lever type swage (2, fig 10-7) draws the front of the tooth out and flattens it between an anvil and die. The anvil is adjusted to bear squarely on the top of the tooth, and the die contacts the underface back of the cutting edge. The die is slightly eccentric, so that when turned with the hand lever, it flattens the metal at the end of the tooth. This swage is usually fixed to a bench for shop service or, with a slightly different frame, can be used when the saw is on the mandrel.

(2) The upset swage (3, fig 10-7) battens the point. If the upset is used, the central tongue should be above the point and the point inserted in the slot having convex faces, with the back of the swage held on a line with the back of the tooth. A single blow is struck lightly with a 1-pound hammer. Then, reversing the swage so that the central tongue is still above the point, the tooth is inserted in the slot with straight faces and hammered as before.

(3) After the tooth has been swaged, its sides may be given uniformity by sidedressing them with a file mounted on a block (2, fig 10-6). Blunt-end screws that can be adjusted pass through this block to keep the file the required distance from the saw plate; or uniformity can be obtained by using a shaper (1, fig 10-8) to pattern the sides of the swaged area by compressing the sides of the tooth between dies.

d. Jointing, which usually follows swaging, is done only to bring all teeth to a true peripheral

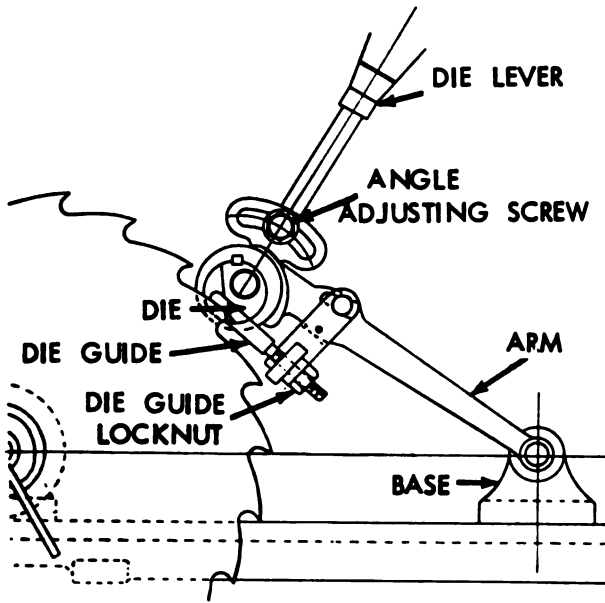

1

guide bracket. At first it should engage only the highest teeth; then it is advanced very slowly, until all teeth finally engage.

e. Gumming (the process of cutting out the gullets of a saw) is done with a power-driven emery wheel. Usually, provision is made for automatically grinding the desired tooth and gullet shapes progressively around the saw.

(1) In using such an emery wheel, burning of the saw metal must be avoided; that is, the wheel must not be forced against the metal so hard that the metal shows a blue tint. This is avoided by adjusting the emery wheel to grind the gullet lightly at first and not directly under the cutting edge; each gullet should be ground in this way before proceeding. Then the emery wheel is readjusted to deepen the gullet, and each gullet is ground until the wheel grinds the cutting edge of the tooth and completely around the gullet. Cutting parts of teeth that have been distorted by filing, wear, and swaging should be touched up with a properly adjusted wheel only after the throat and bottom of the gullet have been ground.

(2) Gumming with a round file is not usually

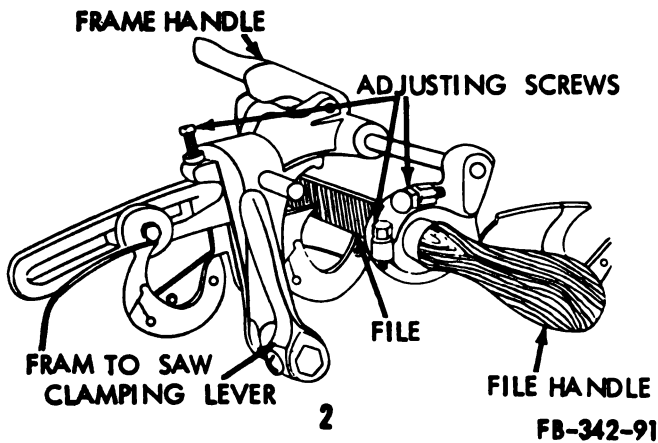

2

FB-342-91

1 Tooth shaper. 2 File in frame for sharpening teeth.

Figure 10-8. Tooth shaper and file frame.

circle. Before inserted points are jointed, holders and teeth must be tight and in the true plane of the saw. Jointing is done by bringing an emery stone or file against the cutting edge of the revolving saw. The stone, or file, is fixed to a block or base (2, fig 10-6) and is supported by the saw-

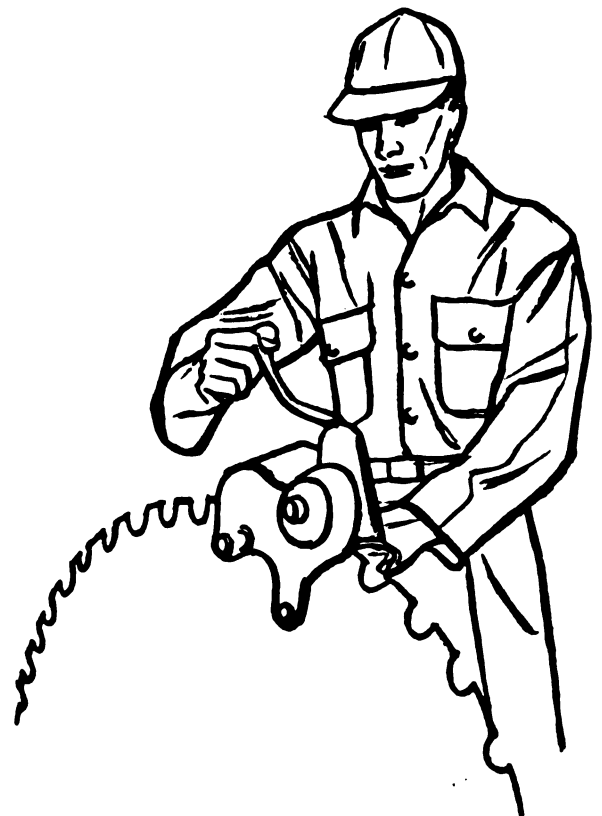

Figure 10-9. Tooth sharpening machine.

practical on headsaws because of the labor involved and the difficulty of maintaining uniformity of tooth shape and spacing. Gumming is done only on solid-toothed saws and requires emery wheels of specific pattern for that purpose.

Note. Gumming freehand with hand power grinder is not recommended. The use of specialized grinding equipment for such purposes is suggested.

f. Inserted points are usually sharpened with a file or emery wheel without removing the saw from the mandrel. Three machines are available for sharpening the saw on the mandrel.

(1) One consists of a frame supporting a standard file in position as in hand filing. Uniform surface contact is assured by means of frame supports as the file is pushed across the underface of the tooth (2, fig 10-8).

(2) The second consists of a frame that supports a hand-cranked wheel faced with file segments. The sharpener can be adjusted to surface the face of the tooth (fig 10-9).

(3) The third consists of a frame supporting an adjustable emery wheel to surface the face of the teeth. Power is supplied through a flexible shaft, by either handcranked gears or a motor.

(4) All three machines, when properly ad-

justed, permit facing the tooth squarely. The emery wheel can be set to grind a definite tooth spacing.

g. In filing by hand, individual skill instead of mechanical guides must be relied on to surface squarely across the underface on the plane in order to give the desired hook uniformly to each tooth.

(1) A round-edge, mill type file 8 to 10 inches long is recommended. The filer can work at the top of the saw or somewhat back of the top. When filing at the top, he stands on the track side, facing the saw with his shoulders at about 45° to the saw plane.

(2) The file is pushed full length straight from the shoulder without dropping the elbows. It is held firmly against the face of the tooth by gripping the handle with one hand and the point with the other.

h. In gaining experience, it is a good plan to first place the file against the face of a tooth so that the lower edge is free of the throat, noting the zone of the file face that can be used without touching the throat. Then about three strokes are taken and results studied.

(1) A stroke that was straight lengthwise of the file but was not in the same plane as the tooth face is indicated in 1, figure 10-10. This results in a slanting cutting edge (high corner).

(2) A stroke made when the plane across the file was not parallel with that of the tooth face is indicated in 2, figure 10-10. This produces a decreased hook.

(3) A stroke in which a rolling motion accompanies the thrust of the file, aggravating the dullness of a beveled face, is indicated in 3, figure 10-10.

(4) Filing should be practiced until consistency is acquired in stroking the full face, as in 4, figure 10-10.

i. In actual sharpening, about five strokes are taken per tooth. The number of strokes is varied according to the requirements of the individual tooth.

(1) Only enough metal is removed to restore sharp cutting edges.

(2) After the face has been filed, the cutting edge is tapped with the softwood handle of the file to remove the bur.

Caution: The back of the tooth should only be filed to remove distortion due to use of upset swage, never to remove the bur from filing. In

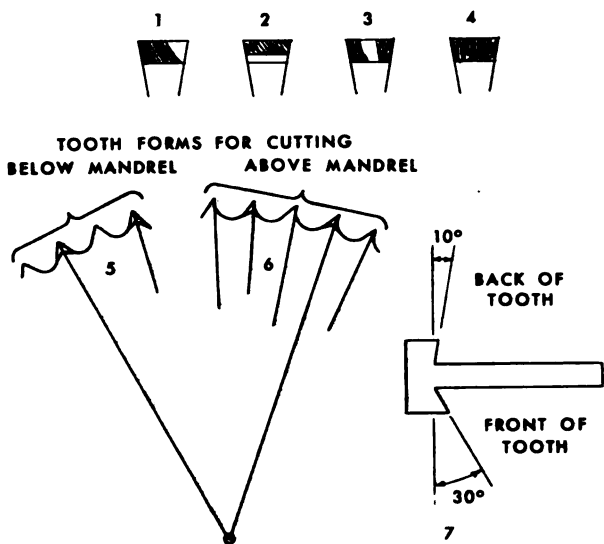

1. STROKE STRAIGHT, BUT NOT IN PLANE OF SAW TOOTH
2. STROKE NOT PARALLEL WITH PLANE OF TOOTH FACE
3. STROKE MADE WITH A ROLLING MOTION
4. FILE BEARS EQUALLY ON ALL PARTS OF TOOTH FACE
5. FORM FOR CUTTING DONE BELOW MANDREL
6. FORM FOR CUTTING DONE ABOVE MANDREL
7. GAGE FOR CHECKING FRONT AND BACK BEVEL ON TRIMMER SAWS

Figure 10-10. Filing patterns and trimmer saw gage.

filing the distorted tooth, extreme care must be taken to follow the back angle of the tooth. Otherwise the saw may "dodge" or "run" in the cut.

j. When filing a saw on the sawmill mandrel, the filer usually sits back of the saw and facing the deck, the saw being between the knees. The work is done at about shirt-pocket height. The stroke is parallel with the shoulders and more difficult to hold true than the straight thrust used in filing at the top of the saw.

10-7. Circular Crosscut Saws

Trimmer, straight-line cutoff, and slasher saws function by cutting across the grain. Teeth are spring-set except that in hollow-ground saws occasionally installed for smoothing and trimming, no set is used. To maintain teeth of uniform length, spacing (point-to-point distance), and shape, the saw should be jointed, the teeth spring-set and sharpened, and the gullets gummed.

a. Tooth forms used when cutting is done below or above the mandrel are illustrated in 5 and 6, figure 10-10.

(1) Tooth spacing is 1-1/4 to 1-3/4 inches.

(2) Tooth form 5, figure 10-10, is developed by dividing the rim into intervals equal to the desired tooth spacing and using each interval as the apex of a triangle having all sides equal.

(3) The base of the gullet is rounded out so that the tooth depth is two-thirds the point-to-point distance, and a bevel is given as shown in 7, figure 10-10.

b. Crosscut saws are often sharpened, set, and gummed with a power-driven automatic sharpe-

ner to insure that the correct shape and spacing of teeth are maintained. In filing, the guiding considerations are to keep the teeth of uniform length, shape, and spacing. The base of the gullet must be rounded and the face and back of the tooth beveled.

c. Several varieties of setting equipment are on the market that combine either a hammer-and-anvil or a vise-and-lever action. For straight-line cutoff and trimmer saws, 0.02- or 0.025-inch sets are suggested, and for slab saws a set with 0.03 inch on each side. The set should be started not more than 0.2 inch below the point. Uniformity in this point of departure and in amount of set is usually provided by the mechanism employed.

d. To sharpen the saw, the bevel is filed first, preferably with a round-edge file. An equal amount is taken from the front and back of the teeth in order to maintain the correct shape and height, as well as uniform spacing of the teeth.

(1) The knife edge extends down from the point 1/4 to 1/3 inch. For slab and straight-line cutoff saws, a bevel of 15° on the front and 10° on the back of the tooth is suggested. For trimmer saws it should be 25° to 30° on the front and 10° to 15° on the back.

(2) Guesswork can be eliminated by using a gage cut from heavy tin, as shown in 7, figure 10-10. Between the knife edge and the base of the gullet, the tooth is filed straight across sufficiently to maintain the correct outline, and the base of the gullet is deepened and rounded with a round file.

(3) Guidance for uniformity of gullet depth is gained by drawing a circle centered on the eye, with a radius not quite to the base of the gullets.

CHAPTER 11

LUMBERYARD OPERATIONS

11-1. Introduction

This chapter describes the procedures for operating a lumberyard. It discusses the lumberyard layout, the construction and use of lumber props for loading lumber on trucks, the process of sorting lumber, and the methods of piling lumber.

11-2. Lumberyard Layout

a. Green lumber, unless treated with chemical fungicides and insecticides, cannot be kept long without serious deterioration, principally in the sawwood. The speed and extent of deterioration

depend largely on temperature. Fungi and insects are active during warm weather, less active during cool weather, and dormant in cold weather. Research by the US Forest Service has revealed that when wood falls below 20 percent in moisture content, fungi cannot develop and the wood is less attractive to most insects. Consequently one way to avoid fungus and insect attack is to dry the lumber quickly, particularly the surfaces, to lower the moisture content.

b. The product of small sawmills is kiln dried. Seasoning is done, if at all, in an air-drying yard. Figure 11-1 shows a sample lumberyard layout.

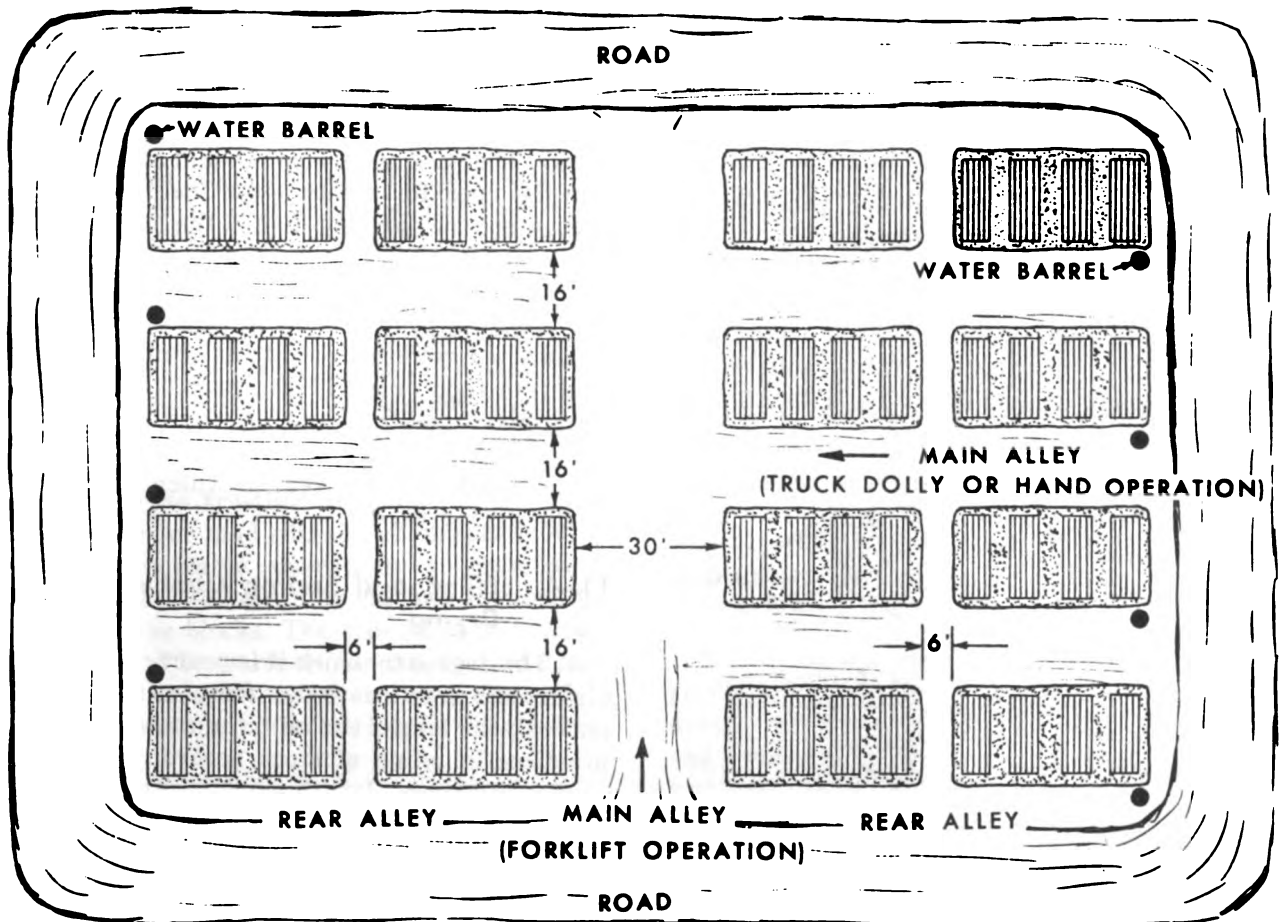

Figure 11-1. A lumberyard layout.

The yard should be easily accessible from the mill. It should be on ground which is suitable for hauling and for pile foundations and is open to air currents for lumber drying. Good air circulation and soil drainage and a level or slightly rolling surface are essential to meet these needs. Uneven or steeply sloping surfaces require excessive cribbing for pile foundations and grading for roads.

c. The ground should be kept free from debris and vegetation. Debris harbors fungi and insects and interferes with air movement. Vegetation restricts air movement over the ground surface and from beneath the lumber piles. When the vegetation becomes dry it creates a fire hazard. Vegetation can be kept in check by cutting, or can be killed with chemical weed killers.

d. A road or an 8-foot fire lane is constructed in a clear area, or a 30-foot lane in a timbered area, around the margin of the yard. It is kept cleared of vegetation as a check against fires. Where organized fire protection is not available, water barrels and buckets should be placed according to a planned pattern. For example, they may be placed at the beginning and end of every fourth row, with enough intermediate barrels and buckets to keep the maximum travel distance to any one barrel at 75 feet. Adding 3-2/5 pounds of calcium chloride per gallon will prevent freezing of water at temperatures down to - 20° F.

e. In general, yard layout should provide for wide alleys and ample space between piles to insure good air circulation and adequate room for handling and hauling lumber. The layout should provide a clear space of 30 feet from temporary milling operations and 50 feet from semipermanent installations. Main alleys should be 16 feet

wide for motor truck or dolly hauling and hand stacking, or 30 feet wide for forklift truck hauling and piling. Forklift trucks move lumber with its greatest dimension at right angles to the direction of travel. The spacing between main alleys for hand-stacked piles is twice the length of a pile plus a rear alley of approximately 6 feet, a total of about 38 feet. With unit-package piles, stacked by forklift truck, the space between main alleys is optional, depending on the number and width of the piles in the rows and the space between them. Cross alleys should be 16 feet wide for motor truck or dolly hauling, or 30 feet wide for forklift truck hauling, and spaced about 100 feet apart to give ready access to main alleys.

f. For hand stacking, it is suggested that the piles be 6 feet wide and about 10 feet high, with a space of about 2-1/2 feet between the piles. Unit packages for yard drying are generally about 4 feet wide, and are stacked three to five units high. A space of about 2 feet should be left between the piles of unit packages in a row, and 3 to 4 feet between rows.

11-3. Lumber Props

The use of lumber props (fig 11-2) in loading trucks is a quick and efficient aid. The props work on the same principle as the log preloaders (fig 7-19). The yard supervisor should always emphasize the need for safety when loading props are used, since they are apt to spill the load if mishandled or bumped by the lumber truck. As the lumber comes from the mill it is placed on the props, one size to a prop. The prop is just high enough so that the vehicle's rear bunk contacts the load about an inch ahead of the prop, the prop itself being about one-third the length of the load from the high or loading end. The load is then easily manhandled onto the vehicle which transports it to the drying yard.

11-4. Piling and Sorting Lumber for Air Drying

a. The degree to which it is practical to improve air-drying practice varies from mill to mill. In general, the larger the mill, the more exacting its practices in piling of stock according to species, grade, thickness, length, and width. Permanent mills can also do more in improving drainage, grading, and pile foundations.

b. The total number of piles necessary for a given operation depends upon production rates and seasoning time allowed, as well as demand.

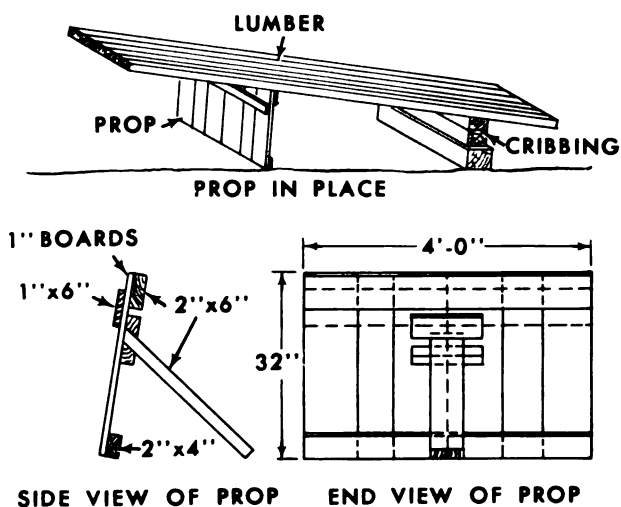

Figure 11-2. Lumber props.

The total number of piles open, or in the process of building, at one time depends mainly on how closely the lumber is segregated according to species, size, and grade. Inventory and shipping are benefited by putting each item that has a different demand rating into a separate pile. This, however, exposes more lumber to the weather, which may reduce its grade.

c. Each yard operator must determine the degree of segregation needed. Different thicknesses are, in general, piled separately. Hardwoods of different lengths and widths are usually placed in the same pile and may be separated according to grade. A common practice at small hardwood mills is to pile No. 1 common and better separately from No. 2 common and poorer.

d. Labeling of piles as to contents helps in identification and inventories. It can be done by surfacing (similar to blazing a tree) the edge of a sticker (flat piece or strip used to separate layers or courses) with a knife and writing with a soft crayon the pile number, species, item (width, thickness, and grade), piling data, and footage. The footage is an estimate made either when the pile is completed or at the first inventory afterwards.

11-5. Pile Foundations

a. The foundations should be mechanically strong, and sufficient to raise the first course of lumber at least 18 inches from the ground. Piers, posts, or blocks are a more satisfactory support than cribbing because the foundation is more open for air movement beneath the pile. For permanent yards, piers of concrete or masonry, or posts that are of a decay-resistant species or pressure-treated with a preservative, make excellent supports. Piers or posts set into firm ground should extend below the frostline. Posts or blocks may rest on sleepers or mud sills placed on soft ground surface. At portable operations a reasonably sound log of low value can be cut into sections to provide posts or blocks. The tops of each pair of supports should be surfaced or cut so that they are on a level crosswise, and are on a slope of 1 inch to the foot or on a level in a lengthwise direction.

b. The rest of the foundation consists of stringers and crossbeams, or of crossbeams only. Stringers, generally 6 to 8 inches in dimension, laid on edge, are placed on tops of the piers, posts, or blocks. The stringers run lengthwise and follow the slope. Crossbeams, generally 4 by 4 or 4 by 6

inches in dimension, are laid on the stringers, or on the top of the piers, posts, or blocks where stringers are absent. Where stringers are used, the number of piers, posts, or blocks can be reduced. Stringers also permit more flexibility in the positioning of the crossbeams so that with piles of different lengths, the crossbeams can be placed to support the vertical tiers of stickers.

c. Foundations for unit-package piles are usually level in both directions. Stringers cannot be used except where the rows of piles consist of two piles only. A satisfactory foundation for unit-package piles consists of cross-beams 4 feet apart supported by piers, posts, or blocks. A central 8-foot space is left clear for the entrance and exit of the forklift truck by omitting the central crossbeam. A removable and replaceable device carrying a crossbeam or its equivalent should be used to support the center of the pile. This support is put in place when the particular pile is made, but is removed to allow the forklift truck to approach piles nearer the center of the row. Such a support may be a sawhorse or a crossbeam with legs.

11-6. Pile Construction

a. For air drying, it is almost universal practice to pile stock flat, so that most of the weight bears on the wide faces, not on the edges or ends. A flat pile may be level both crosswise and lengthwise. With this method of piling the drying rate is relatively slow, but the weight of the pile tends to keep the stock from warping. It is therefore suited to species that are likely to suffer from sap stain. Flat piles may be hand-stacked in a continuous pile from bottom to top or may be made up of several unit packages separated by bolsters. Hand-stacked piles may be square at both ends, such as a box of sorted length pile, or the board ends may project or overhang at the rear or at both ends. To prevent excessive warp, it is desirable either to sort for length or to box pile so as to eliminate overhanging ends.

b. For lumber that is susceptible to sap stain, special piling methods that promote rapid partial drying are sometimes used. These are known as end piling (1, fig 11-3), end racking (2, fig 11-3), and crib piling (3, fig 11-3).

c. To obtain rapid drying with end piling, wide spaces should be left between boards. End piling (1, fig 11-3), described in paragraph 11-12, though easily done by one man, causes nonuniform drying from top to bottom, and severe end

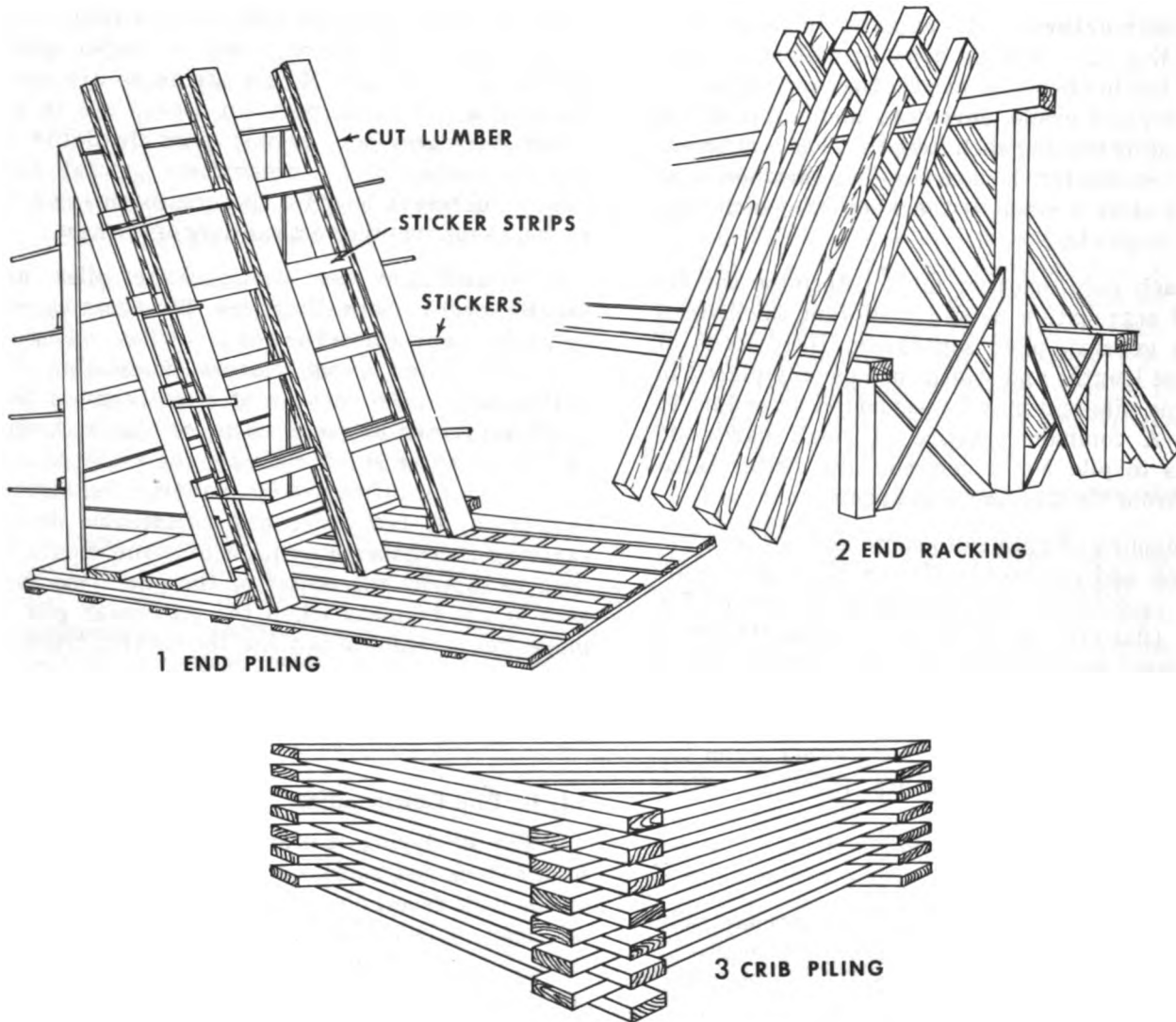

Figure 11-3. End, rack, and crib piling methods.

checking and surface checking in the upper parts of the boards, particularly in thick stock. End racking (2, fig 11-3), described in paragraph 11-13, causes rapid drying, but also excessive checking and warping. Once the stock has become dry enough to prevent the fungus-caused discoloration known as blue stain, it should be piled flat to minimize checking and warping. This will be in from 30 to 45 days in most cases, depending on the temperature and weather. End-racked boards, however, are likely to blue stain where they cross. Crib piling (3, fig 11-3), described in paragraph 11-14, also promotes fast drying, but may result in excessive stain where the boards cross, as well as warping.

11-7. Box Piling

Box piling is recommended for hardwoods. To make a box pile (1, fig 11-4), lay a sticker over

each foundation crossbeam and place a full-length board in each of the outside tiers. If enough stock is available for more than two full-length boards to the course, place long boards regularly in the course (2, fig 11-4). Place shorter boards in the inside tiers, with their ends alternately flush with the front and back of the pile. Each tier is approximately 12 inches wide; thus it can contain an 8- and a 4-inch board, or two 6-inch boards. One end of each board can rest on the sticker at either end of the pile. Tiers should be truly vertical, 4 to 6 inches apart. The front of the pile should be given a pitch of 1 inch per foot of height. This method of piling results in vertical flues that allow a free downward air flow from the top to the bottom of the pile. Both ends of the pile should be square with no projecting board ends.

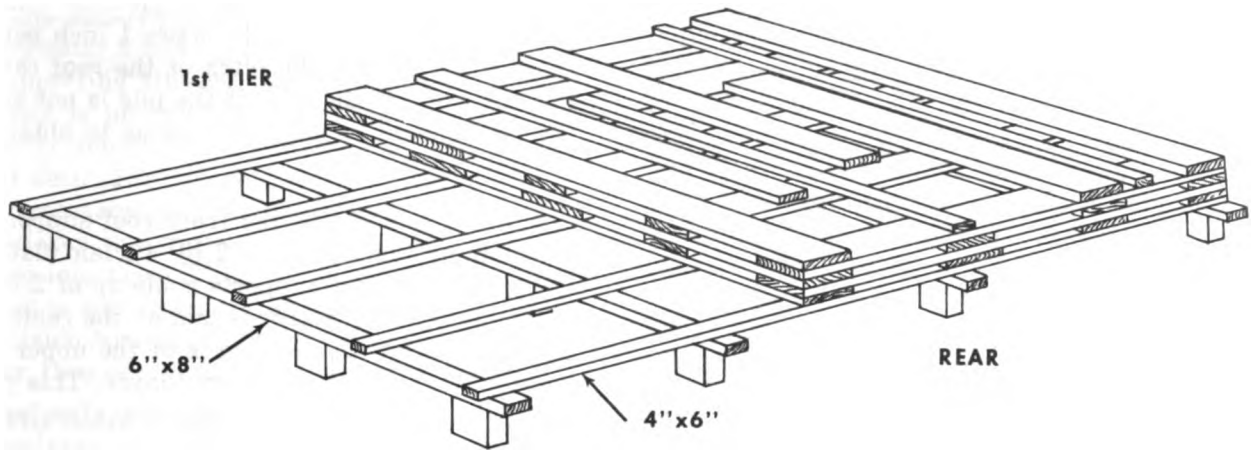

1

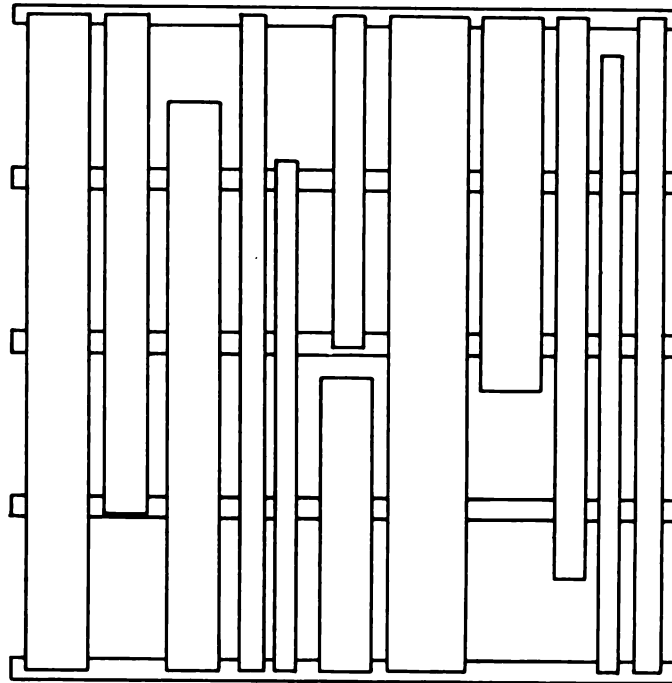

2

- 1 Method of laying on foundation
- 2 Top view showing board placement according to length

Figure 11-4. Box piling.

11-8. Sorted-Length Piling

a. Sorted-length piling, which closely resembles box piling, is recommended for softwoods. To make such a pile, lay a sticker over each cross-beam and place the first course of boards so that the front end of each board is flush with the front edges of these stickers. Space the boards in this course 2 to 3 inches apart; if two or more lengths

are included in the same pile, place the longest ones in the outside tiers, and mix other long ones regularly in the course to give a well supported pile. Succeeding courses duplicate the first or base course.

b. The front of the pile should pitch toward the main alley, 1 inch to a foot of height. Each tier of stickers within a tier should be alined parallel to

the front one. Stickers within a tier should be directly above one another except for the slight progressive offset required to follow the pitch of the pile. The front of the pile should be free of projecting ends that would catch water and cause it to flow into the pile. If the boards are of uniform lengths and the piling has been well done, the rear of the pile will also be free of projecting ends.

11-9. Unit-Package Piling

Unit-package piles are composed of from three to five unit packages, placed by forklift truck. The unit packages are made up at the rear of the mill, using methods similar to those recommended for flat piling. They are hauled to the yard by forklift truck and built into piles. Good sticker alinement and uniform spacing are essential in unit packages of lumber in order to obtain good alinement of crossbeams, bolsters, and tiers of stickers in the yard pile of unit packages. Piles of unit packages do not ordinarily have either slope or pitch.

11-10. Stickers

Stickers are used to separate the courses of lumber in a pile. Stock stickers are narrow boards of the same lumber as the pile. Such piles are commonly called self-stickered. Self-stickering may be justified with a low-value lumber, where degrade suffered through staining and checking is not important. Special stickers for lumber up to 3/8-inch thickness are generally made of nominal 1-inch stock, rough or dressed. Stickers for thicker lumber may be about 1-1/2 inches thick. Special stickers for hardwoods are generally about 1 inch thick by 1-1/2 to 2 inches wide, and for softwoods 1 by 2 or more inches. Special stickers should preferably be of air-dried heartwood. At small portable mills, edgings that have been air-dried provide relatively cheap and satisfactory stickers. Stickering of unit packages of lumber follows the same rules as stickering of hand-stacked piles, except that the narrow width of the packages rules out the use of stock for stickers.

11-11. Pile Roofs

a. If yard piles are not roofed, the upper courses of lumber are likely to deteriorate enough to cause a drop in grade. The roof should protect the pile from sunshine and precipitation and should be reasonably tight. A common type of pile roof is one composed of a double layer of low grade boards. The roof should be pitched so that

most of the water will run to the rear end and drip off. If the lumber pile slopes 1 inch per foot from front to rear, the pitch of the roof can follow the slope of the pile. If the pile is not sloped, the roof should be supported so as to obtain the required pitch.

b. For a sloped pile, the front roof support can be made by placing three 2 by 4's laid flat with the center and rear supports made up of 2 by 4's. A double layer of boards is laid on the center and rear supports with the boards of the upper layer overlapping those in the lower layer. This procedure is repeated for the front part, allowing this part of the roof to overlap the rear portion. The roof should project beyond the pile about 1 foot at the front and 2-1/2 feet at the rear. In windy regions, tie pieces wired to the pile should be placed at the front, center, and rear to keep the roof boards from blowing off.

11-12. End Piling

a. Lumber piled on end is equivalent to an upended flat pile. Boards for end piling (1, fig 11-3) should be grouped according to length. With random-width stock, like widths should be placed in the same row or upended tier. In its simplest form, end piling requires a floor, a central rack, and strips or some other device to support the stickers. End piling should be used as local circumstances dictate (para 11-6).

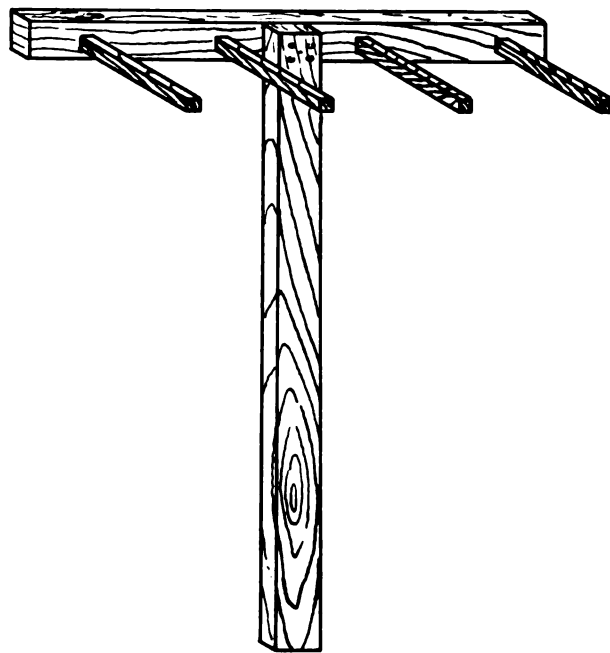

Figure 11-5. Sticker holder.

b. The stickers must be placed and held until the two outer boards of a course are placed. Strips for supporting stickers can be dispensed with if the piler is provided with a sticker holder (fig 11-5). It consists of a handle that reaches the height desired for placing the sticker and one or more crossarms each approximately 3 feet long. The sticker that rests on the crossarm is easily boosted into place. Then, while the handle end of the tool is supported on the base, the piler places the outside boards of the next course against the sticker, thus permitting removal of the holder.

c. The floors should be of latticed construction and should support the lumber at least a foot above the ground. The central rack should be sturdy. Piles are generally built up in two directions from the rack, but occasionally in only one direction. The piles are usually about 10 feet wide and 75 to 100 feet long, with an 8-inch space between the rows of boards.

11-13. End Racking

a. In end racking, two rows of boards placed end are crossed like an X or preferably form an inverted V (fig 11-3). The boards are supported by a ridge pole, and the lower ends should be supported about a foot above the ground. Since the boards will cross at their top ends in order to support each other in an upright position, different racks will be needed for different length stock.

b. The stock dries rapidly; 30 to 45 days of drying, depending on the weather, usually is sufficient to prevent staining. After this period the lumber should be flat-piled or shipped to prevent excessive checking and warping in the end-racked pile. End-racking should be used as local circumstances dictate (para 11-6).

11-14. Crib Piling

Crib piling, used by some small mills cutting southern pine, eliminates foundations, stickers, and pile roofs but requires excessive yard space. Separate piles are made for each length by cribbing three tiers in the form of a triangle (3, fig 11-3). The first plank rests on supports at each end. One end of the second plank crosses the first above a support and the other end rests upon the third support of the triangle. The third plank closes the triangle. In succeeding courses this crib rack is carried to a height convenient for one-man stacking. The drying rate is like that of end-racked lumber. If excessive checking and warping are to be avoided, the cribbed lumber should be

taken down and flat-piled after 3 to 15 days. Crib piling should be used as local circumstances dictate (para 11-6).

11-15. Refinements in Flat-Piling Practice

a. In flat piles, the drying rate and consequent degrade by blue stain, decay, checking, and warping are likely to vary with the location of the pile, the species of wood, and the season. Therefore, where there is need to reduce such undesirable effects, the following refinements in piling may be considered.

b. To reduce checking—

(1) Lower the foundations; decrease the spacing between boards and between piles.

(2) Use thinner, narrow stickers. Place end stickers so that they project beyond end of pile.

(3) Use end coatings.

(4) Shield from sun and wind by piling in abandoned buildings where available.

c. To reduce blue stain and decay occurring throughout the pile—

(1) Raise the foundations; increase the spacing between boards and between piles.

(2) Provide one central flared chimney or a series of narrow chimneys. Chimneys are formed by leaving boards out of each course in such a way that a vertical opening is left from the top to the bottom of the pile.

(3) Narrow the piles.

11-16. Safety in Yard Operations

a. Personnel handling rough-sawn lumber should always wear heavy leather gloves to protect their hands against splinters.

b. Lumber should not be stacked without a proper foundation.

c. Lumber stacked too high is hazardous in that it is easily blown or pushed over.

d. Smoking should not be allowed in the lumberyard.

e. First aid and firefighting equipment should always be available for use by any personnel working in the lumberyard.

f. Personnel should be prohibited from riding as passengers on materials handling equipment.

g. All trash and vegetation should be cleared away from lumber stacks.

h. Trucks moving in and out of the lumberyard should not go faster than 5 miles per hour.

i. Indigenous personnel employed in the lumberyard should be instructed in good safety practices.

APPENDIX A
REFERENCES

A-1. Army Regulations (AR)

- 310-31 Management System for Tables of Organization and Equipment (The TOE System).
- 310-34 Equipment Authorization Policies and Criteria, and Common Tables of Allowances.

(FM)

Engineer Troop Organizations and Operations
First Aid for Soldiers

Manuals (TM)

- ✓ 6040
Planning and Design of Roads, Airfields, and Heliports in the Theater of Operations
- Rigging
- Air Transport of Supplies and Equipment:
External-Transport Procedures
- Air Transport of Supplies and Equipment:
Helicopter External Loads Rigged with Air Delivery Equipment
- Air Transport of Supplies and Equipment:
Helicopter External Loads for Sling, Nylon and Chain, Multiple Leg (15,000-Pound Capacity) FSN 1670-902-3080
- Military Handbook: Lumber and Allied Products

Tables of Organization and Equipment (TOE)

Engineer Equipment Operating Teams

Use of Computers in Labour Administration.
(1989) 195 p.

 ILO
6/C73

APPENDIX B

METRIC SYSTEM

Section I. GRAPHIC COMPARISON OF THE LINEAR ENGLISH AND THE METRIC SYSTEM

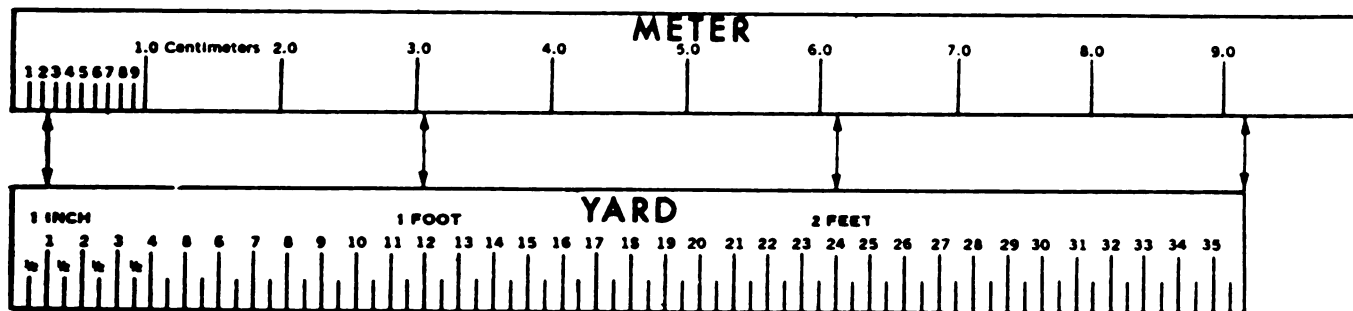

Figure B-1. Comparison of the linear English and metric systems.

Section II. CONVERSION TABLES

METRIC into ENGLISH EQUIVALENT

- 1 millimeter = 0.04 inch
- 1 centimeter = 0.39 inch
- 1 meter = 39.37 inches
= 1.09 yards
- 1 kilometer = 0.62 statute mile

- 1 square centimeter = 0.1550 square inch
- 1 square meter = 10.7639 square feet
- 1 square meter = 1.1959 square yards
- 1 hectare = 2.471 acres
- 1 hectare = 0.0039 square miles

- 1 cubic centimeter = 0.27 fluid dram
- 1 liter = 1.06 liquid quarts

ENGLISH into METRIC EQUIVALENT

Linear Measure

- 1 inch..... 2.54 centimeters
- 1 foot..... 0.3048 meter
- 1 yard..... 0.9144 meter
- 1 mile..... 1.6093 kilometers

Area

- 1 square inch..... 6.4516 square centimeters
- 1 square foot..... 0.0929 square meter
- 1 square yard..... 0.8381 square meter
- 1 acre..... 0.4047 hectare
- 1 square mile..... 2,590 square kilometers

Capacity or Volume

- 1 cubic inch..... 16.3872 cubic centimeters
- 1 cubic foot..... 0.0283 cubic meter
- 1 cubic yard..... 0.7646 cubic meter
- 1 fluid ounce..... 29.5735 milliliters
- 1 pint..... 0.4732 liter
- 1 quart..... 0.9463 liter
- 1 gallon..... 3.7853 liters

METRIC into ENGLISH EQUIVALENT

ENGLISH into METRIC EQUIVALENT

Mass or Weight

1 gram = 0.04 ounce (avdp)
 1 kilogram = 2.20 pounds (avdp)
 1 metric ton = 1000 kilograms
 = 2204.62 pounds (avdp)
 = 1.10 tons

1 ounce 28.3495 grams
 1 pound (avdp) 0.4536 kilogram
 1 hundredweight (cwt) .. 45.3592 kilograms

Temperature

	Fahrenheit	Centigrade (Celsius)	Absolute (Kelvin)
Boiling p			
Boiling point of water	212°	100°	373.15°
Freezing point of water	32°	0°	273.15°
Absolute zero	-459.67°	.273.15°	0°
Body temperature	98.6°	37°	310.15°

Prefix

Meaning

mega- 1,000,000 or 10^6 , times the basic unit
 kilo- 1,000, or 10^3 , times the basic unit
 hecto- 100, or 10^2 , times the basic unit
 deca- 10, or 10^1 , times the basic unit
 deci- $\frac{1}{10}$, or 10^{-1} , times the basic unit
 centi- $\frac{1}{100}$, or 10^{-2} , times the basic unit
 milli- $\frac{1}{1000}$, or 10^{-3} , times the basic unit
 micro- $\frac{1}{1,000,000}$, or 10^{-6} times the basic unit

1 megameter is 1,000,000 meters.
 1 kilometer is 1,000 meters.
 1 hectometer is 100 meters.
 1 decameter is 10 meters.
 1 decimeter is $\frac{1}{10}$ meter.
 1 centimeter is $\frac{1}{100}$ meter.
 1 millimeter is $\frac{1}{1000}$ meter.
 1 micron is $\frac{1}{1,000,000}$ meter.

Section III. CONVERSION FACTORS

<i>Multiply</i>	<i>by</i>	<i>to obtain</i>
Acres	43,560	square feet
Acres	4,047	square meters
Acres	1.562×10^{-3}	square miles
Acres	5645.38	square varas
Acres	4,840	square yards
Acre-feet	43,560	cubic feet
Areas	0.02471	acres
Areas	100	square meters
Board-feet	144 sq in. x 1 in.	cubic inches
Centares	1	square meters
Centimeters	0.3937	inches
Centimeters	0.01	meters
Centimeters	393.7	mils
Centimeters	10	millimeters
Circular mils	5.067×10^{-6}	square centimeters
Circular mils	7.854×10^{-7}	square inches
Circular mils	0.7854	square mils
Cord-feet	4 ft x 4 ft x 1 ft	cubic feet
Cords	4 ft x 4 ft x 8 ft	cubic feet
Cubic centimeters	5.531×10^{-5}	cubic feet
Cubic centimeters	6.102×10^{-2}	cubic inches
Cubic centimeters	10^{-6}	cubic meters
Cubic centimeters	1.308×10^{-6}	cubic yards
Cubic feet	2.832×10^4	cubic centimeters
Cubic feet	1,728	cubic inches
Cubic feet	0.02832	cubic meters
Cubic feet	0.03704	cubic yards
Cubic inches	16.39	cubic centimeters
Cubic inches	5.787×10^{-4}	cubic feet
Cubic inches	1.639×10^{-5}	cubic meters
Cubic inches	2.143×10^{-5}	cubic yards
Cubic meters	10^6	cubic centimeters
Cubic meters	35.31	cubic feet
Cubic meters	61,023	cubic inches
Cubic meters	1.308	cubic yards
Cubic yards	7.646×10^5	cubic centimeters
Cubic yards	27	cubic feet
Cubic yards	46,656	cubic inches
Cubic yards	0.7646	cubic meters
Decimeters	0.1	meters
Degrees (angle)	60	minutes
Degrees (angle)	0.01745	radians
Dekameters	10	meters
Feet	30.48	centimeters
Feet	12	inches
Feet	0.3048	meters
Feet	.36	varas
Feet	1/3	yards
Hectares	2.471	acres
Hectares	1.076×10^5	square feet
Hectometers	100	meters
Inches	2.540	centimeters
Inches	10^3	mils
Inches	.03	varas
Kilometers	10^5	centimeters
Kilometers	3281	feet
Kilometers	10^3	meters
Kilometers	0.6214	miles
Kilometers	1093.6	yards
Links (engineer's)	12	inches
Links (surveyor's)	7.92	inches

<i>Multiply</i>	<i>by</i>	<i>to obtain</i>
Meters	100	centimeters
Meters	3.2808	feet
Meters	39.37	inches
Meters	10^{-3}	kilometers
Meters	10^3	millimeters
Meters	1.0936	yards
Miles	1.609×10^5	centimeters
Miles	5,280	feet
Miles	1,6093	kilometers
Miles	1,760	yards
Miles	1900.8	varas
Millimeters	0.1	centimeters
Millimeters	0.03937	inches
Millimeters	39.37	mils
Mils	0.002540	centimeters
Mils	10^{-4}	inches
Quadrants (angle)	90	degrees
Quadrants (angle)	5,400	minutes
Quadrants (angle)	1.571	radians
Radians	57.30	degrees
Radians	3,438	minutes
Radians	0.637	quadrants
Radians per second	57.30	degrees per second
Rods	16.5	feet
Square centimeters	1.973×10^5	circular mils
Square centimeters	1.076×10^{-3}	square feet
Square centimeters	0.1550	square inches
Square centimeters	10^{-6}	square meters
Square centimeters	100	square millimeters
Sq cm-cm sqd	0.02402	sq inches, inches sqd
Square feet	2.296×10^{-5}	acres
Square feet	929.0	square centimeters
Square feet	144	square inches
Square feet	0.00929	square meters
Square feet	3.587×10^{-8}	square miles
Square feet	.1296	square varas
Square feet	1/9	square yards
Sq feet-feet sqd	2.074×10^4	sq inches-inches sqd
Square inches	1.273×10^6	circular mils
Square inches	6.452	square centimeters
Square inches	6.944×10^{-8}	square feet
Square inches	10^{-6}	square mils
Square inches	645.2	square millimeters
Sq inches-inches sqd	41.62	sq cm-cm sqd
Sq inches-inches sqd	4.823×10^{-5}	sq feet-feet sqd
Square kilometers	247.1	acres
Square kilometers	10.76×10^6	square feet
Square kilometers	10^6	square meters
Square kilometers	0.3861	square miles
Square kilometers	1.196×10^6	square yards
Square meters	2.471×10^{-4}	acres
Square meters	10.764	square feet
Square meters	3.861×10^{-7}	square miles
Square meters	1.196	square yards
Square miles	640	acres
Square miles	27.88×10^6	square feet
Square miles	2.590	square kilometers
Square miles	3,613,040.45	square varas
Square miles	3.098×10^6	square yards
Square millimeters	1.973×10^3	circular mils
Square millimeters	0.01	square centimeter
Square millimeters	1.550×10^{-3}	square inches
Square mils	1.273	circular mils
Square mils	6.452×10^{-6}	square centimeters
Square mils	10^{-6}	square inches

<i>Multiply</i>	<i>by</i>	<i>to obtain</i>
Square varas	.0001771	acres
Square varas	7.716049	square feet
Square varas	.0000002765	square miles
Square varas	.857339	square yards
Square yards	2.066×10^{-4}	acres
Square yards	9	square feet
Square yards	0.8361	square meters
Square yards	3.228×10^{-7}	square miles
Square yards	1.1664	square varas
Varas	2.777	feet
Varas	33.3333	inches
Varas	.000526	miles
Varas	.9259	yards
Yards	91.44	centimeters
Yards	3	feet
Yards	36	inches
Yards	0.9144	meters
Yards	1.08	varas

GLOSSARY

- Aerial logging**—A yarding system employing aerial means such as balloons or helicopters.
- Air drying**—The practice of seasoning lumber in the open air as contrasted with seasoning it in a kiln.
- Anchor cable**—A short line used to tie down a yarder to prevent tipping.
- Anchor log**—A wooden, concrete, or metal bar used as a deadman.
- Anvil (swage)**—The fixed jaw in a swaging device that supports the back of the tooth while the die or roller presses against the front of the tooth.
- Arbor**—The shaft and bearings on which a circular saw is mounted.
- Arch**—Machine to be towed behind a tractor having crawler type wheels; logs are suspended in the arch for removal to the sawmill or landing. The arch may have either crawler type wheels or conventional wheels—often mounting pneumatic tires.
- Back**—Upper or top part of a saw tooth.
- Back guy**—The line back of the spar tree, opposite the lead of the main line or skyline.
- Backing board**—In sawing lumber on a headsaw, the last board in the log, to which the carriage dogs are attached.
- Back rest**—A wood bench opposite the tensioner, used to support a circular saw when checking tension.
- Band mill**—1. Sawmill equipped with band headsaw. 2. Machine on which bandsaws are mounted.
- Bandsaw**—Endless, beltlike blade of steel, toothed on one or both edges, used to saw lumber.
- Barb**—A sharp projection, the point of which is at right angles to the fastener proper, that is, the shaft of the fastener.
- Bearings**—A part in which the journal, gudgeon, pivot, pin, or the like, turns or revolves.
- Bed piece**—Timber or similar flattened piece laid on the ground to support a load, such as lumber piles, sawmill parts, etc.
- Bevel**—Sloping part of a surface.
- Bit**—1. Tooth used in an inserted-tooth saw. Synonym: inserted tooth, point. 2. Knives used on the cutter heads of surfacing machines to cut a tongue and a groove.
- Blaze**—A mark made on the trunk of a standing tree by chipping off a spot of bark with an ax. It is used to indicate a trail, a boundary, location for a road, trees to be cut, and so on.
- Block**—A wooden metal case enclosing one or more pulleys.
- Block setter**—One who operates the setwork on a sawmill carriage. Synonym: ratchet setter, setter.
- Blue stain**—(Blued lumber)—A bluish or grayish discoloration of sapwood caused by the growth of certain moldlike fungi on the surface and in the interior of the piece; made possible by the same conditions that favor the growth of other fungi. This is normally not harmful to structural or finishing properties except in appearance.
- Board**—See Lumber.
- Board dog**—See Carriage dog.
- Board foot**—Unit of measure in lumber trade. Board foot is section 12 by 12 inches in size and 1 inch thick, or its equivalent. Abbr = bd ft.
- Board measure**—Measurement in board feet. Abbr = Bm.
- Board mill**—A sawmill that makes a specialty of 1- and 2-inch lumber as compared to a mill that makes a specialty of material of greater thickness.
- Bole**—Trunk of a tree.
- Bolster**—A structural part intended to afford support for logs on a sawmill carriage.
- Boss dog**—A dogging device on the knees of a sawmill carriage consisting of lever-controlled talons which can be brought to grip the face of a log, cant, or timber.
- Boxed heart**—The term used when the sawmill, in sawing timbers, cuts boards from all sides of heart, leaving center as piece of timber.
- Box lumber**—Lumber from which boxes are manufactured.
- Box piling**—A method used in piling lumber for drying by which boards of differing widths and lengths make up a course.
- Break down**—1. To reduce large logs to size which

- can be sawed on main log saws in sawmill. 2. To cut logs into cants.
- Breakdown*—To stop mill or machine because machine is out of order.
- Bright sap*—Sap which is not stained.
- Bucking*—Sawing felled trees into logs.
- Buckle guy*—A line attached to the middle of a spar tree.
- Buggy*—See Lumber buggy; Trolley.
- Bulk pile*—To pile closely, without cross strips.
- Bullblock*—The main line lead block in high-lead yarding.
- Bummer*—A low, two-wheeled truck for skidding logs.
- Bumper*—In sawmill, device placed at each end of carriage run to absorb shock of carriage when it has traveled to extreme end of track.
- Bunk*—The crossbeam on a log car or sled, truck, or trailer, upon which the logs rest.
- Burl*—A large, wartlike excrescence growing on a tree trunk. It contains the dark piths of a large number of buds which rarely develop. The formation of a burl apparently results from an injury to the tree.
- Burner*—An open or inclosed structure in which slabs, sawdust, bark, and other sawmill wood refuse are burned.
- Butt*—Base of a tree, or big end of a log.
- Butt cut*—First log above the stump. Synonym: butt log.
- Butt hook*—The heavy hook on the butt rigging to which chokers are attached.
- Cable logging*—A yarding system employing winches in a fixed position.
- Cableway*—A transporting system typically consisting of a cable suspended between elevated supports so as to constitute a track along which carriers can be pulled.
- Canker*—A pronounced, local distortion of the stem due to injury or disease, in advanced stages evidence of serious heart rot.
- Cant*—A log that has been slabbed on one or more sides.
- Cant a log*—To remove slabs from one or more sides of a log.
- Cant hook*—A tool like a peavy, but having a toe ring and lip at the end instead of a spike. See Peavy.
- Carriage*—A frame on which are mounted the headblocks, setworks, and other mechanisms for holding a log while it is being sawed, and also for advancing the log toward the saw line after a cut has been made. The carriage frame is mounted on trucks which travel on tracks, the carriage being actuated by a steam feed, a cable, or a rack-and-pinion device, which propels it back and forth past the head saw.
- Carriage dog*—Steel toothlike projection, several of which are attached to carriage knee and operated by lever. Carriage dogs are used to hold the log firmly on the carriage. Synonym: board dog, dog.
- Carriage feed*—Device used to drive sawmill carriage back and forth. It may consist of rack-and-pinion, cable and sheaves, or large steam cylinder equipped with piston which actuates carriage. In large mills steam cylinder is used for short carriages and cable for long carriages. In portable mills rack-and-pinion or cable feed is used.
- Carriage rider*—See Dogger.
- Check*—A lengthwise separation of the wood, the greater part of which occurs across the rings of annual growth.
- Checker*—One who counts the number of pieces of lumber as they are loaded on a vessel or into a car.
- Chimney*—Opening left from top to bottom of lumber pile to facilitate circulation of air and to hasten seasoning.
- Chip*—The shaving or segment taken by a single sawtooth.
- Chipping headrig*—A mechanism used for further conversion of small logs into cants. It produces chips instead of sawdust and slabs.
- Choker*—A noose of wire rope for hauling a log.
- Choker hook*—The fastener on the end of a choker that forms the noose.
- Circular headsaw*—A circular plate having cutting teeth on the circumference and used to rip-saw logs.
- Cleanup man*—One who cleans up refuse in a sawmill or planing mill.
- Clearance angle*—The angle between a tangent to the cutting circle of a tooth and a line along the top of the tooth intersecting this tangent.
- Clear face*—1. In cutting hardwoods, board surface area free from defects recognized in grading hardwood lumber. 2. In a log, quadrant of log surface without blemishes indicative of causing defects in lumber.
- Clear lumber*—Lumber practically free from all defects.
- Climbing rope*—A manila rope anchored to the belt of a high rigger who is looped around the tree to provide a brace.
- Closing line*—A line used to close a grapple.
- Coarse grained*—As applied to grain of lumber, that which has wide annual rings.

- Cold deck**—A pile of logs left for later transportation.
- Collar**—A ring or round flange upon, surrounding, or against an object and used chiefly to restrain motion within given limits, to hold something in place, or to cover an opening.
- Conical roller bearings**—Roller bearings with tapered rollers.
- Conk**—The fruiting body of a rot-producing fungus contained in the tree.
- Conveyor chain**—An endless chain used for carrying material place to place.
- Corner block**—A block used to guide the haulback line at the back corner of the yarding area.
- Course**—A single layer of boards in a pile of lumber.
- Crane**—A machine that lifts and moves heavy weights by means of a movable projecting arm.
- Crib piling**—Piling lumber to form a triangular pen with the end of a board overlapping the end of the board below. Usually each side is a single tier.
- Crook**—See Sweep.
- Cross alleys**—Alleys in the lumberyard at right angles to main alleys to facilitate lumber movement and air flow.
- Crosscut**—To cut board or timber at right angles to general direction of fibers.
- Cross grain**—As applied to the grain of lumber, a piece in which wood elements interweave and are not constant in any one direction. Synonym: spiral grain.
- Cross support**—A lateral line used to provide intermediate support for a multispan skyline.
- Cruise**—To inspect forest land in order to estimate its yield of lumber.
- Cruiser**—A timber estimator.
- Cruiser's stick**—Instrument used for measuring timber.
- Cull**—See Grade.
- Custom sawing**—The sawing of lumber under contract, usually to given specifications.
- Cut**—Output of sawmill for given period of time. Synonym: running.
- Cutoff man**—One who operates cutoff saw in sawmill.
- Cutoff saw**—Circular saw or bandsaw used in sawmill or other wood-working establishment to crosscut logs, timbers, and boards. Synonym: butt saw, butting saw.
- Cutting**—An estimate of the amount of lumber that will be cut by a pass through the saw.
- Cutting face**—That part of a sawtooth which extends from the point or edge down toward the gullet, a distance equal to that where cutting or shearing of fibers is done.
- Cutting unit**—An area of timber designated for cutting.
- Deadman**—See Anchor log.
- Dead rollers**—Rollers used for the handling of lumber, but not power driven.
- Decay**—Disintegration of wood substance through the action of wood-destroying fungi.
- Deck**—The platform in a sawmill on which logs are collected and stored before they are placed on the carriage for sawing.
- Deck man**—In a sawmill, one who alines logs on the deck and rolls them down for loading on the carriage.
- Deck scaler**—One who scales logs on deck of sawmill and also operates levers controlling log kicker.
- Deck skids**—Sets of timbers used to form a rollway for logs at the mill deck.
- Defect**—Any irregularity occurring in or on wood that may lower its strength.
- Degrade**—Characteristics of a board the presence of which causes the quality of the board to be lowered.
- Dial**—See Networks scale.
- DIB**—Diameter inside bark.
- Die**—(Swage)—One of a pair of shaping tools, which, when moved toward each other, produce a certain desired form in an object. In a swage tool the die is the movable part, the anvil the fixed part of the shaper.
- DOB**—Diameter outside bark.
- Dock**—An elevated structure at the rear of a sawmill on which sawed products are stored and from which they can be loaded on cars or ships by gravity.
- Dog**—See Carriage dog.
- Dog board**—See Backing board.
- Dogger**—One who rides on the sawmill carriage and handles the lever which operates dogs that hold the log. Dogger on the front end of the carriage is sometimes called head-end dogger, and the one on rear end, rear-end dogger.
- Dogging**—Process of fixing the dogs in the wood or releasing them from it.
- Dog housing**—The metal frame sheltering and supporting the dog.
- Dolly**—1. Roller set in square frame on which timbers are placed when they are to be moved by hand from one place to another. 2. See Lumber buggy.
- Dote**—General term used by lumbermen to denote decay or rot in timber.

- Doty**—Decay. Synonym: dozy.
- Double-acting setworks**—A device on the carriage of a sawmill which feeds the timber to be sawed transversely at both the thrust and return stroke of the activating lever.
- Double bed**—The metal member supporting the slab or flitch being sawn. It is divided into two parts each of which can be independently set at a desired distance from the saw.
- Double mill**—Sawmill having two headsaws.
- Double sheave**—A pulley block with two grooved wheels.
- Downgraded**—Placed in a lower grade.
- Drag**—A collection of logs choked and attached to a towing vehicle.
- Dressed lumber**—Lumber which has been dressed or surfaced on one or more sides.
- Dressed size**—The dimensions of lumber after shrinking from the green dimension and planing; usually $\frac{3}{8}$ inch less than the nominal or rough size; for example, a 2 by 4 stud actually measures $1\frac{5}{8}$ by $3\frac{5}{8}$ inches. See Lumber; Nominal size.
- Drive pulley**—The first of a train of pulleys, giving motion to the rest.
- Drum**—A revolving cylinder upon which the cable imparting motion to the carriage is wound or unwound.
- Dry mill**—Sawmill which has no log pond.
- Dummy tree**—A small tree that is rigged to help raise a spar tree.
- Dump log**—A mill platform on which logs are loaded from log cars. It may be built around the edge of a pond or along the bank of a stream to aid in dumping logs into water, or it may be built for use as a place for dry storage of logs.
- Dump ramp**—The platform and incline from which logs are unloaded.
- Dutchman**—A block arrangement used to pull a bight on a line.
- Dutch oven**—An extension front used with boilers burning sawdust and similar fuel. It provides greater fuel space and permits more complete combustion.
- Eccentric**—Not having a true center.
- Ecology**—Relations between living organisms and their environment.
- Edge**—To make square-edged.
- Edger**—A machine used in sawmills to square-edge waney lumber and to rip lumber. It consists of frame supporting arbor on which are mounted several circular saws, feed rolls, press rolls, and transmission gears.
- Edger man**—One who feeds boards into edger.
- Edger tables**—Tables with rollers which are placed both in front of and behind edger.
- Edger trailer**—One who removes strips and edgings from roller at rear of edger. Synonym: strip catcher, tail edger.
- Edgings**—Strips, usually discarded or burned as fuel, that are cut from the edges of boards.
- Encased knot**—A knot surrounded wholly or partially by pitch or bark.
- End-pile**—To pile lumber on end. A method sometimes employed in storage sheds, both at manufacturing plants and at retail yards.
- End rack**—Lumber edge-tilted against a ridgepole to form an inverted V.
- Eye (saw)**—The hole through the center of the saw which receives the shaft.
- Eye splice**—A loop formed by bending a rope's end back and splicing it into the line.
- Face**—Lower or front portion of saw tooth, adjacent to the cutting edge.
- Face(log)**—A quadrant of the surface of a log.
- Factor of safety**—The ratio of the ultimate strength of a line or piece of material to the actual working stress or the maximum permissible stress when in use.
- Factory and shop lumber**—Lumber intended to be cut up for use in further manufacture. It is graded on the basis of the percentage of the area which will produce a limited number of cuttings of a specified, or a given minimum, size and quality.
- Fairlead**—A device that consists of pulleys or rollers arranged to permit reeling in a cable from any direction.
- Fake knees**—See Taper bar.
- Fall block**—A long narrow block with the sheave at the top.
- Fan-shaped cutting unit**—A setting with roads radiating from a common landing.
- Fbm**—Foot board measure (measure in board feet).
- Featheredge**—Board which is thinner on one edge than it is on the other is said to have a feather edge.
- Feed**—In sawing lumber the length of log, expressed in inches, which is cut at each revolution of the saw.
- Feed rolls**—Live rollers with a smooth, corrugated, or rough surface, which are used to feed lumber into the edger, resaw, planer, or other machine. See Live rollers.
- Feed works**—The mechanism which moves the carriage past the saw.

- Ferrule**—A metal band or socket at the end of a wire rope.
- Filer**—One who files saws in a sawmill or other woodworking plant.
- Fine grain**—Wood is said to have fine grain when annual rings of growth are narrow.
- Finish**—Higher grades of lumber. Synonym: finishing, uppers.
- Firm red heart**—Firm heartwood which has reddish color due to decayed wood adjacent to it. It is the incipient stage of red rot. Synonym: red heart.
- Fixed-arm reach**—Distance from observer's eye to the crotch of thumb and forefinger.
- Fixed collar**—A collar firmly attached to the saw arbor, as distinguished from a loose collar, which is held to the arbor with a nut.
- Fixed post**—A bar or rod firmly fixed to the knee or log beam of a sawmill carriage, which supports all or part of the dog mechanism.
- Fixed-slope distance**—Distance from observer's eye to the base of a tree.
- Flat pile**—Lumber piled so that each piece rests on its wide face.
- Flexible coupling**—A coupling of jointed links placed in a shaft to allow slight misalignment between two connected shafts.
- Flitch**—A lengthwise strip from the outer part of a tree trunk.
- Floating block**—A block to hold down the log against conveyor chains, one end being pivoted above the conveyed logs by means of a shaft and the other free to float or move up and down in bearing on the top of the moving log.
- Flooring**—Patterned lumber used for floors.
- Footage**—Quantity of lumber expressed in board feet.
- Friction wheel**—A wheel or disk driving, or driven by direct contact with, another wheel or disk.
- Gage**—A standard series of sizes indicating by numbers the thickness to which saws are made. The particular series of sizes adopted by saw manufacturers in the Birmingham and Stubbs wire gage.
- Gang circular**—A machine having a battery of circular saws, from 22 to 26 inches in diameter, all of which are fitted to the same shaft.
- Gate**—The frame in which gang saws and sash saws are stretched. The frame moves up and down in vertical grooves or slides, and is actuated by a pitman (connecting rod) attached to its base.
- Gig**—The act of running the sawmill carriage back after a board is cut from the log.
- Gondola**—An enclosure suspended from a balloon or cableway for carrying passengers.
- Grade, n**—The designation of the quality of a manufactured piece of wood.
- Grade, v**—To sort lumber and classify it according to quality. Synonym: cull, inspect, survey.
- Grader**—One who inspects and classifies lumber according to defects present. Synonym: culler, scaler, inspector, marker.
- Grading rules**—Specifications by which lumber is grouped according to quality.
- Grain**—In wood, term used with reference to arrangement or direction of wood elements and to relative width of growth rings. To have specific meaning it must be qualified.
- Grapple**—A hinged mechanism capable of being opened and closed, used to grip logs in yarding and loading.
- Grapple yarding**—Cable yarding with grapples instead of chokers.
- Ground handling line**—One of a number of lines attached to a balloon for handling and bedding down.
- Ground lead**—A method of yarding logs in which the pull of the skidding line is parallel to the ground.
- Ground mitt**—A small sawmill placed directly upon the ground—unfloored.
- Guide blocks**—Arms of the saw-guide mechanism which hold the guide pins.
- Guide bracket**—Frame supporting the saw-guide pins.
- Guide pins**—Parts of the saw-guide mechanism which actually contact the saw.
- Guide plates**—Metal plates fixed to synchronize with the kerf at the rear of the saw.
- Guide rail**—A rail that guides the movement of the sawmill carriage.
- Guide (saw)**—A device for steadying a saw.
- Guides (dip-tank chains)**—Metal channels in which conveyor chains run.
- Gullet**—On a saw, the rounded cavity in which sawdust accumulates and is carried from the cut. Synonym: throat.
- Gum**—To grind out throat (gullet) of a saw.
- Gummer**—Tool used to cut out throats of saw. Synonym: chambering machine.
- Guy**—A rope, chain, or rod attached to something to brace, steady, or guide it.
- Hammer bench**—A wood bench as an extension of the anvil opposite the tensioner's position and supporting the rim of the saw when testing for tension; it contains a peg on a sliding panel for centering the saw when it is hammered.

- Handline**—A line managed by direct contact with the hands.
- Hardwoods**—The botanical group of trees that are broadleaved. The term has no reference to the actual hardness of the wood. Angio-sperms is the botanical name for hardwoods.
- Haulback block**—A block on the spar through which the haulback line runs.
- Haulback line**—A wire rope used to pull the main line back to the timber after each haulage in logging.
- Headblock**—That portion of a sawmill carriage on which the log rests. Each headblock consists of a base, a knee, a taper set, dogs, and a rack-and-pinion gear, or some similar device for advancing the knees toward or withdrawing them from the saw line.
- Head rig**—Sawing equipment used in the primary breakdown of logs.
- Headsaw**—Log-cutting saw in sawmill. Synonym: log saw.
- Head sawyer**—See Sawyer.
- Head spar**—A spar at the landing of a skyline logging operation.
- Head tree**—See Head par.
- Heel boom**—A loading boom against which the end of a log being loaded bears and is steadied as it is lifted and swung into position.
- Heel line**—A light line for tightening the heel tackle attached to a skyline.
- Heel tackle**—A system of lines and blocks used to tighten the skyline.
- Herringbone felling**—Timber felled in herringbone fashion to lead to the center of the skyline road.
- High-lead**—A cable logging system in which lead blocks are hung on a spar to provide lift to the front end of the logs.
- High-rigger**—A logger who tops trees and rigs them with guys, blocks, and lines.
- High-speed teeth**—Saw teeth made of an alloy steel which is heat-treated and retains much of its hardness and toughness at red heat, thus enabling tools made from it to cut at such speeds that they become red through friction.
- Holder (saw tooth)**—A device for locking inserted saw teeth in a circular saw.
- Hollow ground**—Having concave surfaces.
- Honeycomb**—Checks, often not visible at the surface, that occur in the interior of a piece, usually along the wood rays, or annual rings.
- Hook**—Angle between the face of a saw tooth and a line drawn from the extreme point of the tooth perpendicularly to the back of a bandsaw, or to the center of a circular saw.
- Hookaroon**—Curved pike, or pike and hook fitted to a handle from 36 to 38 inches long. Used in handling crossties, lumber, poles, posts, staves, timber, and like products. Synonym: pickaroon.
- Hopper**—A receptacle, usually funnel-shaped, with an opening at the lower part for delivering material.
- Horizontal resaw**—A band resaw that cuts in a horizontal line, as compared to a vertical band resaw, which cuts in a vertical line.
- Hot deck**—A pile of logs from which logs are hauled as soon as they are yarded.
- Hot landing**—See Hot deck.
- Hypsometer**—An apparatus for determining heights, as of trees.
- Infeed rolls**—Rolls placed ahead of certain types of saws to force the material through the saw.
- Inserted point**—The tooth used in an inserted-tooth saw.
- Inserted tooth**—See Bit.
- Inspect**—See Grade.
- Interlocking yarder**—Incorporates a means of coupling the main and haulback drums so as to maintain running-line tension.
- Intermediate support spar**—A spar (tree(s)) located between the headspar and tailspar to support a multispan skyline.
- Interior finish**—Dressed and often patterned lumber used for finishing the interior of buildings.
- Jack**—In lumber piling, to pass boards to piler on top of lumber stack.
- Jackladder**—An inclined plane with a trough up which logs are drawn into a sawmill.
- Jammer**—A lightweight, two-drum yarder, usually mounted on a truck with a spar and a boom, which may be used for both yarding and loading.
- Jointing**—The act of reducing points of all teeth in a circular saw to coincide with the circumference of a circle when the saw is rotated; it is accomplished by abrasion.
- Joist**—1. Piece of timber which is used to support floor of building. 2. Piece of lumber 8 feet or more in length, from 1-1/2 to 4-1/2 inches in thickness, and from 6 to 12 inches wide.
- Kerf**—The width of cut made by a saw.
- Key**—A small, parallel-sided piece, flat or tapered on top, for securing pulleys and other parts to shafts.
- Keyway**—A groove or channel for a key, as in a shaft or the hub of a pulley. A keyseat.
- Kilnig**—A short thick pole.
- Kiln**—A heated chamber for drying lumber.
- Kiln drying**—The process of drying wood in a kiln with the use of artificial heat.

- Knee**—The part of a sawmill carriage headblock that bears the carriage dogs, which hold the log being sawed. It also supports the levers used to operate both the carriage dogs and the taper set.
- Knot**—That portion of a branch or limb which has become incorporated in the body of a tree.
- Landing**—A place where logs are collected preparatory to further transportation by water or land.
- Lateral yarding**—Any movement of logs towards the center of a skyline road.
- Lead**—Adjustment of the saw so that the distance to the track rail is slightly less at the front than at the back edge of the saw. The front edge is that which first contacts the log. Also a block or series of blocks or rollers attached to a stationary object to guide the cable by which logs are dragged.
- Left-hand blower**—A blower in which, viewed when standing on the log deck and facing the rear of the mill, the fan-drive pulley is on the right and the intake on the left side of the housing.
- Left-hand sawmill**—Sawmill in which, when standing on log deck and facing rear of mill, carriage and saw are on left hand. *See* Right-hand sawmill.
- Leveling**—Act of bringing a saw to a flat, even surface.
- Lever-type swage**—Device for widening the tips of saw teeth by drawing out the tooth point between a lever-actuated die and a fixed anvil.
- Live rollers**—Power-driven rollers used in sawmill to transport timbers, boards, and slabs.
- Loaded deflection**—The vertical distance between the chord and skyline, measured at midspan, when the skyline is supporting a load of logs.
- Loader**—At sawmill plant, one who loads lumber on car.
- Loading boom**—A structural member used to raise and position logs during loading.
- Lodging**—The action of a tree in felling, when it hangs up in an adjacent tree rather than falling free to the ground.
- Log-beam mill**—The type of mill employing a sawmill carriage on which the knees, dogs, and sometimes the setwork, are fixed to a movable beam extending lengthwise of the carriage frame, and advanced or receded by a setwork mechanism.
- Log deck**—1. Platform in sawmill upon which logs are collected and stored previous to placing them on carriage for sawing. Synonym: deck, mill deck. 2. *See* Rollway.
- Log dog**—A metal bracket attached at intervals to the log-haul chain to prevent slippage in logs being transported from log pond or yard level to mill deck.
- Logging**—The operations of felling trees, cutting them into logs, and transporting them to the sawmill.
- Log roller**—At portable sawmill plant, one who assists sawyer in placing logs on carriage. Synonym: juggler, turner.
- Log rule**—A table showing the estimated number of board feet of lumber that can be sawed from logs of various lengths and diameters.
- Log scale**—The board-foot content of logs as determined by a log rule.
- Log turner**—A device, usually attached to beams over the log deck, consisting of a drum driven by friction gearing, on which is wound a chain or cable; used in turning logs on a sawmill carriage. A device actuated by a steam piston and consisting of two or more arms or skids and a hook, which are used to shove or turn logs on a sawmill carriage. Its movements are controlled by the sawyer.
- Loose collar**—The flanged collar that is fixed against the circular saw by attachment to the arbor by means of a nut.
- Loose knot**—Knot not held firmly in place.
- Lug**—A projection, as on a chain, by which anything is supported or carried.
- Lug pin**—A metal pin chambered in the fixed and loose collars and passing through a pin hole in the saw to prevent the saw from slipping on the shaft.
- Lumber**—The product of the saw and planing mill not further manufactured other than by sawing, resawing, and passing lengthwise through a standard planing machine, crosscut to length and worked.
- Lumber buggy**—Two-wheeled truck for transporting lumber around a sawmill plant and yards. Synonym: buggy, dolly, lumber truck.
- Lumber jack**—Stand or tripod, usually tipped at peak with a spike, which is used as fulcrum in jacking lumber to top of lumber pile.
- Lumber scale rule**—A rule indicating the number of square feet contained in boards of various widths and lengths.
- Magnetic brake**—A friction brake controlled by means of a solenoid.
- Main alley**—A lumberyard alley on which lumber piles front.
- Main line**—The hauling cable.
- Main line block**—A block on a spar through which the main lines run.

Mandrel—See Arbor axle.

Marker—At portable sawmill plant, one who takes lumber from behind saw, scales, marks, and tallies it. Synonym: scaler, surveyor.

Marlin spike—An iron tool that tapers to a point and is used to separate strands of rope.

Matched lumber—Lumber that is edge-dressed and shaped (worked) to make a close tongue-and-groove joint at the edges or ends when laid edge to edge or end to end.

Mensuration—Act, process, or art of measuring.

Merchantable lumber—As applied to output of sawmill, entire cut of the mill, except mill culls.

Mill run—As generally understood, all of lumber output of sawmill which has sale value.

Millwork—Generally all building materials made of finished wood and manufactured in millwork plants and planing mills, excluding flooring, ceiling, and siding.

Millwright—Skilled mechanic who keeps sawmill in repair.

Mine detector—An electrical device for detecting the presence of metal.

Miscut—Lumber having greater variation in thickness, except as to wane, between any two points than provided for in copyrighted editions of grading rules.

Mobile spar—See Portable spar.

Moisture content of wood—Weight of the water contained in the wood; usually expressed in percentage of the weight of the oven-dry wood.

Multispan skyline—A skyline having one or more intermediate supports.

Nominal size—As applied to timber or lumber, the roughsawn commercial size by which it is known and sold in the market. See Lumber; Dressed size.

Odd lengths—Term applied to lumber the length of which is odd feet.

Offbearer—One who stands directly behind head-saw in mill and seizes slabs and boards as they come from the saw, placing them flat on live rollers. Synonym: offbear, saw tailer, swamper, tail sawyer, take-away man, slab stripper.

Offset (knee)—See Taper bar.

Offsetting the carriage—The shunting of the carriage frame away from the sawline when the carriage is giggered back by a device attached to a sawmill carriage frame and also to one or more axles of the carriage trucks.

Oil motor—A rotary engine actuated by the reaction, under pressurized oil, of radial pistons on a shaft eccentric to a containing ring. Speed and torque are increased or decreased by the controlled operation of valves which let oil

under pressure into the pistons in a predetermined cycle.

Opening line—A line used to open a grapple.

Open-side carriage—A skyline carriage that opens on one side to enable it to pass immediate support jacks.

Output—See Cut.

Overhang—Difference between mill cut of merchantable lumber and log scale. Usually calculated as percentage of 1,000 feet log scale.

Overlap—In a belt splice, the part extending over another part.

Overwound cable—Line reeled on or paid off the top of a drum.

Pass block—A light block hung at the top of the spar tree and used to haul up the bull block and other gear in rigging the tree.

Pass line—A light cable used to haul gear or other rigging up the spar tree.

Patterned—Following a mechanical design.

Pawl—A pivoted tongue or sliding bolt on one part of a machine adapted to fall into notches or interdental spaces (between teeth) on another part.

Peavy—A stout lever from 5 to 7 feet long, fitted at the larger end with a metal socket and spike and a curved steel hook that is pivoted on a bolt. Differs from a cant hook in having a spike instead of a toe ring and lip at the end.

Pickaroon—See Hookaroon.

Piling strip—See Sticker.

Pinion wheel—A gear with teeth designed to mesh with those of a larger wheel or with a rack.

Pin knot—Knot not more than 1/2 inch in diameter.

Pitch—Angle between back of tooth and line drawn from extreme point of tooth to back of bandsaw or to center of circular saw.

Pitch diameter—In belt measurements, the diameter at the outside of the belt minus the belt thickness.

Pitch pocket—In coniferous wood, opening between annual growth rings containing pitch.

Pitch seam—Shake or check which is filled with pitch.

Pitch streak—In coniferous woods, well-defined accumulation of pitch at one point.

Pitman—A connecting rod.

Plain sawed—All lumber which is not quarter-sawed. Lumber sawed parallel with the pitch of the long and approximately tangent to the growth rings; that is, the rings form an angle of less than 45° with the surface of the piece.

- Planetary gears**—A train of spur or bevel gears in which one or more move around the circumference of another which may be fixed or movable.
- Plank**—1. Piece of lumber from 2 to 3 inches thick. 2. In southern yellow pine export trade, pieces 7 inches and up in width and from 2 to 2¾ inches in thickness. 3. Piece of lumber 8 feet or more in length, more than 11 inches in width, and from 1½ to 4½ inches in thickness. A broad board, usually more than 1 inch thick, laid with its wide dimension horizontal and used as a bearing surface.
- Pond slip**—The extension of a millpond to allow floating of logs to a point opposite the mill dock.
- Poor face**—That surface of the board containing the lesser area in clear cuttings.
- Portable sawmill**—Small sawmill which can be readily moved from one place to another. Usually daily capacity varies from 3 to 10 Mfbm (thousand foot board measure).
- Portable spar**—A collapsible tower used in high lead and skyline logging.
- Press roll**—Roller which holds lumber against feet roll when lumber is being fed into machine.
- Prime mover**—The initial source of motive power, the object of which is to receive and modify force and motion as supplied from some natural source, and apply them to drive other machinery.
- Pulley**—A small wheel with a grooved rim through which a rope runs.
- Rack**—A bar with teeth on one face for gearing with those of a pinion.
- Rack and pinion**—A form of carriage drive used in portable sawmills. A rack is attached to the underside of one of the beams of the carriage frame, and into it meshes a pinion wheel driven from a shaft on the saw husk.
- Raising lines**—The cable used to upend a portable spar.
- Random width**—All widths of lumber haphazardly mixed.
- Ratchet setter**—See Block setter.
- Receder**—A device on sawmill carriage for receding the knees away from the saw line. It may comprise either a coiled spring properly adjusted on set shaft, or a system of gears and friction pulleys by means of which set shaft can be revolved.
- Red heart**—See Firm red heart.
- Refuse**—That portion of tree which cannot be removed profitably from forest or utilized profitably at manufacturing plant or in a military operation.
- Refuse conveyor**—An endless chain traveling in a trough which transports sawmill refuse.
- Resaw**—A machine to cut boards, planks, slabs, or other material lengthwise into two or more pieces of equal length and width.
- Rick**—A pile of cordwood, stave bolts, or other material evenly ranked. The ends are usually held in place by stakes or by stacking against a tree.
- Rider**—A pulley placed to bring pressure on a belt in order to increase its effectiveness.
- Rigging**—The cable, blocks, and other equipment used in yarding logs.
- Right-hand sawmill**—A sawmill in which, when standing on log deck and facing rear of mill, carriage and saw are on right hand.
- Rip**—To cut a board lengthwise, parallel to the fibers.
- Rip tooth**—The type of saw tooth adapted for cutting parallel to the fibers of wood.
- Roller**—A cylindrical body movable about its longitudinal axis. One of a series of mounted cylinders used in moving lumber from the front to the tail end of a mill.
- Rollway**—Platform at mill upon which logs are unloaded from log cars. It may be built around edge of pond or along bank of stream to aid in dumping logs into water, or it may be so built that it is used as place for land storage of logs. Synonym: log deck, log dump.
- Rope drive**—A carriage feed system employing a rope or wire cable to propel the carriage when a drum, about which the cable is looped, is revolved.
- Rosser**—An attachment to plane a flat surface on a log.
- Rot**—See Decay.
- Rough lumber**—Lumber as it comes from the saw.
- Round-faced hammer**—A type of hammer used to flatten the surface and put tension in circular saws. It has a circular face with a convex plane, the curvature conforming to a radius of 4½ inches.
- Running**—See Cut.
- Running board**—The board of the hammer bench extending back from the anvil, which partially supports the saw.
- Running guy**—A line attached to the end of a loading boom on a jammer and used to swing the beam back and forth.
- Running line**—A movable cable.
- Running skyline**—A system of two or more suspended moving lines, generally referred to as main and haulback, that when properly ten-

- sioned will provide lift and travel to the load carrier.
- Safety guy**—A line rigged under the bull block to carry it down to the ground if the holding straps should fail.
- Safety strap**—A strap fastened to the bull block and around the guy for safety.
- Sap**—All the fluids in a tree, such special secretions and excretions as gum excepted.
- Sap stain**—Stain on sapwood of logs and lumber caused by fungi.
- Sapwood**—The layers of wood next to the bark, usually lighter in color than the heartwood and totaling $\frac{1}{2}$ to 3 inches in width, that are actively involved in the life processes of the tree.
- Saw alive, to**—To make all cuts on log parallel. Synonym: to saw through and through.
- Saw arbor**—Shaft and bearings on which circular saw is mounted.
- Synonym**—Arbor, mandrel.
- Saw around**—In sawing, to cut from three or more faces of log, the latter being turned in order to get best quality of lumber.
- Saw bill**—Instructions given to sawyer for sawing lumber of various kinds and sizes from given logs.
- Saw guide**—Device for steadying a saw.
- Saw kerf**—Width of cut made by a saw.
- Sawmill**—Plant at which logs are sawed into usable products. It includes buildings and grounds on which it is located.
- Saw timber**—Logs suitable in size and length for production of merchantable lumber.
- Sawyer**—One who controls carriage and other machinery used in sawing logs into lumber. Quality and quantity of lumber sawed depends on his judgment, skill, and speed.
- Scaler**—See Grader; Marker.
- Seasoning**—Removing moisture from green wood in order to improve its serviceability.
- Set beam**—Shaft on sawmill carriage, directly connected with setworks bearing pinions, one of which meshes into rack in each headblock and moves knees forward and backward as desired.
- Setter**—See Block setter.
- Setting**—The area logged to one yarder position. Temporary station of portable sawmill. Synonym: portable mill setting, setup.
- Set wheel**—The wheel of the setworks attached to the set-shaft, which, when turned with a lever, causes the knees to advance.
- Setworks**—Mechanism on sawmill carriage by means of which block setter advances knees and log toward saw line after a piece has been cut from log.
- Setworks scale**—Disk on saw carriage which shows distance in inches between saw line and face of knees. Synonym: dial, gage.
- Shackle**—A clevis.
- Shake**—A separation along the grain, the greater part of which occurs between the rings of annual growth.
- Shank**—A device for locking inserted teeth in a circular saw.
- Shaper**—An implement, consisting of dies and levers, which is used to compress saw teeth to a prescribed pattern.
- Shayswivel**—A fitting used to attach the slack-pulling line to the main line on a skyline system.
- Sheathing**—The structural covering, usually of boards or wallboards, placed over exterior studs or rafters of a structure.
- Sheave**—The grooved wheel of a pulley.
- Shim (bearings)**—A thin piece or slip of metal, wood, or other material used to fill in, as in leveling.
- Shiplapped lumber**—Lumber that is edge-dressed to make a close rabbeted or lapped joint.
- Shipping-dry lumber**—Lumber that has been partially dried to reduce weight and freight costs, but may still have a moisture content of 30 percent or more.
- Shorts**—Lumber shorter than standard lengths.
- Shotgun feed**—A long cylinder with a piston attached to the rear end of the sawmill carriage to draw the carriage back and forth.
- Shoulder**—An abrupt projection that forms an abutment on an object or limits motion.
- Side**—A logging unit.
- Side blocking**—A method of laterally displacing a slack line or skyline fall block to facilitate log hookup.
- Side dressing**—The act of adjusting all saw teeth on a saw to project laterally the same distance from the plate. It is accomplished by filing.
- Side gage**—A measuring device to indicate the amount of lateral projection of saw teeth beyond the surface of the saw.
- Siding**—Material manufactured for the specific function of serving as outside covering for buildings.
- Sills**—The horizontal timbers supporting the husk of a sawmill.
- Single-acting lever**—A device on the carriage of a sawmill which feeds the timber to be sawed transversely at the thrust or the return stroke of the lever, but not at both strokes, as in the double-acting lever.

- Single piston**—A lever of a setwork that causes knee movement only on the pull or backward thrust, as contrasted with the double-acting type, which causes movement on both forward and backward lever thrusts.
- Single-span skyline**—A skyline without intermediate support spars.
- Skid**—A timber bar or rail used in sets fastened to the bottom of a machine or structure that is to be slid on the ground.
- Skidding**—Process of conveying logs to a landing.
- Skidding line**—A cable to which chokers are attached for yarding logs.
- Skyline**—A cableway stretched tautly between two spars and used as a track for log carriers.
- Skyline carriage**—A wheeled device which rides back and forth on the skyline for yarding or loading.
- Skyline-crane**—A yarding system that is capable of moving logs laterally to a skyline as well as transporting logs either up or down a skyline to a landing.
- Skyline-crane carriage**—A skyline carriage that incorporates provisions for pulling slack in the skidding line.
- Skyline jack**—A device which supports the skyline at an intermediate point.
- Skyline logging**—A logging method in which a block or carriage rides on a skyline.
- Skyline road**—The area that is bounded by the length and lateral yarding width of any given skyline setting.
- Skyline road profile**—The ground profile under a skyline.
- Skyline slope**—The slant or inclination of the skyline chord, generally expressed as a percent.
- Slab**—The exterior portion of a log that is removed to get a flat face for sawing lumber.
- Slab-pile**—Place where slabs and other mill waste is burned or dumped.
- Slackline system**—A live skyline system employing a carriage, main line, and haulback line. The main and haulback lines attach directly to the carriage. The skyline is lowered by a slackening of the line to permit the chokers to be attached to the carriage. Lateral movement is provided by side blocking.
- Slack-pulling line**—A line used to pull out the main or tong line through a logging carriage.
- Slash**—The debris left after logging.
- Slash saw**—A device consisting of several circular saws mounted on a shaft at intervals varying from 16 to 48 inches and used to cut slabs, edgings, and other wood refuse into lengths suitable for laths and pulpwood, or for transporting to the refuse burner.
- Sliding hook**—A hook reeved on the skidding line to carry additional chokers.
- Snatch block**—A block that can be opened on one side to receive the bight of a rope.
- Snubbing line**—A line used for lowering a load.
- Softwoods**—The botanical group of trees that have needle or scale-like leaves and are evergreen for the most part, with bald cypress, western larch, and tamarack being exceptions. The term has no reference to the actual hardness of the wood. Softwoods are often referred to as conifers, and botanically they are called gymnosperms.
- Solid-tooth saw**—A saw having the teeth cut into edge.
- Sorted-length piling**—The practice of placing material of a single length or of a definite series of lengths in a single pile.
- Sound cutting**—A hardwood cutting free from rot, pitch, shake, and wane but permitted to contain sound knots and other items listed as defects and excluded from clear-face cutting.
- Sound defect**—Any defect allowed in sound cuttings, such as sound knots, sound bird pecks, stain, streaks or their equivalent, season checks not materially impairing the strength, and wormholes.
- Sound knot**—Knot which is solid across its face, is as hard as surrounding wood, and shows no indication of decay.
- Spar**—The tree or mast on which rigging is hung for one of the many cable hauling systems.
- Speed reducer**—An apparatus for reducing speed.
- Spiked roller**—Rollers either round or concave, which are armed with spikes and designed to feed logs or slabs against a saw. The rollers are usually power driven. Synonym: spiked rolls.
- Spiral grain**—See Cross grain.
- Split**—A lengthwise separation of the wood, due to tearing apart of the wood cells.
- Splitter-resaw**—A combination of sawmill equipment consisting of a circular saw fixed in a trough to rip into halves logs carried by conveyor chains, and a horizontal bandsaw to reduce these half logs to merchantable products.
- Spreader**—A thin disk or scythelike blade fixed behind a circular headsaw to guard against boards and pieces contacting the rear edge of the saw.
- Spring set**—A method of setting saws whereby one tooth is sprung to the right and the next to the left. Crosscut saws are spring-set, as are very narrow bandsaws.

- Sprocket**—Wheel with teeth on its rim arranged to fit into the links of a chain.
- Square-faced hammer**—A type of hammer used to flatten the surface and put tension in circular saws. The face has a rectangular outline with convex plane, the curvature conforming to a radius of 9-1/2 inches.
- Stack**—See Stick.
- Stacker**—1. One who places lumber in piles. Synonym: lumber piler, lumber stacker, piler. 2. Machine for stacking lumber on dry kiln trucks. Synonym: lumber piler, lumber stacker.
- Standard-band sawmill**—A mill containing a single-band saw and having a rated capacity of 50 Mfbm in 10 hours.
- Standard knot**—1. A knot that is sound and is between 3/4 inches and 1-1/2 inches in diameter. Synonym: tight knot, medium knot. 2. In hardwoods and cypress, a knot that is not more than 1-1/4 inches in diameter.
- Standard lengths**—Lengths into which rough lumber is cut for general use. The standard lengths in southern yellow pine are multiples of 2 feet, from 4 to 24 feet, inclusive. In surfaced products, such as flooring, ceiling, drop siding, and like material, the standard lengths range in multiples of 1 foot from 4 to 20 feet inclusive. Hardwood standard lengths run from 4 to 16 feet, inclusive.
- Standing line**—A fixed cable, not running during logging operations, for example, a skyline anchored at both ends.
- Standing skyline**—See Standing line.
- Stationary sawmill**—A sawmill which has permanent location, as contrasted with portable mill which may be moved at frequent intervals.
- Stick**—To place lumber in a pile with stickers separating each course of lumber.
- Sticker**—A piece of lumber that separates the different courses of lumber in a pile.
- Stock items**—Lumber in even widths from 3 to 12 inches.
- Stop shoe**—That part of the setting mechanism on a sawmill carriage which contacts the peg or backstop and shuts off further advance of the knees.
- Straight friction feed**—A feed-works mechanism entirely dependent upon friction contacts of moving parts to give motion to the sawmill carriage.
- Straight grain**—Wood of tree or log is said to be straight grained when principal wood cells are parallel to axis of growth. Piece of lumber is said to be straight grained when principal wood cells are parallel to its length.
- Strap**—A short cable with an eye in each end.
- Straw boss**—Subforeman in sawmill or sawmill yard.
- Straw drum**—A small drum on yarders; handles the straw line.
- Straw line**—A light cable used to string heavier lines.
- Strip**—See Stick.
- Strips**—Yard lumber less than 2 inches thick and less than 8 inches wide.
- Subflooring**—Boards placed between the joists and the finished flooring material.
- Surface**—The area of the sawed surface of a board, or, in the case of wane, the area of the portion of the board which contains wane.
- Surfaced framing**—Material for joists, rafters, studding, and similar framing items which has been planed.
- Surfaced stock**—A board, plank, timber, or other sawed material one or more sides of which are planed.
- Surface measure**—Area in square feet on one face of a board. When boards are 1 inch in thickness term is synonymous with board feet. Synonym: face measure, superficial foot.
- Swage**—A tool used to spread points of teeth of bandsaw or circular saw. Synonym: jumper, upset.
- Swage set**—To spread the ends of the teeth of a bandsaw or circular rip saw. A saw is swage set when the ends of the teeth are spread to a width greater than the thickness of the saw.
- Sweep**—A deviation in any direction from a straight line drawn from one end of a log to the other, excluding the deviation due to taper.
- Swell butted**—As applied to a log, enlarged at butt. Synonym: churm butted.
- Swing**—Moving logs to a landing from a distant deck to which they have been yarded.
- Swing saw**—A circular cutoff saw, frame of which is suspended on shaft either above or below cutting line. Saw is pulled forward to make cut and, when released, automatically retires from saw cut.
- Swing tree**—A spar tree to which logs are yarded either with or without cold decking, and swung to the landing.
- Swing-up saw**—A circular cutoff saw, frame of which is hung on shafts below cutting line. Saw is swung up out of its housing when in use. Chiefly used to cut large timbers.
- Swivel**—A part that pivots freely.
- Tagline**—A short piece of line added to anything, usually to a main line. A line used to position a loading grapple.

- Tailblock**—A block used to guide the haulback line at the back corner of the yarding area.
- Tailhold**—The anchorage at the outer end of a skyline, away from the landing. A line securing a tailblock to a stump.
- Tail sawyer**—See Offbearer.
- Tailspar**—A spar at the outer end of the skyline logging operation, away from the landing.
- Tailtree**—See Tailspar.
- Tally**—A record of the number of pieces and grades of lumber in a pile.
- Tallyman**—One who records on tally sheet the number and grade of pieces of lumber as they leave sawmill.
- Tally sheet**—A card or sheet of paper on which is recorded number of pieces and grades of lumber. Synonym: tally card.
- Tallystick**—See Lumber scale rule.
- Tandem rigs in multiple lines**—Several lines of machines, each line having at least two machines, one placed behind the other.
- Taper bar**—A lever attached to the knee of a sawmill carriage headblock, by means of which any knee may be placed out of alinement. It is of service when making the first cuts on swell-butted logs. Synonym: taper set lever.
- Taper block**—See Taper bar.
- Telescoping line**—A line or lines used to position and hold the upper section of a telescoping boom (portable spar) in place.
- Tension**—To make a circular saw or bandsaw more loose in the center than on the cutting edge.
- Tension gage**—Similar to a straightedge but having a convex edge, the curvature of which exactly coincides with the concave curvature of a properly tensioned saw, used when making the test for tension.
- Tether line**—Any line used to restrain a balloon in flight, such as the line from a logging balloon to the butt rigging.
- Thimble**—A ring of thin metal formed with a grooved outer edge so as to fit within an eye splice and protect the rope from chafing.
- Thread**—To reeve a line through logging blocks.
- Throat**—See Gullet.
- Tie or timber mill**—A sawmill that specializes in ties or heavy timbers.
- Tier**—One of two or more vertical rows, one beside the other, as of boards in a pile.
- Tight line**—A line held tight by braking or interlocking the receding line.
- Tightlining**—A method of high-lead logging in which the logs or butt rigging is lifted over obstructions by tightening the receding line.
- Timber**—Sawed material 5 inches or larger in least dimension.
- Timber cruise**—See Cruise.
- Timber cruiser**—See Cruiser.
- Timber cruiser's stick**—See Cruiser's stick.
- Tongline**—The loading line on a log loader. The skidding line from the carriage.
- Top face**—The back of the tooth, that part extending back from the point along the continuation of the line forming the gullet to the preceding tooth.
- Top guy**—One of several lines tied to the top of a spar tree.
- Top roll**—A roll so placed as to press down the top of the log and be automatically adjustable to log irregularities.
- Top saw**—Upper of two circular saws on head-saw, both hung on the same husk. Circular mills frequently do not have a top saw. Synonym: overhead saw.
- Tram**—A boxlike wagon running on a tramway.
- Tree jack**—A Y-shaped member used for skyline support at intermediate spars.
- Tree plate**—A steel plate with a hook at the bottom, spiked to a spar tree to prevent cutting of the wood by cables at the point where guy lines and straps are hung.
- Tree shoe**—A grooved member used for skyline support at the headspar or tailspar.
- Trial mandrel**—A shaft, collars, nut, bearings, and frame to support a circular saw when checking the condition.
- Trim**—To make square the ends of boards and timbers. Synonym: butt, clip, and equalize.
- Triple drum**—A three-drum yarder.
- Trolley**—Small iron-wheeled car running on wooden track; hauls lumber from portable sawmill to storage yard. Synonym: buggy.
- Turbine**—A rotary engine actuated by the reaction or impulse, or both, of a current of fluid subject to pressure.
- Turn**—The logs yarded in any one trip.
- Turning**—Turning the log about on its longitudinal axis.
- Twin circular**—A mill that has both a right-hand and a left-hand saw; used to slab logs or to rip cants. Both saws may be so mounted as to permit altering the distance between them.
- Twists**—Ridged projections on the surface of a circular saw.
- Undercut**—A notch made in a standing tree to guide the direction in which it will fall.
- Unit**—An area, equal to 12 square inches, used in determining the grade of hardwood lumber.

Universal joint—Any of various couplings or joints to permit swiveling or turning at any angle within defined limits.

Unloaded deflection—The vertical distance between the chord and the unloaded skyline, measured at midspan.

Upset swage—A tool used to spread the points of the teeth of a bank or circular rip saw.

Wane—Bark or lack of bark, or decrease in wood from any cause on edges of board, plank, or timber.

Warp—Any variation from a true or plane surface.

Washboard—The term used to denote action of saw or planing machine head which makes ridges on lumber.

Waste—That residual portion of log which, though not utilized at once, has a merchantable value. For example, sawdust and refuse used for fuel; those portions of logs, slabs, edgings, and trimmings used for laths, shingles, cooper-

age, and other products. As such, "waste" does not here have its literal meaning. Waste also means "leavings" which are of no use whatsoever.

Wet mill—A sawmill where logs are stored in water.

Winch—A mechanism having one or more barrels on which to coil a line for hauling or hoisting.

Yarder—A system of power-operated winches used to haul logs from their stumps to a landing.

Yard logs—The process of moving logs from mill yard to sawmill.

Yard lumber—1. Lumber which has been air-dried in a yard; often applied collectively to those grades of lumber usually air-dried. 2. Lumber that is manufactured and classified into those sizes, shapes, and qualities required for ordinary construction and general-purpose uses. 3. Lumber that is less than 5 inches thick and less than 8 inches wide.

INDEX

	Paragraph	Page		Paragraph	Page
Abney level	2-3b, c, 4-2c(3)	2-1, 4-2	Clearing working space	5-5	5-3
Aerial photos	4-2c(2)	4-2	Cold weather operation	9-25	9-14
Air compressor	3-4e	3-2	Common causes of faulty sizing ..	9-15	9-10
Air-drying lumber	11-4, 11-6	11-2, 11-3	Cone frustum	6-23b	6-15
Alinement of saw and teeth	10-5	10-9	Cordwood	6-8f	6-7
Arch skidding	3-4a	3-2	Crane	7-9b, 7-19	7-15, 7-23
Ax handling	6-2b	6-1	Crawler tractor	3-4a, 7-2, 7-4, 7-9c	3-2, 7-1, 7-3, 7-15
Backcut	5-9	5-5	Crook	6-21	6-14
Balloon logging	7-24	7-26	Crosscut saw crew	5-2b	5-1
Bicycle rig	7-7b	7-5	Crotch	6-22, 7-9b	6-15, 7-15
Billets	6-8a	6-6	Crotch grabs	7-4, 7-4b(1)	7-3, 7-4
Biltmore stick	2-4b, 2-6b	2-6, 2-8	Cruising	2-1-14	2-1-2-19
Bolt	6-8a	6-6	Decimal C log rule	6-9d, 6-10, 6-11	6-8, 6-11
Boom, McLean	7-8b(3)	7-12	Defects:		
Box piling	11-7	11-4	Broken-down sapwood	6-19	6-14
Broken-down sapwood	6-19	6-14	Circular rot	6-13b	6-11
Bucking:			Common	6-12	6-11
Chute	6-7	6-6	Cracks	9-10e, f	9-7
Plan	6-6	6-5	Crook	6-21	6-14
Procedures	6-6	6-5	Crotch	6-22	6-15
Operation	6-1, 6-3	6-1	Deductions	6-11, 9-10i	6-9, 9-8
Safety	6-6h	6-6	Fire scar	6-17	6-13
Butt rigging	7-7c(2)	7-9	Frost check	6-18	6-14
Cable logging	7-7	7-5	Heart check	6-16	6-13
Calipers, tree	2-6a	2-7	Log	6-11	6-9
Cant hook	7-8b	7-11	Punky sapwood	6-19	6-14
Carriage:			Ring shake	6-14, 9-10g	6-12, 9-7
Grapple	7-15, 7-18	7-21, 7-23	Rot	6-13, 6-15, 9-10g	6-11, 6-13, 9-7
Headblock type	8-5b	8-2	Spider heart	9-10g	9-7
Log-beam type	8-5a	8-2	Standard rule	6-11c	6-10
Parts	8-5	8-1	Sweep	6-21	6-14
Radio controlled	7-18b	7-23	Wind checks	6-20	6-14
Chain saw:			Wormholes	9-10h	9-8
Crew	5-2a	5-1	Diameter breast high (dbh)	2-5a	2-7
Sharpener	3-4d	3-2	Diameter measure	2-5	2-7
Use	3-4c	3-2	Direction of tree fall	5-4, 5-8, 5-11	5-1, 5-4, 5-7
Choker:			Dogs:		
Cable	7-1	7-1	Board	9-15a, b	9-10
Drawbar hook	7-3a(3)	7-2	Boss	8-8d	8-9
Hooks	7-3a(2)	7-2	Fixed post	8-8a	8-6
Chute	6-7, 7-1, 7-12, 7-12a	6-6, 7-1, 7-17	Hammer	8-8c	8-9
Circular rot	6-13b	6-11	Sliding	8-8b	8-8
Civilian sawmills:			Double-decked skidway	7-8b(1)	7-11
Faculty equipment	9-23b	9-14			
Maintenance	9-21	9-13			
Operation	9-20	9-13			
Rehabilitation	9-22	9-13			
Safety	9-23a	9-14			

	Paragraph	Page		Paragraph	Page
Ecology	7-16c	7-22	Floating logs	7-1	7-1
Edger:			Flume	7-1, 7-12,	7-1, 7-17,
Edging	8-13,	8-13,	Foreman, logging	7-12b	7-19
	9-11	9-8	Forest:	3-3a	3-1
Multiple-saw	8-13b	8-14	Estimates	2-1, 2-9,	2-1, 2-11,
Operator	9-2a (6), (7)	9-1		2-10, 2-12	2-16
Single-saw	8-13a	8-14	Stands	2-12c(1)	2-17
Vertical-saw	8-13c	8-14	Team	3-1	3-1
Edging procedure	9-11	9-8	Types	2-12c(2)	2-17
Electric feed	8-6f	8-4	Frost check	6-18	6-14
End racking	11-13	11-7	Gear and clutch feed	8-6e	8-3
Engineer forestry team:			Grabs	7-4,	7-3, 7-4
Basis of allocation	3-1b	3-1		7-4b(3)	
Capability	3-1a	3-1	Grab skipper	7-4b(1)	7-4
TOE	3-1a	3-1	Grading:		
Engineer unit sawmill operation	9-20	9-13	Logs	6-4	6-2
Equipment:			Lumber	9-8b,	9-4, 9-11
Mechanical	6-7, 7-9,	6-6, 7-15,		9-16b	
	7-11c(3)	7-17	Table	6-4	6-2
Skyline	7-7b, c, d	7-5-7-9	Grading log table	6-4	6-2
Use of	6-7	6-6	Grapple:		
Estimate, partial	2-12,	2-16,	Advantages	7-16	7-21
	2-13, 2-14	2-17, 2-9	Attachment	7-21	7-25
Estimating:			Carriage	7-15,	7-21,
Diameter	2-5, 2-6	2-7		7-18	7-23
Height	2-3, 2-4	2-1, 2-3	Crane	7-19	7-23
Volume of timber	2-10	2-16	Deflection	7-17b	7-23
Volume table	2-8	2-11	Ecology	7-16c	7-22
Without volume table	2-9	2-11	Fork	7-21	7-25
With volume table	2-8d	2-11	Log sorting	7-16b	7-22
Faulty sizing	9-15	9-10	Night operations	7-22	7-25
Faustman hypsometer	2-4a	2-3	Operation	7-17a	7-23
Feedworks:			Planning	7-17	7-22
Belts and pulleys	8-6c	8-3	Rigging	7-15	7-21
Belts, pulleys, and clutch	8-6d	8-3	Skidding	7-16b	7-22
Electric feeds	8-6f	8-4	Skyline	7-15, 7-16	7-21
Friction with belts and pulleys	8-6b	8-2	Truck mounted	7-20	7-25
Gear and clutch	8-6e	8-3	Use	7-9b,	7-15,
Hydraulic feeds	8-6g	8-4		7-15	7-21
Operating features	8-7	8-4	Yarding	7-15, 7-16a	7-21
Single-cylinder steam piston	8-6h	8-4	Gravity chute	7-12a(2)	7-19
Steam piston feeds	8-6h	8-4	Ground skidding	3-4a(1),	3-2, 7-3,
Straight friction	8-6a	8-2		7-4, 7-4a,	7-4
Two-cylinder steam feed	8-6h	8-4		7-4c	
Felling:			Handling logs	7-1, 7-16	7-1, 7-21
Backcut	5-9	5-5	Hauling logs	3-3	3-1
Crew duties	5-2	5-1	Headsaw:		
Cut	5-10b	5-6	Circular	8-2a	8-1
Direction	5-4	5-1	Guides	8-3	8-1
Larger trees	5-10c	5-6	Sash-gang	8-2b	8-1
Layout	5-3	5-1	Heart check	6-16	6-13
Leaning trees	5-11	5-7	Height measure	2-3	2-1
Lodged trees	5-13	5-9	Helicopter logging:		
Patterns	5-3	5-1	Communication	7-25b	7-27
Rotten trees	5-12	5-8	Crew	7-25a	7-27
Safety	5-14	5-9	Ground crew	7-25a(2)	7-27
Small trees	5-11d	5-7	Load capacity	7-25c	7-27
With chain saw	5-10	5-6	Loading speed	7-25d	7-27
Filing circular saw	10-6,	10-10,	Proplash	7-25f	7-27
	10-7	10-13	Slings	7-25e	7-27
Fire prevention	5-15,	5-9, 9-12	High-lead system	7-7c	7-9
	9-18h(20),		Hookaroon	7-4b(1)	7-4
	(38)		Hooks	7-3a(2)	7-2
Wire scar	6-17	6-13			

	Paragraph	Page		Paragraph	Page
Husk	8-4a, 8-12	8-1, 8-13	Log—Continued		
Hydraulic feed	8-6g	8-4	Scaling	6-9, 6-10	6-7, 6-8
Hypsometer:			Skidding	7-1	7-1
Faustman	2-4a	2-3	Small	7-4b(4)	7-4
Merritt	2-4b	2-6	Transportation	7-1	7-1
Improvised diameter measuring instruments:			Trimming	6-5a	6-3
Biltmore stick	2-6b	2-8	Turners	8-11	8-13
Tree calipers	2-6a	2-7	Wet storage	7-11	7-16
Improvised height measuring instruments:			Winching	7-4d	7-4
Modified Faustman hypsometer	2-4a	2-3	Logging:		
Modified Merritt hypsometer	2-4b	2-6	Arch	3-4b, 7-6a, b	3-2, 7-5
International:			Balloon	7-24	7-26
Log scale	6-23	6-15	Cable	7-7	7-5
One-fourth-inch rule	6-23	6-15	Definition	3-2	3-1
Jackladder	7-11c(3)	7-17	Equipment	3-4	3-2
Layout of felling	5-3	5-1	Foreman	3-3a	3-1
Lightening	6-18c	6-14	Hauling crew	3-3, 3-3c	3-1
Limbing	6-1, 6-2	6-1	Helicopter	7-25	7-26
Loading:			Lumberjack	3-3b	3-1
Cold	7-8	7-11	Mechanical power	7-2	7-1
Cross-haul method	7-8b(2)	7-12	Operation	3-2, 3-4	3-1, 3-2
Crotchline	7-8b(3)	7-12	Process	3-2	3-1
Devices	7-8b(3)	7-12	Roads	4-1	4-1
Double-tong device	7-8b(3)	7-12	Safety	7-14	7-19
Forest products	7-8	7-11	Section	3-3	3-1
Hot	7-8	7-11	Skyline	7-7b	7-5
McLean boom	7-8b(3)	7-12	Under unusual conditions	7-13	7-19
Safety	7-14b	7-20	Winch	7-2c	7-1
Sawlogs	7-8b	7-11	Lumber:		
Short bolts	7-8a	7-11	Box piling	11-7	11-4
Tree-length logs	7-8c	7-13	Crib piling	11-6b, c, 11-14	11-3, 11-7
Log:			Deterioration	11-2	11-1
Billets	6-8a	6-6	Drying	11-4, 11-6	11-3
Bolts	6-8a	6-6	End piling	11-6b, c, 11-12	11-3, 11-6
Choker	7-1	7-1	End racking	11-6b, c, 11-13	11-3, 11-7
Chute	6-7, 7-1, 7-12	6-6, 7-1, 7-17	Flat piling	11-15	11-7
Classification	6-8	6-6	Grading	9-8b, 9-16	9-4, 9-11
Crossties	6-8d	6-7	Green	11-2	11-1
Cull	6-11d	6-11	Labeling	11-4d	11-3
Defects	6-12	6-11	Pile construction	11-6	11-3
Defects deductions	6-11, 6-23	6-9, 6-15	Pile foundations	11-5	11-3
Floatable species	7-10a	7-16	Pile roofs	11-11	11-6
Grades	6-4	6-2	Piling	11-1, 11-4, 11-5, 11-6, 11-7, 11-8, 11-9	11-1, 11-2, 11-3, 11-4, 11-5, 11-6
Grapple sorting	7-16b	7-22	Props	11-1, 11-3	11-1, 11-2
Handling facilities, wet	7-11c	7-17	Sap stain	11-6a	11-3
Heavy	7-4b	7-4	Seasoning	11-2	11-1
Lengths	6-5	6-3	Size standards	9-14	9-10
Light	7-4a	7-4	Sorting	11-1, 11-4	11-1, 11-2
Loading	7-1, 7-8	7-1, 7-11	Stickers	11-10	11-6
Marks	6-9b	6-7	Warp	11-6a, 11-15	11-3, 11-7
Measuring	6-5b	6-5	Lumberjack	3-3b	3-1
Measuring pole	6-5b	6-5			
Mining timbers	6-8e	6-7			
Movement by water	7-10, 7-10b, c	7-16			
Piling	6-8c	6-7			
Poles	6-8b	6-6			
Preloader	7-8d	7-13			
Rules	6-9d	6-8			

	Paragraph	Page		Paragraph	Page
Lumberyard:			Operation of trailer-mounted sawmill—Continued		
Air circulation -----	11-2b, 11-4, 11-6	11-1, 11-2, 11-3	Stopping -----	9-5d(2)	9-3
Hand stacking -----	11-2f, 11-6a	11-2, 11-3	Operation on uneven terrain -----	9-26	9-14
Layout -----	11-2	11-1	Parallel strip method estimate -----	2-14	2-19
Operation -----	11-4c	11-3	Partial estimates -----	2-12, 2-13, 2-14	2-16, 2-17, 2-19
Piling -----	11-1, 11-4, 11-5, 11-6, 11-7, 11-8, 11-9	11-1, 11-2, 11-3, 11-3, 11-4, 11-5, 11-6	Percentage reading method of tree height -----	2-3d	2-1
Road -----	11-2d	11-2	Pile roof -----	11-11	11-6
Safety -----	11-16	11-7	Piling:		
Temperature -----	11-2a, d	11-1, 11-2	Air drying -----	11-4	11-2
Mandrel -----	8-4b, 10-4c(3)	8-1, 10-7	Box -----	11-6a, 11-7	11-3, 11-4
McLean boom -----	7-8b(3)	7-12	Crib -----	11-6b, c, 11-14	11-3—11-7
Measurement of diameter:			Crossbeam -----	11-5b, 11-7	11-3, 11-4
Breast high -----	2-5a	2-7	End -----	11-6b, c, 11-12	11-3—11-6
Comparison of instruments -----	2-7	2-10	End racking -----	11-6b, c, 11-13	11-3—11-7
Diameter breast high (dbh) -----	2-5a	2-7	Flat -----	11-15	11-7
Improvised instruments -----	2-6	2-7	Foundations -----	11-5	11-3
Steel tape -----	2-5b	2-7	Sorted-length -----	11-8	11-5
Measurement of tree height:			Stickers -----	11-10, 11-12	11-6
Abney level -----	2-3b, c	2-1	Stringers -----	11-5b	11-3
Improvised instruments -----	2-4	2-3	Unit-package -----	11-9	11-6
Percentage reading method -----	2-3d	2-1	Poles -----	6-5b, 6-8b, 7-4a	6-5, 6-6, 7-4
Trigonometric method -----	2-3e	2-3	Portable sawmill -----	9-2a	9-1
Merritt hypsometer -----	2-4b	2-6	Powersaw fire prevention -----	5-15	5-9
Milling:			Preloaders -----	7-8d	7-13
Hardwood -----	9-10	9-7	Punky sapwood -----	6-19	6-14
Softwood -----	9-9	9-4	Relocation of sawmill -----	9-7	9-4
Mill operation -----	9-5	9-3	Rigging -----	7-3b, 7-7d, 7-8e, 7-15	7-3, 7-9, 7-13, 7-21
Mine timbers -----	6-8e	6-7	Right cylinder -----	6-11b	6-10
Montelius clevis -----	7-7c(4)	7-9	Ring shake -----	6-14	6-12
Moving sawmill -----	9-7	9-4	Ripsaw filing -----	10-6	10-10
Night operations -----	7-22, 9-27	7-25, 9-14	Road:		
Notching -----	5-7	5-3	Alinement -----	4-2c(6)	4-2
One-fourth inch rule -----	6-23	6-15	Bed -----	4-3a	4-3
Operation in cold weather:			Construction -----	4-3	4-3
Cold weather -----	9-25	9-14	Construction method -----	4-3b	4-3
Frozen timber -----	9-25a	9-14	Construction safety -----	4-4	4-5
Ice on equipment -----	9-25b	9-14	Curve -----	4-2c(6), 4-3d	4-2, 4-3
Operation in mud and water:			Erosion -----	4-1c, 4-3e	4-1, 4-4
Belts -----	9-24c	9-14	Grade -----	4-2d	4-2
Drainage -----	9-24b	9-14	In swampy area -----	4-2c(5)	4-2
Platform -----	9-24e	9-14	Layout -----	4-2c(7)	4-2
Pulleys -----	9-24c	9-14	Location -----	4-2c	4-2
Reinforcing foundation -----	9-24a	9-14	Logging -----	4-1	4-1
Ropes -----	9-24c	9-14	Maintenance -----	4-3f	4-5
Saws -----	9-24d	9-14	Military -----	4-2a	4-1
Walks -----	9-24e	9-14	Planning -----	4-2	4-1
Operation of semitrailer-mounted sawmill -----	9-6	9-3	Primary skid -----	4-1b	4-1
Operation of trailer-mounted sawmill:			Push-up -----	4-2c(5)	4-2
Controls -----	9-5a	9-3			
Log sizes -----	9-5b	9-3			
Maintenance -----	9-5c	9-3			
Starting -----	9-5d(1)	9-3			

	Paragraph	Page		Paragraph	Page
Road—Continued			Saw—Continued		
Reconnaissance	4-2c	4-2	Tension	10-4	10-5
Secondary skid	4-1c	4-1	Tooth holder	10-2b(5)	10-1
Skid	4-1b, c, 4-2	4-1	Trim	8-14,	8-14, 8-15
Switchbacks	4-3d	4-3		8-14c	
Topography	4-2c	4-2	Two-or-three-saw cutoff	8-14b	8-14
Trails	4-2c(7)	4-2	Use	10-3	10-1
Truck	4-1a	4-1	Sawing:		
Water bars	4-3e	4-4	Basic factors	9-8	9-4
Woods	4-1	4-1	Hardwood logs	9-10	9-7
Rot:			Oversized logs	9-13	9-9
Circular	6-13b	6-11	Procedures	9-8—	9-4—
Stump	6-13a	6-11		9-16	9-11
Safety:			Softwood logs	9-9	9-4
Brushing out	5-6	5-3	Sawmill:		
Bucking	6-6h	6-6	Carriage	8-5	8-1
Felling	5-2a, 5-3a,	5-1,	Crew	9-2	9-1
	5-10a, b, c,	5-6, 5-7,	Crew coordination	9-2c	9-1
	5-11		Crew duties	9-2	9-1
	5-13a, b, c,	5-9	Dogs	8-8	8-6
	5-14		Feedworks	8-6	8-2
Hooker	7-14c	7-20	Headblock	8-5b	8-2
Limbing	6-2	6-1	Log-beam	8-5a	8-2
Loading	7-14b	7-20	Military	8-15	8-15
Lumberyard	11-16	11-7	Operation	9-5	9-3
Powersaw	5-15	5-9	Operation by Engineer units	9-20	9-13
Road construction	4-4	4-5	Receders	8-9	8-9
Sawmill operation	9-18	9-11	Rolls	8-12	8-13
Saw operation	9-19	9-13	Safety	9-18	9-11
Skidding	7-14a	7-19	Semitrailer-mounted	8-17	8-15
Tong setting	7-14c	7-20	Setworks	8-9	8-9
Tractor	7-2a	7-1	Spreaders	8-12	8-13
Truck drivers	7-14d	7-20	Trailer-mounted	8-16	8-15
Wire ropes	7-14b	7-20	Yard crew	9-3	9-2
Woods	3-5	3-2	Scale book	6-9c	6-8
Sample plot method estimate	2-13	2-17	Scaling	6-1, 6-9,	6-1, 6-7,
Saw:				6-10	6-8
Alinement	10-5	10-9	Scribner decimal C log rule	2-9c,	2-11, 6-8,
Battery trimmer	8-14c	8-15		6-10, 6-11,	6-9,
Care	10-1	10-1		6-23	6-15
Chip thickness	10-3e	10-5	Setworks and receders:		
Circular crosscut	10-7	10-13	Indicators	8-10	8-12
Cutoff	8-14	8-14	Lever-operated	8-9a	8-9
Design	10-3c	10-3	Power-actuated	8-9c	8-11
Eliminating twist	10-4d(3)	10-7	Spring-actuated	8-9b	8-10
Filing	10-6	10-10	Sheaves	7-8e	7-13
Gullets	10-3c	10-3	Size standards:		
Hammering	10-4d(2),	10-7,	Lumber	9-14, 9-14b	9-10
	10-4e(1),	10-8	Ties	9-14	9-10
	10-4h		Timber	9-14	9-10
Leveling	10-4c(2),	10-7,	Sizing, faulty	9-15	9-10
	10-4e(3),	10-8	Skidding:		
	10-4g		Arch	3-4a(1)	3-2
Maintenance	10-1	10-1	Grapple	7-16b	7-22
Safety	9-19	9-13	Ground	3-4a(1),	3-2,
Selection	10-3	10-1		7-4, 7-4c,	7-3, 7-4.
Sharpening	10-6f, i,	10-12,		7-7a	7-5
	10-7	10-13	Pans	7-5b	7-5
Single cutoff	8-14a	8-14	Safety	7-14a	7-19
Spacing of teeth	10-3d	10-4	Sled	3-4a(1),	3-2, 7-5
Speed	10-3e	10-5		7-5a	
Teeth	10-2,	10-1, 10-3,			
	10-3c, d	10-4			

	Paragraph	Page		Paragraph	Page
Skidding—Continued			Timber—Continued		
Tongs -----	7-4, 7-4b(2)	7-3, 7-4	Size standards -----	9-14	9-10
Tractor arch -----	7-6	7-5	Stand -----	1-1b	1-1
Skid-mounted winch -----	7-8b(3)	7-12	Types -----	2-2	2-1
Skid road:			Timber cruising -----	2-1—14	2-1—2-19
Alinement -----	4-2c(6)	4-2	Trackways -----	8-5	8-1
Construction -----	4-3	4-3	Tractor:		
Construction economy -----	4-2b	4-1	Arch -----	7-6, 7-6b	7-5
Construction safety -----	4-4	4-5	Crawler -----	7-2	7-1
Curve -----	4-2c(6), 4-3d	4-2, 4-3	Traction -----	7-2b	7-1
Erosion -----	4-1c, 4-3e	4-1, 4-4	Trailer-mounted sawmill:		
Grade -----	4-2c(7), d	4-2	50-inch saw -----	9-4a	9-2
In swampy area -----	4-2c(5)	4-2	Bracing -----	9-4d	9-2
Layout -----	4-2c(7)	4-2	Conveyors, sawdust -----	9-4e	9-2
Location -----	4-2c	4-2	Feed rope -----	9-4f	9-2
Logging -----	4-1	4-1	Instructions -----	9-4	9-2
Planning -----	4-2	4-1	Leveling -----	9-4c	9-2
Primary -----	4-1b	4-1	Operation test -----	9-4h	9-3
Pushup -----	4-2c(5)	4-2	Power -----	9-4b	9-2
Reconnaissance -----	4-2c	4-2	Reeving -----	9-4f, g	9-2
Secondary -----	4-1c	4-1	Sawdust conveyor -----	9-4e	9-2
Slope -----	4-3b, c	4-3	Setting up -----	9-4b	9-2
Switchbacks -----	4-3d	4-3	Test, operation -----	9-4h	9-3
Topography -----	4-2c	4-2	Trailing chute -----	7-12a(1)	7-17
Water bar -----	4-3e	4-4	Transportation -----	7-1—	7-1—
Skyline:			7-13 -----		7-19
Automatic hook -----	7-7b(2)	7-5	Transportation by water -----	7-10, 7-10b, c	7-16
Block -----	7-7b(2)	7-5	Tree calipers -----	2-6a	2-7
Carriage -----	7-7b(2)	7-5	Tree height measurement -----	2-3	2-1
Haulback -----	7-7b(3)	7-9	Trigonometric method of measuring -----	2-3e	2-3
High-lead systems -----	7-7c	7-9	Trim and cutoff saw -----	8-14	8-14
Logging -----	7-7b	7-5	Trimming -----	6-5, 9-9s, 9-12	6-3, 9-7, 9-9
Tackle -----	7-7b(2)	7-5	Transportation of logs -----	7-1	7-1
Sleds and pans -----	7-5	7-5	Tree calipers -----	2-6a	2-7
Slip chains -----	7-4	7-3	Tree rot -----	5-12, 6-13, 6-15	5-8, 6-11, 6-13
Spreaders and rollers -----	8-12	8-13	Truck road -----	4-1a, 4-2d	4-1, 4-2
Steam piston feed -----	8-6h	8-4	Turners, log -----	8-11	8-13
Storage, wet -----	7-11	7-16	Undercut -----	5-7	5-3
Streams and rivers -----	7-10	7-16	Uneven terrain -----	9-26	9-14
Stump rot -----	6-13a	6-11	Unloading logs -----	7-9	7-15
Switchback -----	4-3d	4-3	Volume table -----	2-8	2-11
Tallying -----	9-16a	9-11	Wet storage -----	7-11	7-16
Team, forestry -----	3-1	3-1	Winch -----	7-2c, 7-4d, 7-7b(2), (3)	7-1, 7-4, 7-5, 7-9
Teeth (saw):			Wind checks -----	6-20	6-14
Inserted -----	10-2b(5)	10-1	Wire rope table -----	7-7b(5)	7-9
Interchangeability -----	10-2b(5)	10-1	Woods road -----	4-1	4-1
Spring-set -----	10-2a	10-1	Wormholes -----	6-17b	6-14
Swage-set -----	10-2b	10-1	Yard crew -----	9-3	9-2
Tensioning saw -----	10-4	10-5	Yarding:		
Ties size standards -----	9-14	9-10	Crane, grapple -----	7-19	7-23
Tight-lining system -----	7-7c(3)	7-9	Grapple -----	7-15, 7-16	7-21
Timber:			Night operations -----	7-22	7-25
Cruise -----	2-1	2-1	Section -----	9-1—9-3	9-1, 9-2
Cutting -----	1-1b	1-1			
Estimating -----	2-8, 2-14	2-11, 2-19			
Identification -----	2-2	2-1			
Measurement -----	2-3, 2-14	2-1, 2-19			
Mine -----	6-8e	6-7			
Removing -----	1-1b	1-1			

By Order of the Secretary of the Army:

BRUCE PALMER, JR.
General, U. S. Army
Acting Chief of Staff

Official:

VERNE L. BOWERS
Major General, United States Army
The Adjutant General

Distribution:

To be distributed in accordance with DA Form 12-21 (qty rqr block no. 164) requirements for Lumber, Millwork, Plywood and Veneer.

PX 001 675 657

3 6

PLEASE RETURN TO
ALDERMAN LIBRARY

DUE	DUE
4/27/90	
5/31/90	
7/6/91	

